

Stabilization of Injection-Locked Lasers Using Spatial Mode Interference

D. J. Ottaway, M. B. Gray, D. A. Shaddock, C. Hollitt, P. J. Veitch, J. Munch, *Member, IEEE*, and D. E. McClelland

Abstract—We report the use of spatial-mode-interference, or tilt-locking, for the active stabilization of injection-locking of a Nd:YAG laser. We show that this control scheme is robust and adds negligible frequency noise to the injection-locked laser.

Index Terms—Injection-locked oscillators, laser stability, Neodymium:YAG lasers.

I. INTRODUCTION

INJECTION-LOCKING of a slave laser by a lower-power single-frequency stable master laser is an excellent method of producing a higher power single-frequency stable laser [1]–[9]. However, the slave laser can be injection-locked only if the frequencies of the master and slave lasers differ by less than the injection-locking range [10], [11]. To provide long-term injection locking, a servo that controls this frequency difference is usually required.

The error signal required for the injection-locking servo system is often obtained using a technique that is very similar to the Pound–Drever–Hall (PDH) method for frequency stabilization of lasers [12]. In this technique, the frequency difference is determined by measuring the phase of the output of the slave laser relative to a phase reference, which consists of phase-modulation sidebands that are not resonant in the slave laser. The phase difference changes from $-\pi/2$ to $\pi/2$ as the frequency difference is swept across the locking range [10], [11]. The error signal is produced by detecting the heterodyne beat between the output of the slave laser and the sidebands using a low-noise high-bandwidth photodiode, and then demodulating to baseband using a double balanced mixer.

The PDH modulation frequency must be larger than the cold-cavity linewidth of the slave laser, and the master laser should be close to shot-noise-limited at this frequency for maximum signal-to-noise ratio (SNR). Since the slave laser should be compact to improve servo reliability, the former requirement often leads to a modulation frequency ~ 50 – 150 MHz, and the technique thus requires an electro-optic modulator (EOM). For injection-locked chain architectures, in which a medium power injection-locked laser is used to injection-lock a high power slave laser [9], [13], [14], the EOM must be able to transmit relatively large CW powers without introducing intensity or polarization modulation. Alternatively, the phase-modulation side-

bands could be imposed using a Mach–Zehnder interferometer that has a low-power EOM in one of its arms and uses a control system to minimize the power transmitted into one of the outputs of the recombination beamsplitter. This solution is more complicated, however, and restricts the modulation index of the sidebands.

An alternative technique for phase-locking lasers to high-finesse cavities and second-harmonic generators has recently been demonstrated [15]. In this technique, the phase reference is provided by a spatial mode that is not resonant in the cavity. This mode can be produced by tilting the input beam (see below) and thus the technique is referred to as tilt-locking (TL). It does not require a modulator and despite operating at baseband should have good signal-to-noise, due to potentially high common-mode-rejection of intensity noise. Since this technique requires fewer in-beam components, it is particularly suitable for high power laser applications, such as injection-locking. Further, the output of the injection-locked laser is free from parasitic modulation, which might be important for high precision metrology applications such as laser interferometric detection of gravitational waves [7]. The nonresonant spatial mode could be removed with negligible reduction in power by passing the laser beam through a nondegenerate Fabry–Perot cavity, such as that located at the input to the interferometer in the GW application.

In TL, the incident laser beam is misaligned slightly with respect to the optical axis of the cavity, and the non- TEM_{00} component of the incident field becomes a mostly TEM_{01} spatial mode. This component will be reflected by the cavity with no phase change if the difference between the frequencies of the cavity's TEM_{00} and TEM_{01} modes is large compared to their linewidths. The phase (and amplitude) of the reflected TEM_{00} component, however, will depend on the difference between the frequency of the incident light and the frequency of the cavity TEM_{00} mode.

An error signal can be produced by comparing the interference between the phase-shifted TEM_{00} component and the two halves of the “phase reference” TEM_{01} component using a split photodiode. The two lobes of the TEM_{01} component must be in anti-symmetric phase quadrature with the TEM_{00} component at resonance. Thus, if the photodiode is in the near field, then the TEM_{01} component is generated by tilting the master laser beam. If, however, the photodiode is in the far field, then the phase change due to the Gouy phase requires that the TEM_{01} component be generated by laterally displacing the master laser beam. In practice, the mix of tilt and lateral displacement is adjusted to produce a suitable error signal.

At zero frequency difference (resonance), the two outputs of the photodiode are equal in amplitude but have opposite phases.

Manuscript received October 17, 2000; revised January 22, 2001.

D. J. Ottaway, C. Hollitt, P. J. Veitch, and J. Munch are with the Department of Physics and Mathematical Physics, Adelaide University, Adelaide, SA 5005, Australia.

M. B. Gray, D. A. Shaddock, and D. E. McClelland are with the Department of Physics, Australian National University, Canberra, ACT 0200, Australia.

Publisher Item Identifier S 0018-9197(01)03475-3.

These two outputs are added together, giving a zero resultant output. At nonzero frequency difference, the TEM₀₀ field interferes more constructively with one of the TEM₀₁ lobes and more destructively with the other (see [15]). Thus, the net current from the photodiode becomes either positive or negative depending on the sign of the frequency difference, and an error signal can, therefore, be produced.

In this paper, we demonstrate for the first time the use of TL for stabilizing an injection-locked laser. We investigate in detail the tradeoff between the misalignment required to produce a suitable error signal and the concomitant reduction in the injection-locking range, due to the decrease in the TEM₀₀ power injected into the slave resonator. A similar effect is observed in PDH systems where power is transferred into the modulation sidebands, which are reflected at the output coupler of the slave laser.

As discussed earlier, TL requires that the slave resonator be nondegenerate. We show that for our slave laser, which is particularly simple and contains no intra-cavity elements, there exists a tilt/lateral displacement where a suitable error signal can be obtained with only a slight reduction in locking range. Finally, we also show that the sensor noise in our TL stabilization system is negligible compared to the frequency noise of the monolithic master laser, and thus that the TL system can produce an injection-locked laser with very low-frequency noise.

II. MODELING OF TL FOR INJECTION-LOCKED LASERS

In this section we model the tradeoff of TL error signal amplitude and injection-locking range for an injection-locked laser. We calculate the coupling of the master laser into the TEM₀₀ and TEM₀₁ modes of the slave laser as a function of tilt angle and lateral displacement, and show that an error signal that has a useful amplitude can be generated with only a slight reduction in the locking range.

The spatial modes of a geometrically stable optical cavity form a complete set of orthogonal modes [11]. The field of the incident master laser beam E_{master} can thus be expressed as a linear combination of the spatial modes of the slave laser resonator

$$E_{\text{master}}(x, z) = \sum_{n=0}^N c_n u_n(x, z) \quad (1)$$

where the overlap coefficients c_n are given by

$$c_n = \int_{-\infty}^{\infty} E_{\text{master}}(x, 0) u_n(x, 0) dx. \quad (2)$$

Here, $u_n(x, z)$ are the normalized amplitudes of the spatial modes of the resonator, in one transverse dimension

$$u_n(x, z) = \left(\frac{2}{\pi}\right)^{1/4} \left(\frac{\exp[j(2n+1)\psi(z)]}{2^n n! w(z)}\right)^{1/2} \times H_n\left(\frac{\sqrt{2}x}{w(z)}\right) \exp\left[-jkz - j\frac{kx^2}{2R(z)} - \frac{x^2}{w^2(z)}\right]$$

where

$$w^2(z) = w_0^2 \left[1 + \left(\frac{\lambda z}{\pi w_0^2}\right)^2\right]$$

$$R(z) = z \left[1 + \left(\frac{\pi w_0^2}{\lambda z}\right)^2\right]$$

$$\psi(z) = \arctan\left(\frac{\lambda z}{\pi w_0^2}\right)$$

and where w_0 is the waist size and z is the displacement from the waist. At the waist, the zeroth and first-order modes of the cavity can be written [16]

$$u_0(x, 0) = \left(\frac{2}{\pi w_0^2}\right)^{1/4} \exp\left[-\frac{x^2}{w_0^2}\right]$$

$$u_1(x, 0) = \left(\frac{2}{\pi w_0^2}\right)^{1/4} \frac{2x}{w_0} \exp\left[-\frac{x^2}{w_0^2}\right].$$

We will consider two types of misalignment: a tilt of the master laser beam about an axis that lies in the plane of its waist and passes through the mode's optical axis, and a lateral displacement of the master laser beam. The field of the tilted master laser beam can be written [16]:

$$E_{\text{master}}(x, 0) = \left(\frac{2}{\pi w_0^2}\right)^{1/4} \exp\left[-\frac{x^2}{w_0^2} + jk\phi x\right] \quad (3)$$

where ϕ is the tilt angle of the master laser beam. The field of the laterally displaced beam can be written

$$E_{\text{master}}(x, 0) = \left(\frac{2}{\pi w_0^2}\right)^{1/4} \exp\left[-\frac{(x-a)^2}{w_0^2}\right] \quad (4)$$

where a is the lateral displacement.

If $\phi \ll \theta_{ff}$, the far-field diffraction angle of the Gaussian beam, then (3) can be written [16]

$$E_{\text{master}}(x, 0) \approx u_0(x, 0) + j\left(\frac{\phi}{\theta_{ff}}\right) u_1(x, 0). \quad (5)$$

If $a \ll w_0$, then (4) can be written

$$E_{\text{master}}(x, 0) \approx u_0(x, 0) + \left(\frac{a}{w_0}\right) u_1(x, 0). \quad (6)$$

Thus, for small misalignments, the amplitude of the TL error signal, which is proportional to the amplitude of the TEM₀₁ component, increases linearly with the misalignment. However the injection-locking range, which is proportional to the amplitude of the TEM₀₀ component, is essentially unchanged.

The predicted increase in the amplitude of the TL error signal and the associated decrease in the locking range as ϕ or a increases is shown in Fig. 1. A tilt of half the far-field divergence angle or a lateral displacement of half the waist size would result in $c_1 = 0.44$ and $c_0 = 0.88$. Thus, the error signal would be $\sim 3/4$ of the maximum possible value while the locking range would be reduced by only 12%. For both types of misalignment, up to 37% of the incident power could be transferred into the TEM₀₁ component, at the expense of a 63% reduction in

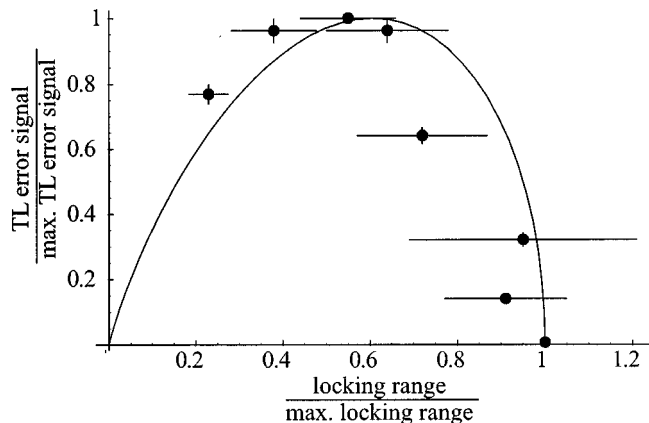

Fig. 1. Parametric plot of the amplitude of the TL error signal, normalized by the maximum amplitude, against the injection-locking range, normalized by the maximum range, as the misalignment is varied. The solid line is the theoretical prediction while the dots are the measurements (see Section IV-B).

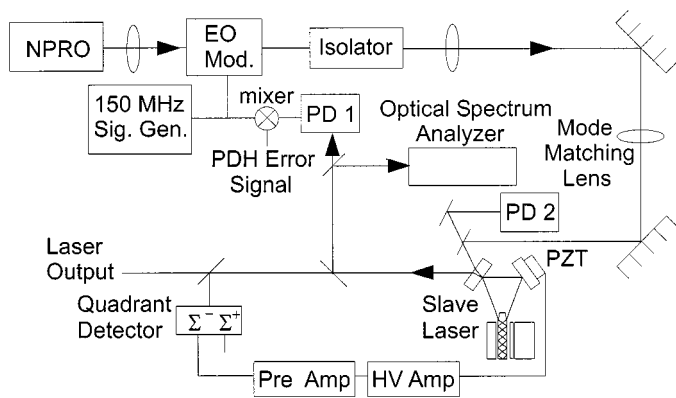

Fig. 2. Schematic of the experimental layout showing both the PDH and TL discriminators. The bandwidth of PD1 was >200 MHz.

the power coupled into the TEM_{00} mode. The tilt (lateral) displacement required to obtain the maximum transfer is $\phi = \theta_{ff}$ ($a = w_0$).

III. EXPERIMENTAL SET-UP

We designed an experiment to compare directly the stabilization of injection-locking using PDH and TL systems, as shown in Fig. 2. The master laser is a LZH-450 monolithic non planar ring oscillator (NPRO).¹ The slave laser has been described in detail elsewhere [8], [9]. Briefly, it has a free-spectral-range of about 2.0 GHz, and can produce diffraction-limited TEM_{00} output of 5 W when pumped with a single 20-W laser diode array. The beam has a waist, of approximate dimensions 0.35-mm wide and 0.15-mm high (radii), about mid-way between the resonator mirrors. Injection-locking is used to enforce unidirectional slave-laser operation but an optical isolator is still necessary to protect both the electrooptic modulator and the NPRO master laser from optical damage due to the reverse wave of the free-running slave laser.

For this experiment, we chose to operate the slave laser with an output power of 3 W. A master laser power of 0.1 W was in-

cident on the output coupler of the slave, which yielded a maximum injection-locking range of about 12 MHz.

The electrooptic modulator in Fig. 2 imposes 150-MHz phase-modulation sidebands on the master laser beam which are used to generate the PDH error signal, which appears at the IF port of the (double-balanced) mixer (DBM). Photodiode PD2 is used to monitor the reverse wave of the slave laser, which should be extinguished by the injection-locking.

The TL error signal was generated using a vertical tilt and detected using the quadrant photodiode, which had the two quarters of the top and bottom halves added together. The difference between the two outputs was amplified using an instrumentation amplifier and then fed back to the piezo-electric transducer (PZT) so as to stabilize the injection-locking. In addition to adjusting the frequency of the slave laser, the feedback also horizontally displaces the slave mode, which would have generated a spurious error signal if we had used horizontal TL.

In practice, it is simple to generate a TL error signal; indeed, the typically less-than-perfect alignment of the master laser beam and the slave resonator generally produces a significant TL error signal. The TL error signal is thus sensitive to misalignment of the input and output optics, and beam wander of the master and slave lasers due, for example, to variations in the thermal lensing within the slave laser. Any misalignment will be directly converted into a change in frequency of the slave laser. However, when using compact lasers, such as the master and slave lasers used here, the entire injection-locked laser can be made small, which minimizes the optical paths between the components and produces a system that is insensitive to mechanical vibrations.

To provide the most robust servo and minimize noise, the zero-crossing of the error-signal should correspond to the center of the injection-locking range of the slave laser. Thus, the alignment of the master laser beam, slave resonator, and photodetector must be carefully adjusted. We do this by initially aligning the master laser beam and the beam from the free-running slave laser, and then ensuring that the quadrant photodetector is centered on the output of the injection-locked laser. The master laser beam is then tilted and its position (height) adjusted until the error-signal is symmetric.

IV. RESULTS

A. TL Error Signal

The shape of the TL and PDH error signals were recorded by scanning the frequency of the slave laser using a low-frequency voltage ramp which was applied to the PZT actuator. The error signals for the TL and the PDH systems are shown in Fig. 3. Note that, in our setup, the amplitude of the TL error signal is much larger than that of the PDH error signal and thus the TL servo system will have a larger front-end gain [15].

B. Tradeoff of TL Error Signal Amplitude and Injection-Locking Range

The amplitude of the open-loop TL error signal and the time for which the slave laser was injection-locked were recorded as the frequency of the slave laser was scanned at a constant rate, by applying a voltage ramp to the slave laser PZT. Injection-locking was sensed by monitoring the reverse wave using PD2. The

¹Manufactured by Laser Zentrum Hannover (LZH), Hannover, Germany.

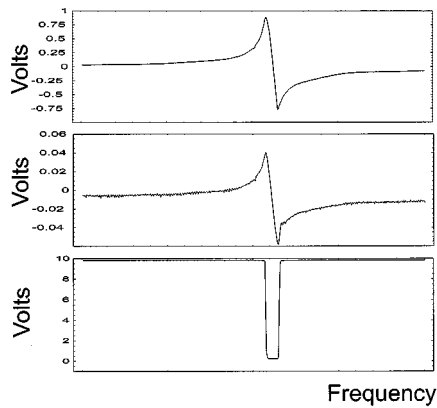

Fig. 3. Comparison of the TL and PDH error signals. (a) Output of the difference port of the quadrant detector (TL error signal). (b) Output of the DBM (PDH error signal). (c) Output voltage of PD2, which is proportional to the reverse wave power of the slave. The total width of the scan shown is 80 MHz.

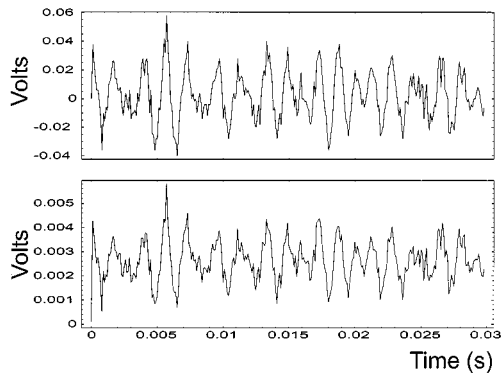

Fig. 4. Temporal comparison of the: (top) short-term fluctuations of the TL and (bottom) PDH error signals.

measurements were repeated several times for each tilt/lateral displacement and then repeated for a variety of displacements. The results are shown in Fig. 1. The relatively large uncertainty in the injection-locking ranges is due to the effect of ambient mechanical vibrations, which significantly affect the duration of the injection-locking. Nevertheless, the measurements agree roughly with the theoretical predictions, particularly the generation of a relatively large error signal with only a small decrease in injection-locking range at small misalignments.

C. Stabilization of Injection-Locking Using TL Error Signal

Injection-locking of the slave laser was stabilized using the TL system, and the fluctuation of the frequency of the slave relative to the frequency of the master laser was measured simultaneously using the PDH system. The short-term fluctuations of the TL error signal and the PDH signal are compared in Fig. 4. Spectra of these signals are shown as Figs. 5 and 6. The coherence of these spectra was very high, except at frequencies where they were contaminated by pickup of 50-Hz radiation and its harmonics. The difference between the signal levels in these figures is due to the different gains of the TL and PDH systems. Thus, it is apparent that the sensor noise in the TL system is insignificant compared to the frequency noise of the master laser at all measurement frequencies, and that the frequency noise of

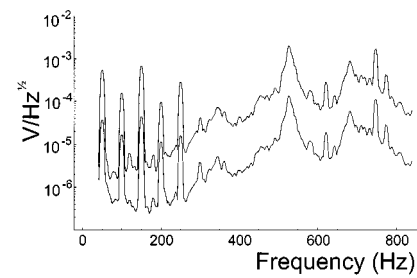

Fig. 5. Comparison of the low-frequency spectra of the: (top) TL error signal and (bottom) PDH error signal. The TL loop bandwidth was approximately 7 kHz.

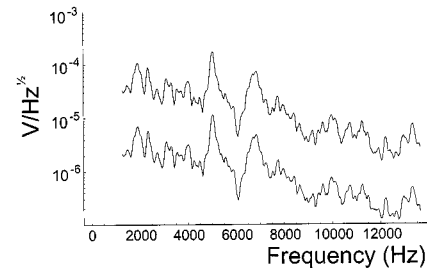

Fig. 6. Comparison of the audio-frequency spectra of the: (top) TL error signal and (bottom) PDH error signal.

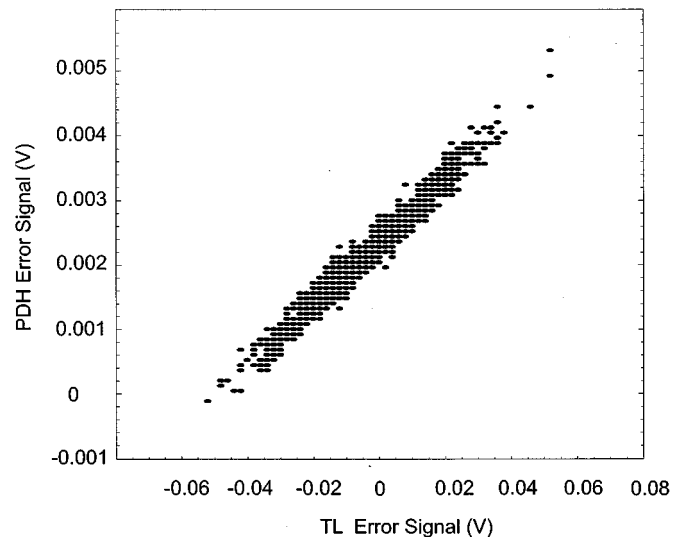

Fig. 7. Parametric plot of the PDH and TL error signals for a duration of 200 s.

the TL-stabilized injection-locked laser will be just that of the master laser.

A longer duration (200 s) comparison of the two error signals is shown in Fig. 7. The transverse spread of the data in this figure is due primarily to the differential contamination of the error signals by the pickup of 50-Hz radiation and its harmonics.

The long-term stability of the TL error signal was evaluated by injection-locking the slave laser using the PDH error signal and then measuring the dc drift of the TL error signal. Over a period of 20 min, the TL error signal was found to drift by less than 30 mV, which is comparable to the rms deviations (~ 20 mV) caused by acoustic noise in the laboratory and corresponds to less than 2% of the injection-locking range.

V. CONCLUSION

We have demonstrated, for the first time to our knowledge, the use of TL for stabilizing an injection-locked laser. This technique proved to be simple and robust. Large error signals were obtained for only minimal reductions in the injection-locking range. More importantly perhaps, the TL system was capable of accurately transferring the frequency stability of the NPRO master laser to the injection-locked laser without the need for, and complications of, an RF modulation/demodulation system. Thus, it is apparent that a TL system is particularly suitable for injection-locking of high-power lasers.

REFERENCES

- [1] O. Cregut, C. N. Man, D. Shoemaker, A. Brillat, A. Menhert, P. Heuser, N. P. Schmitt, and P. Zeller, "18 W single-frequency operation on an injection-locked, CW, Nd:YAG laser," *Phys. Lett. A*, vol. 140, no. 6, pp. 294–298, 1989.
- [2] C. D. Nabors, A. D. Farinas, T. Day, S. T. Yang, E. K. Gustafson, and R. L. Byer, "Injection locking of a 13-W cw Nd:YAG ring laser," *Opt. Lett.*, vol. 14, no. 21, pp. 1189–1191, 1989.
- [3] A. D. Farinas, E. K. Gustafson, and R. L. Byer, "Design and characterization of a 5.5-W, cw, injection-locked, fiber-coupled, laser-diode-pumped Nd:YAG miniature-slab laser," *Opt. Lett.*, vol. 19, no. 2, pp. 114–116, 1994.
- [4] I. Freitag, D. Golla, S. Knoke, W. Schone, A. Tunnermann, and H. Welling, "Amplitude and frequency stability of a pumped Nd:YAG laser output operating at a single-frequency continuous-wave output power of 20 W," *Opt. Lett.*, vol. 20, no. 5, pp. 462–464, 1995.
- [5] R. Barillet, A. Brillat, R. Chiche, F. Cleva, L. Latrach, and C. N. Mann, "An injection-locked Nd:YAG laser for the interferometric detection of gravitational waves," *Meas. Sci. Technol.*, vol. 7, pp. 162–169, 1996.
- [6] S. T. Yang, Y. Imai, M. Oka, N. Eguchi, and S. Kubota, "Frequency-stabilized, 10-W continuous-wave, laser-diode end-pumped, injection-locked Nd:YAG laser," *Opt. Lett.*, vol. 21, no. 20, pp. 1676–1678, 1996.
- [7] G. Mueller and K. Ueda, "Stabilization of injection-locking using polarization spectroscopic technique," *Jpn. J. Appl. Phys.*, vol. 37, pp. 3313–3318, 1998.
- [8] D. J. Ottaway, P. J. Veitch, M. W. Hamilton, C. Hollitt, D. Mudge, and J. Munch, "A compact injection-locked Nd:YAG laser for gravitational wave detection," *IEEE J. Quantum Electron.*, vol. 34, pp. 2006–2009, Oct. 1998.
- [9] D. J. Ottaway, P. J. Veitch, C. Hollitt, D. Mudge, M. W. Hamilton, and J. Munch, "Frequency and intensity noise of an injection-locked Nd:YAG ring laser," *Appl. Phys. B*, vol. 71, pp. 163–168, 2000.
- [10] R. Adler, "A study of locking phenomena in oscillators," *Proc. IRE*, vol. 34, pp. 351–357, 1946.
- [11] A. E. Siegman, *Lasers*. Mill Valley, CA: Univ. Science Books, 1986.
- [12] R. W. P. Drever, J. L. Hall, F. V. Kowalski, J. Hough, G. M. Ford, A. J. Munley, and H. Ward, "Laser phase and frequency stabilization using an optical resonator," *Appl. Phys. B*, vol. 31, pp. 97–105, 1983.
- [13] D. Mudge, P. J. Veitch, J. Munch, D. Ottaway, and M. W. Hamilton, "High-power diode-laser-pumped CW solid-state lasers using stable-unsaturated resonators," *IEEE J. Select. Topics Quantum Electron.*, vol. 3, pp. 19–25, 1997.
- [14] D. Mudge, M. Ostermeyer, P. J. Veitch, J. Munch, B. Middlemiss, D. J. Ottaway, and M. W. Hamilton, "Power scalable TEM₀₀ CW Nd:YAG laser with thermal lens compensation," *IEEE J. Select. Topics Quantum Electron.*, vol. 6, pp. 643–649, 2000.
- [15] D. A. Shaddock, M. B. Gray, and D. E. McClelland, "Frequency locking a laser to an optical cavity using spatial mode interference," *Opt. Lett.*, vol. 24, pp. 1499–1501, 1999.
- [16] D. Z. Anderson, "Alignment of resonant optical cavities," *Appl. Opt.*, vol. 23, no. 17, pp. 2944–2949, 1984.

D. J. Ottaway received the B.Sc. (Hons.) degree in 1994 and the Ph.D. degree in physics in 1999, both from The University of Adelaide, South Australia. His Ph.D. research involved the development and control of stable laser sources for high-precision metrology.

He is currently a California Institute of Technology post-doctoral scholar based at the LIGO Hanford site in Washington.

M. B. Gray received the Ph.D. degree from the Australian National University (ANU), Canberra, Australia, in 1995.

He has been with ANU as a Research Associate, working on the development of advanced interferometer configurations for gravitational wave detectors. He has also been a Visiting Scientist with California Institute of Technology, Pasadena, developing novel interferometric sensors, and a CNRS Fellow at the Laboratoire de l'Accélérateur Linéaire, Orsay, France, developing high-power injection-locked ultra-stable solid-state lasers. In 2000, he joined Redfern Optical Components, where he is a Photonics Engineer. His research interests include the development of ultra-stable solid-state lasers, novel fiber lasers, fiber gratings, free-space optical sensors, and non-linear optics.

D. A. Shaddock received the Ph.D. degree from the Australian National University (ANU), Canberra, in 2001. During his Ph.D. work, he investigated control systems for complex interferometer configurations for advanced gravitational wave detectors.

He is now a Research Associate at ANU, working on advanced configurations of gravitational wave detectors and the development of interferometric optical sensors.

C. Hollitt received the B.E. degree in electrical and electronic engineering and the B.Sc. degree, both from the University of Adelaide, Adelaide, Australia, in 1994 and 1996, respectively, where he is currently working toward the Ph.D. degree, studying thermal and thermoelastic noise in the test masses for interferometric gravitational wave detectors.

P. J. Veitch received the Ph.D. degree from the University of Western Australia (UWA), Perth, Australia, in 1987.

Until 1989, he was a Research Associate at UWA, working on the development of cryogenic resonant-bar gravitational wave detectors. From 1989 to 1991, he was with the University of Glasgow, Glasgow, Scotland, developing a prototype laser-interferometric gravitational wave detector. In 1992, he joined the Optics and Lasers Group at Adelaide University, Adelaide, Australia, where he is now a Senior Lecturer in the Department of Physics and Mathematical Physics. His research interests include the development of high-power single-frequency stable Nd:YAG lasers for gravitational wave detection, the development of pulsed Er:glass lasers for coherent laser radar, wave-front sensing using Hartmann-type sensors, adaptive optics, and holographic correction of low-cost large-aperture mirrors for LIDAR applications.

J. Munch was born in Denmark in 1945. He received the B.S. degree from Massachusetts Institute of Technology, Cambridge, and the M.S. and Ph.D. degrees from the University of Chicago, Chicago, IL.

He currently holds the Chair of Experimental Physics at Adelaide University, where he has established a research group concentrating on the physics of lasers, frequency stabilization, nonlinear optics, holography, photonics, and general optics. Prior to moving to Adelaide in 1990, for 16 years he was a Senior Scientist with TRW, Redondo Beach, CA, where he was working on laser development and nonlinear optics.

D. E. McClelland received the Ph.D. degree from the University of Otago (UO), New Zealand, in 1987.

He was awarded a Beverly Research Fellowship in Physics at UO before being appointed to the Australian National University, Canberra, as a Lecturer in 1988. He is now a Reader in the Department of Physics and Theoretical Physics at The Australian National University. His research interests include the development of optical techniques for second generation laser interferometer based gravitational wave detectors, gravitational wave data analysis, and the generation and application of squeezed states of light.