



A TAXONOMIC REVISION OF
PROSTANTHERA Labill. SECTION *KLANDERIA* (F.v. Muell.) Benth.
(LABIATAE)

by

Barry John Conn, M.Sc., B.Sc.Ed. (MELB.)

Department of Botany,
University of Adelaide

Thesis presented for the Degree of Doctor of Philosophy
at the University of Adelaide

June, 1982

TABLE OF CONTENTS

Abstract	iv
Declaration of Originality	vi
Acknowledgements	vii
Introduction	1
Taxonomic History	5
Methods, Materials and Presentation	8
Discussion of Selected Morphological Characters	11
Habit	11
Indumentum	12
Leaves	13
Inflorescence	14
Prophylls	20
Calyx	20
Corolla	21
Androecium	22
Disc and Gynoecium	24
Fruits and Seeds	25
Pollination and Floral Biology	
Introduction	26
Field Observations	26
Pollination mechanism in section <u>Klanderia</u>	27
Pollination mechanism in section <u>Prostanthera</u>	28
Floral biology and ornithophily in section <u>Klanderia</u>	28
Breeding system in section <u>Klanderia</u>	31

Seed Dispersal and Seedling Establishment	33
Numerical Analysis	
Introduction	34
Selection of Morphological Characters	36
Pre-numerical analysis	37
Method used to select morphological characters	38
Evaluation of character set	44
Numerical analyses of specimens	52
Numerical analysis of <u>Prostanthera aspalathoides</u>	66
Numerical analysis of the <u>Prostanthera calycina-</u> <u>P. microphylla-P. serpyllifolia</u> complex	70
Numerical analysis of the <u>Prostanthera laricoides</u> complex	76
Geographic Variation	83
Morphological variation in <u>Prostanthera aspalathoides</u>	85
Morphological variation in the <u>Prostanthera calycina-</u> <u>P. microphylla-P. serpyllifolia</u> complex	97
Morphological variation in the <u>Prostanthera laricoides</u> complex	112
Conclusion from Geographic Variation studies	125
Volatile Oils (Terpenoids)	127
Materials and methods	127
Numerical analyses of volatile leaf-oils of <u>Prostanthera aspalathoides</u>	131
Evaluation of volatile leaf-oil character set	131
Numerical analyses of specimens	131

Geographic variation of <u>Prostanthera aspalathoides</u>	
based on volatile leaf-oils	143
Function of volatile oils in <u>Prostanthera</u> : A	
discussion	151
Volatile oils as a defence against animals and	
insects	151
Volatile oils and pollination	153
Systematic Treatment	154
a. <u>Prostanthera</u> sect. <u>Prostanthera</u>	154
b. <u>Prostanthera</u> Labill. sect. <u>Klanderia</u>	156
Recognized taxa and their distribution	157
Key to Species	159
[Species Descriptions]	162
<u>Nomen sedis incertae</u>	257
Appendix	
Index to collections used in the numerical analyses	258
(a) Names of taxa of <u>Prostanthera</u> section <u>Klanderia</u>	
with their key numbers	258
(b) Enumeration of collections	259
References	265
Index to Scientific Names	
Index to plant names	286
Index to bird names	291

ABSTRACT

A taxonomic revision of *Prostanthera* section *Klanderia* is presented. General chapters on taxonomic history, morphology, pollination, and breeding systems precede the systematic treatment. Fourteen species are recognized of which seven are described for the first time. The new species are *P. florifera*, *P. incurvata*, *P. laricoides*, *P. monticola*, *P. patens*, *P. pedicellata* and *P. semiteres*. Two subspecies of *P. serpyllifolia* and two subspecies of *P. semiteres* are recognized. *P. semiteres* ssp. *intricata* is described for the first time. Keys to the species and subspecies are provided. All recognized taxa are provided with full descriptions, distribution information (including maps), ecological and other relevant notes. All species are illustrated.

Morphological variation of *P. aspalathoides*, the *P. calycina*-*P. microphylla*-*P. serpyllifolia* complex, and the *P. laricoides* complex, plus the volatile leaf oil variation of *P. aspalathoides*, were analysed with the multivariate numerical techniques: canonical variate analysis, principal components and principal factor analyses, principal coordinates analysis, surface trend analysis (contour mapping) and differential systematics. Manhattan metric distances were used as a measure of dissimilarity between individuals and/or groups. The univariate significance tests used were: *t* - test (often modified), *F* - test, and Student - Newman - Kuels multiple-range test (SNK).

Patterns of variation appeared to be associated with environmental and historical factors in *P. aspalathoides* and in the *P. caly-*

cina-*P. microphylla*-*P. serpyllifolia* complex. The distinctness of the Kangaroo Island populations appears to reflect the relatively long separation of this island from the mainland.

DECLARATION OF ORIGINALITY

I hereby declare that this thesis is my own work, except where specifically stated to the contrary. To my knowledge, it is not substantially the same as any other thesis which has been submitted to any University.

Barry J. Conn

ACKNOWLEDGEMENTS

I sincerely acknowledge the following people for the technical assistance which they generously provided: for computing techniques - Dr D.T. Blackburn (then ADU), Messrs P.J. Lang, C.J. Merrick, K.P. Nicholson (all ADU) and Dr T. Whiffin (Department of Botany, Latrobe Univ., Victoria); and for gas-liquid-chromatographic techniques - Drs E.V. Lassak (Biological & Chemical Research Institute, Rydalmere, New South Wales), R.H. Prager (Department of Organic Chemistry, Univ. of Adelaide, South Australia) and T. Whiffin.

I am indebted to the Directors and Curators of the many herbaria who made available loans of herbarium material. I am extremely grateful to Dr J.P. Jessop for making available the facilities at the State Herbarium of South Australia (AD).

I gratefully acknowledge the support of the National Parks and Wildlife Service of New South Wales, the Department of Environment and Planning (South Australia), the National Parks Authority of Victoria, and the Forests Commission of Victoria for freely granting permission to collect from areas under their control.

I wish to sincerely thank Drs D.C. Christophel (ADU) and J.P. Jessop for their continued interest in this study, the valuable discussions which I had with them and the detailed comments which they made on all aspects of the manuscript.

To Dr P.S. Short (MEL) I am thankful for his constructive criticisms of the manuscript.

The plant illustrations were skilfully done by Mrs H.M. Bennett (Fig. 53F), Ms A. Podwyszynski (MEL) (Figs 3 & 4) and Mr L. Dutkiewicz (AD)

(all other plant illustrations).

Mr & Mrs P. Althofer kindly offered their hospitality, field assistance and the facilities of the Burrendong Arboretum (New South Wales). Mr G. Althofer generously shared his extensive knowledge of the genus. I sincerely thank Mr & Mrs G. Jackson for their hospitality and field assistance on Kangaroo Island (South Australia).

I express my sincere appreciation to Misses C.E. Marcelline and T. Munro for carefully typing the manuscript.

Finally, I wish to express my deepest gratitude to Helen and my family for patiently enduring the many hours spent on this dissertation.

INTRODUCTION

Prostanthera species are evergreen sub-shrubs, shrubs or small trees (P. lasianthos) which are characterized by having decussate leaves, racemiform inflorescences, two-lobed calyces, four fertile two-celled anthers in each flower, terminal styles, and fruits composed of four mericarps. Prostanthera, with Eichlerago, Hemiandra, Hemigenia, Microcorys, Westringia and Wrixonia are grouped together in the subfamily Prostantheroideae of the Labiatae (Briquet 1895; Melchior 1964; Carrick 1976, 1977). Carrick (1977) offered a diagnosis for Prostantheroideae. His early paper (Carrick 1976) summarizes the key differences between all the genera in the subfamily (with the exception of Eichlerago which was not described at that time). The results from the work of Sharma & Singh (1982) on carpel morphology (refer pp. 24 & 25) require Carrick's diagnosis of the Prostantheroideae to be modified to:

Stamens 4, fertile, or only 2 (adaxial or abaxial pair sterile); style terminal (may superficially appear subgynobasic); fruit of 4 separate mericarps or entire, dry and indehiscent
(Eichlerago).

Comment on generic delimitations within the Prostantheroideae must await critical evaluation which is beyond the scope of this present study.

The Prostantheroideae are endemic to Australia with the most disjunct distribution being recorded by Jacobs & Pickard (1981) for Westringia fruticosa which they list as occurring on Lord Howe Island. Furthermore, this subfamily is the only one (of the Labiatae) in which any genus is endemic to Australia (Jessop 1980). The Prostantheroideae appear to be a distinct taxon of the Labiatae. This is indirectly verified by

the fact that the Prostantheroideae, as circumscribed by Bentham [as 'Tribus VII. Prostanthereae.' (Bentham 1834, p. 447); and Bentham & Hooker 1876], has been maintained almost unaltered by subsequent authors. Cunningham recognized the homogeneity and distinctness of the group of genera which are now classified within this subfamily as early as 1825 (Cunningham, in Field 1825). However, prior to 1834 the genera which are now regarded as belonging to the Prostantheroideae were frequently placed in separate infrafamilial groups (e.g. Reichenbach 1828; Bentham, in Lindley 1829-1830; Bartling 1830). Without evaluating the relationship between the subfamilies of the Labiatae, workers have usually regarded the Prostantheroideae as most closely related to the Ajugoideae (e.g. Briquet 1895; Hillson 1959).

The Prostantheroideae, together with the Ajugoideae and Rosmarinoideae, are regarded as transitional subfamilies between the remaining Labiatae and Verbenaceae (Cronquist 1981). The relationship between these two families and the general affinities of the Lamiales are discussed by several authors (Cantino 1982; Carrick 1977; Cronquist 1981; Munir 1978 and Thorne 1976).

During preliminary non-numerical taxonomic and ecological studies of Prostanthera section Klanderia, several taxonomic problems were recognized. It was noted that certain taxa had patterns of character variation which appeared to be very complex. Furthermore, some of these taxa appeared to intergrade such that it was difficult to distinguish between them. The taxa which make up the complexes (P. aspalathoides, P. calycina, P. serpyllifolia and the P. laricoides complex [including synonyms - refer 'Systematic Treatment']) were subsequently examined in detail so that various biometrical analyses could be carried out in an

attempt to simplify and visualize any underlying distribution pattern within these taxa. The results of the various analyses (refer 'Numerical Analysis') were used to suggest and to test hypotheses related to the relationship between the taxa. The information provided then formed a basis for the construction of a taxonomic classification scheme. Other taxa could be evaluated and distinguished using non-numerical taxonomic procedures because they were significantly distinctive.

The geographic variation found in P. calycina, P. serpyllifolia and P. laricoides was studied using morphological features as taxonomic characters. In P. aspalathoides the geographic variation was studied using both morphological and volatile leaf oils (terpenoids) as taxonomic characters. The results of these analyses were used to test hypotheses related to the relationship between these taxa and environmental factors.

Without undertaking a critical evaluation of Bentham's infrageneric classification (refer 'Taxonomic History'), section Klanderia appears to represent a natural group. As pointed out by Bentham (1870), 'the shape of the corolla is so different from [that of section Prostanthera] ... that this section might well be considered as a distinct genus ...'. Other morphological characters (refer pp. 152-254) and, to some extent, its distribution (compared with that of sect. Prostanthera) support the distinctness of this section. A canonical variate scattergram (function 1 versus function 2) of the volatile leaf oils of 38 species is illustrated in figure 1. This canonical variate analysis was based on 64 specimens (50 from Lassak 1980, tables 4 - 6; 14 from personal collections). Within the limits of the data, a consideration of the volatile leaf oils also suggests that sect. Klanderia is distinct from sect. Prostanthera. Since sect. Klanderia appears to represent a distinct group

within the genus, Bentham's sectional subdivision of Prostanthera is here accepted (Bentham 1870). A critical re-evaluation of Bentham's subdivision of sect. Prostanthera is premature until the whole genus is revised. However, the canonical variate scattergram (Fig. 1) suggests that series Racemosae is distinct from the other two series, whereas series Convexae and series Subconcavae are less distinct from each other (at least on the first two functions).

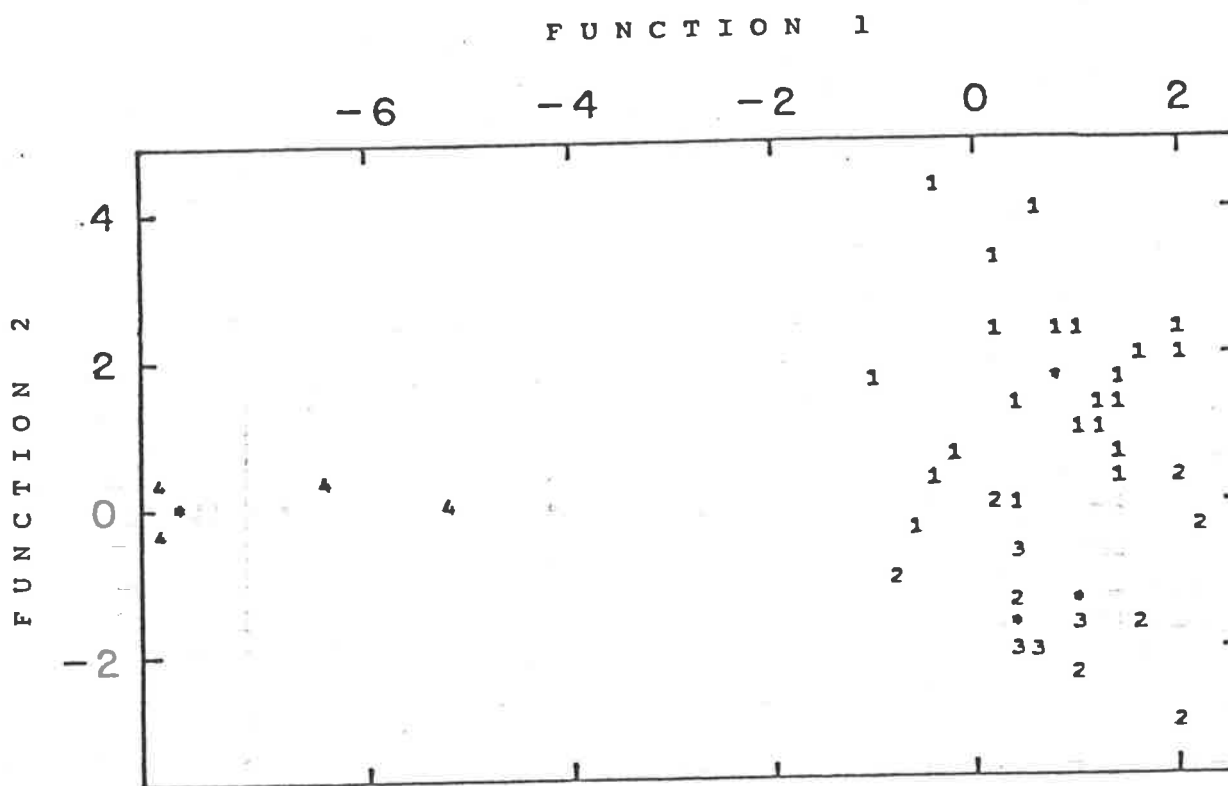


Fig. 1. Canonical variate scattergram (function 1 versus function 2) of the volatile leaf oils of *Prostanthera*. 1 = *Prostanthera* sect. *Prostanthera* series *Racemosae*; 2 = *Prostanthera* sect. *Prostanthera* series *Convexae*; 3 = *Prostanthera* sect. *Prostanthera* series *Subconcavae*; 4 = *Prostanthera* sect. *Klanderia*; * = group centroid.

TAXONOMIC HISTORY

Prostanthera was described in 1806 by Labillardière for P. lasianthos, a species from eastern Australia (Queensland, New South Wales, Victoria and Tasmania). Since then, a number of publications (e.g. Bentham 1834; Brown 1810; von Mueller 1876) have made significant contributions to our present understanding of Prostanthera Labill. However, the two most significant contributions on infrageneric concepts are those of Bentham (1870) and Briquet (1895).

While there has been general concensus on generic concepts, there has been less agreement on the subdivision of the genus. Bentham (1870) was the first to subdivide the genus into sections (sect. Prostanthera [as sect. 'Euprostanthera'] and sect. Klanderia). These sections were largely based on floral characters (refer pp. 152-156). He further subdivided section Prostanthera into three series (viz. series Racemosae [including the generic type, P. lasianthos], series Convexae and series Subconcaevae). These series were based on the position of the inflorescence, the type of bracts, and the shape of the leaves (Bentham 1870, pp. 91 & 92).

Moore (1893) subdivided the genus into two sections (viz. section I [=sect. Prostanthera] and section II [=sect. Klanderia]). He further subdivided section I into two groups (viz. undersection I [=series Racemosae Benth.] and undersection II [=series Convexae Benth. and series Subconcaevae Benth.]).

Briquet (1895) subdivided the genus into three sections (viz. sect. Depremesnilia [as sect. 'Depresmenilia' - typographical error], sect. Cryphia [=sect. Klanderia], and sect. Prostanthera [as sect.

'Euprostanthera']). Prostanthera chrysocalyx (F. v. Muell.) Briq. [= Depremesnilia chrysocalyx F. v. Muell., type species of sect. Depremesnila (F. v. Muell.) Briq.] was transferred to Pityrodia chrysocalyx (F. v. Muell.) Gardner (Chloanthaceae) by Gardner (1931). For further details refer Munir (1978, 1979).

Bentham chose von Mueller's generic name Klanderia as a sectional name, over the earlier name Cryphia (of R. Brown), because the latter name was derived 'from a character probably abnormal in the particular flower examined' (Bentham 1870, p. 105). Briquet (1895) chose Cryphia as the sectional name, presumably because it is the earlier generic name. However, since generic names do not have priority outside their own rank (Stafleu et al. 1978: Art. 60), Bentham's sectional name must be followed.

Briquet (1895) accepted Bentham's (1870) subdivision of sect. Prostanthera into series.

In 1970 Carrick began a revision of the genus. Only two publications (Carrick 1976, 1977) on related genera were completed before his death in 1978. He published a key to the recognized species of Prostanthera in Althofer (1978) and his contribution to the more formal taxonomic aspects of this book appears to be considerable. Unfortunately, he apparently had not finalized his concept of the genus. There is no manuscript and his occasional brief notes are insufficient to formulate any appreciation of his concepts in Prostanthera.

Approximately eighty species have been described, all from Australia. Nelson (1981) listed 60 previously described species of Prostanthera which were recognized by Carrick. However, he incorrectly cited the number of species for Tasmania as 19 (with 17 endemics). Carrick

(Barker, in litt.) actually recognized 3 species (with no endemics) for Tasmania. In addition to those listed in Nelson (1981), Carrick (Barker, in litt.) recognized 37 species for New South Wales (of which 19 are endemic) and 10 species for Queensland (of which 6 are endemic).

METHODS, MATERIALS AND PRESENTATION

The measurements of the morphological characters (for both numerical and non-numerical analyses) and the descriptions of all taxa were made from herbarium specimens. 605 specimens (refer 'Appendix') were used in the various biometrical analyses. Some of these specimens were replicate samples from the same individual, whereas others were replicate samples from local populations. The quantitative and qualitative values of the various characters (for each individual) as used for the numerical analyses, are the average of five separate observations. Although Blackburn (1980) pointed out the inadequacy of using mean character values as a measure of resemblance, particularly when character states overlap considerably between taxa, his method was not used because his data standardization procedure requires quantitative data to be grouped into a fixed number of class intervals (usually 8). Furthermore, the necessity to set class boundaries is regarded as inappropriate.

The descriptions were supplemented by personal field observations. In the descriptions, those character states which occur in one or a few specimens (hence, occur in fewer than 10% of the individuals in the relevant taxon) are enclosed by parentheses. Parentheses are also used to enclose rarely occurring character states which may be present in an otherwise typical individual specimen. No distinction is made between these two situations.

In general, usage of terms follows Lawrence (1955), Porter et al. (1973), and Stearn (1973). Author and literature abbreviations follow Stafleu & Cowan (1976, 1979, 1981). English nomenclature for Australian birds follow Schodde et al. (1978). I found that it was only necessary to recognize formally one level of variation within any single species. Therefore the proposal of Raven et al. (in Raven 1974) and the example

of Flora Europaea (refer Tutin et al. 1964) to use 'subspecies' as the only infraspecific category was followed in this treatment.

Although I began my revision of Prostanthera in 1979, most of the herbarium material of this genus had been on loan to the State Herbarium of South Australia (AD) since 1972/73. Collections on loan from the British Museum (BM) were returned, upon request, before many taxa were fully considered. In a number of cases this has prevented typification. I was reluctant to endanger the material further by requesting an additional loan of the relevant collections so soon after their return.

The citation of the type(s) immediately follows the most recent reference to the relevant taxon. The kind of nomenclatural type is listed first. This is followed by the collector (or 'Anon.' if not known), collection number (or 's. dat.' if not known) and finally collection locality (in that order). In parentheses after the locality, the institution which holds the principal nomenclatural type is given first (before the semi-colon), whereas the locality of the duplicates is given after the semi-colon.

The distribution of each taxon is briefly summarized after its description. The distribution summary and the selected citation of specimens examined are grouped according to various regional subdivisions. The regional subdivisions that I have used for the various states are: for Queensland I have followed the pastoral divisions used by the Queensland Herbarium (BRI) [as in Contr. Queensl. Herb. 19(1975) back end paper], for New South Wales those of Jacobs & Pickard (1981) (which is modified from Anderson 1961), for Victoria those of Cochrane et al. (1968), for South Australia those of Laut et al. (1977a, 1977b, 1977c, 1977d), and for Western Australia those of Beard (1980).

The ecological notes are taken from collector's notes on the labels of herbarium sheets, supplemented in most cases by personal field observations.

Herbarium abbreviations are those given in Holmgren et al. (1981). Since Kings Park and Botanic Gardens (West Perth, Western Australia) is not listed in 'Index Herbariorum', collections examined from this herbarium are referred to as 'KP'. Collections from the following herbaria were examined: A, AD, ADW, BM, BR, BRI, C, CANB, CBG, E, F, GH, GOET, HAL, HBG, HO, K, KP, L, LD, LE, LY, M, MEL, MO, NE, NSW, NT, NY, P, PERTH, S, SYD, UC, UP, US, W, WRSL, WU.

Herbarium material was studied at the State Herbarium of South Australia (AD), numerical analyses were carried out in the Botany Department of the University of Adelaide, and preliminary gas-liquid chromatographic analyses were carried out in the Organic Chemistry Department (University of Adelaide). The detailed gas-liquid chromatographic analysis of the volatile leaf oils of P. aspalathoides (as presented in this study), was carried out at the Biological and Chemical Research Institute, Rydalmere (N.S.W.).

DISCUSSION OF SELECTED MORPHOLOGICAL CHARACTERS

In this chapter a detailed discussion of various morphological structures, including the extent of morphological variation in sect. Klanderia is provided. Those characters which have been employed in the taxonomy of the group or those which are of potential taxonomic value are given particular emphasis. The definitions of terms which are used later in this revision are also provided.

Habit: All axes of the sub-shrubs or shrubs of Prostanthera sect. Klanderia have continuously active meristems. The plants are architecturally differentiated into a primary axis ('stem') and equivalent branches. Branching appears to occur more or less continuously. This shoot construction is referable to Attim's architectural model (Hallé et al. 1978). Periodicity of growth appears to be induced by seasonality and apparently is not endogenous.

The primary axis is frequently damaged. In such instances, adjacent lateral axes may 'replace' the primary one. If the primary axis of young plants is damaged, it may be very short, such that the usually many-branched, mostly erect small shrub appears to be multi-stemmed. The lower branches usually develop at or just above ground level. Some species form densely branched compact shrubs (a common habit form of P. aspalathoides), whereas others have fewer branches and an open habit (e.g. P. chlorantha and P. patens). P. walteri has a habit of tangled branches, especially in exposed situations. Semi-prostrate to prostrate forms are found in coastal forms of P. serpyllifolia (e.g. at Innes National Park and Cape Cassini, South Australia), and in the subalpine species P. walteri and P. monticola. The habit is modified by salt-pruning in P. serpyllifolia, but in the latter two species it is caused by

extremely low temperatures associated with the ice and snow. In more sheltered situations, these three species have the more typical semi-erect to erect habit.

In P. chlorantha adventitious shoots are occasionally present (Conn 685), developing from horizontal stems that are either on or just below the soil surface.

Indumentum: Both glandular and non-glandular trichomes are present. Non-glandular trichomes are here referred to as 'hairs' (refer descriptions in 'Systematic Treatment'), whereas glandular trichomes are referred to as 'glands'. Therefore, the various parts of a plant are described as glabrous or hairy (with reference to the non-glandular trichomes), irrespective of the presence or absence of glands.

The glandular trichomes ('glands') are more or less hemispherical (typical of those in many members of the Labiatae, cf. Uphof 1962, Fig. 55) and are particularly common on the distal parts of branches, on the outer surface of the calyx, and on the pedicel.

The non-glandular trichomes ('hairs') occur on most parts of the plants. P. pedicellata and P. semiteres have glabrous branches and leaves. However, all other species have some hairs on the vegetative parts. The hairs of the branches are frequently denser along two narrow zones (each on opposite 'sides' of the branches which extend from the leaf axil region to the next more distal nodal region (between the opposite leaf bases). The hairs tend to be denser on the distal (juvenile) portions of the branches. The hair density of the branches, as recorded in the descriptions, was measured from the second to fifth distal internodes.

The leaves are usually more densely hairy on the abaxial surface than adaxially. Frequently the hairs are restricted to the midrib

region of the abaxial surface and/or to the base of the leaf.

The pedicel, margin of prophylls, and the outer surface of the calyx and corolla (particularly on the respective lobes), are frequently hairy. The inner surface of the calyx is glabrous in most species. However, P. incurvata, P. laricoides, P. patens, P. pedicellata (usually), and P. semiteres (in this study all of these species are referred to as part of the P. laricoides complex of Western Australia) are hairy on the inner surface of the calyx. Sometimes these hairs are restricted to the distal positions of the calyx lobes.

The indumentum is usually more or less tomentose, sometimes becoming pilose. The hairs are more or less patent basally and recurved to reflexed distally, such that the hairs often appear curled. The hairs of P. calycina are appressed and are not curled. Furthermore, they are relatively long (up to 0.5 mm long) and stiff. Most species have simple one-celled hairs, however P. chlorantha (Fig. 54) and the Kangaroo Island populations of P. serpyllifolia ssp. microphylla have irregularly branched, multicelled hairs similar to those of Lavandula officinalis (Hummel & Staesche 1962, Fig. 8).

The density of hairs, particularly on the branches, is in general extremely variable and of little taxonomic value (e.g. refer P. semiteres, p. 112). The juvenile portions of the branches are usually relatively densely hairy. These hairs tend to be lost from the older branches. If plants were collected during growth-limiting conditions the amount of new growth would be very small and so, a low hair density would be recorded. Therefore, the density of hairs (on branches), as recorded in this study, may indirectly reflect the seasonal climatic conditions prior to the time of collection.

Leaves: The leaves of all species are decussate. They are more or less

terete (often slightly compressed) in P. aspalathoides, P. florifera, P. incurvata, P. laricoides, P. pedicellata, and P. semiteres. All of these species have leaves which are narrow and more or less oblong to oblanceolate (for details refer relevant species description in 'Systematic Treatment'). The petiole of these species is very short or absent. All remaining species usually have distinct, but often short-petiolate leaves. Ovate to suborbicular leaves are found in P. chlorantha, P. patens, P. serpyllifolia ssp. microphylla, and occasionally in P. ringens. Normally, the leaves of P. ringens and P. serpyllifolia ssp. serpyllifolia are more or less flat and oblong to obovate. P. monticola and P. walteri have the largest leaves (for the section) which are relatively broad. P. grylloana has spatulate conduplicate leaves.

The leaf margin is frequently recurved, except for those species with more or less terete leaves. In many instances the recurvature of the margin is, at least in part, a response to water stress and so, is probably of dubious taxonomic value. The leaves of P. grylloana appear to respond to water stress by becoming strongly conduplicate, thus reducing the exposed adaxial surface area of the leaf.

The lamina shape, size, and other features (as discussed above), are frequently useful supplementary characters, particularly for verifying initial determinations.

Inflorescence: Carrick (in Althofer 1978) and all previous workers have regarded the inflorescence of section Klanderia as lateral (axillary), with each inflorescence being a single flower. A detailed re-evaluation of the structure of the inflorescence is not possible until the whole genus has been studied. In fact, it would be premature to undertake such an evaluation until the inflorescence structure of all genera in the

subfamily Prostantheroideae has been examined. However, it is possible to give a brief tentative interpretation of the inflorescence structure for the genus.

Architecturally, the inflorescence of section Klanderia is pleo- :
 nanthic (sensu Hallé et al. 1978) since flowering usually coincides with shoot expansion. All floral [=flower-producing] axes end in non-floral buds [hence, \sim indeterminate] (Fig. 2). Briggs and Johnson (1979) regard this structural type as blastotelic [\sim polytelic, Troll 1964 & 1969] and, since the R_z axes (refer Fig. 2) continue to grow beyond the flowering region, they are auxotelic. The uniflorescences (Briggs & Johnson 1979) [unit inflorescences, Johnson & Briggs 1975, Johnson 1976; \sim partial inflorescences, partial florescences, Troll 1964 & 1969; Weberling 1965, 1981, 1982] are monadic and the resulting conflorescence [= synflorescence, Troll 1964 & 1969] is racemiform on leafy branches (Fig. 2).

In section Prostanthera similar frondose racemiform conflorescences (with monadic uniflorescences) are found in P. caerulea, P. cuneata, P. eckersleyana, P. spinosa, and P. teretifolia. P. rotundifolia and P. stricta (both sect. Prostanthera) have a bracteose blastotelic racemiform conflorescence (with monadic uniflorescences) on anauxotelic R_z axes (Fig. 3a), since the axis is terminated by an aborted vegetative bud. In P. lasianthos (Figs 3b & 4) and P. ovalifolia, the racemiform conflorescences are arranged into a superconflorescence (sensu Briggs & Johnson 1979).

In Prostanthera the monadic uniflorescences can be regarded as derived from the cymose condition by reduction because the primary (penultimate) axis [a_1 axis, Briggs & Johnson 1979] is uninodate with a pair of prophylls [Vorblätter, Troll 1964, 1969] occurring at this distal node (Fig. 2). Furthermore, the ultimate 'internode' [anthopodium, Briggs & Johnson 1979]

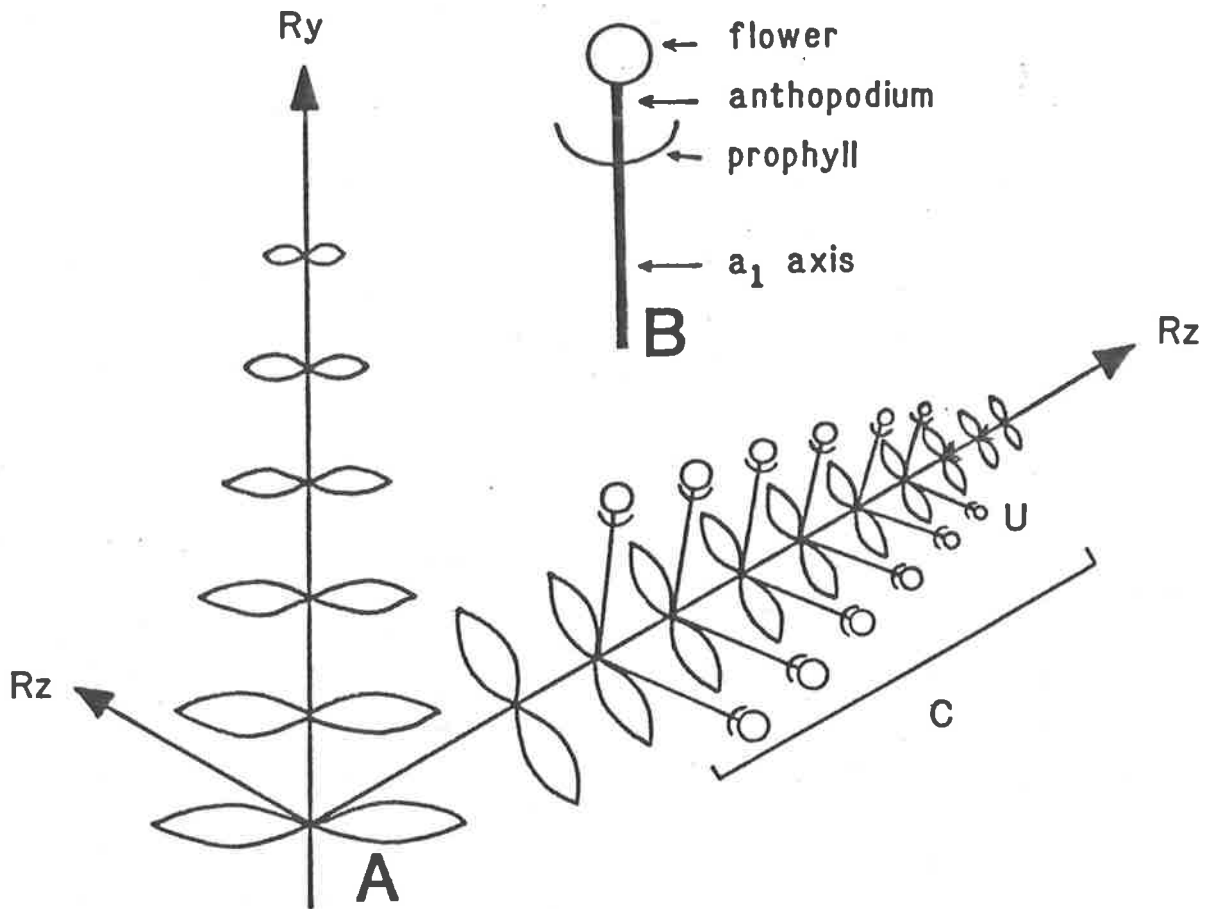


Fig. 2. Diagrams of a typical flowering branch of *Prostanthera* sect. *Klanderia*. A. general diagram; B. detail of uniflorescence. C = conflorescence; Ry = the branch from which the Rz axis arises; Rz = the branch from which the a_1 axis arises; U = uniflorescence.

Fig. 3. Diagrams of typical inflorescences of Prostanthera
sect. Prostanthera. a. Flowering branch of P. rotundifolia
(Live material, Royal Botanic Gardens, Melbourne); b. Flowering
branch of P. lasianthos (Ashby 4454, AD).

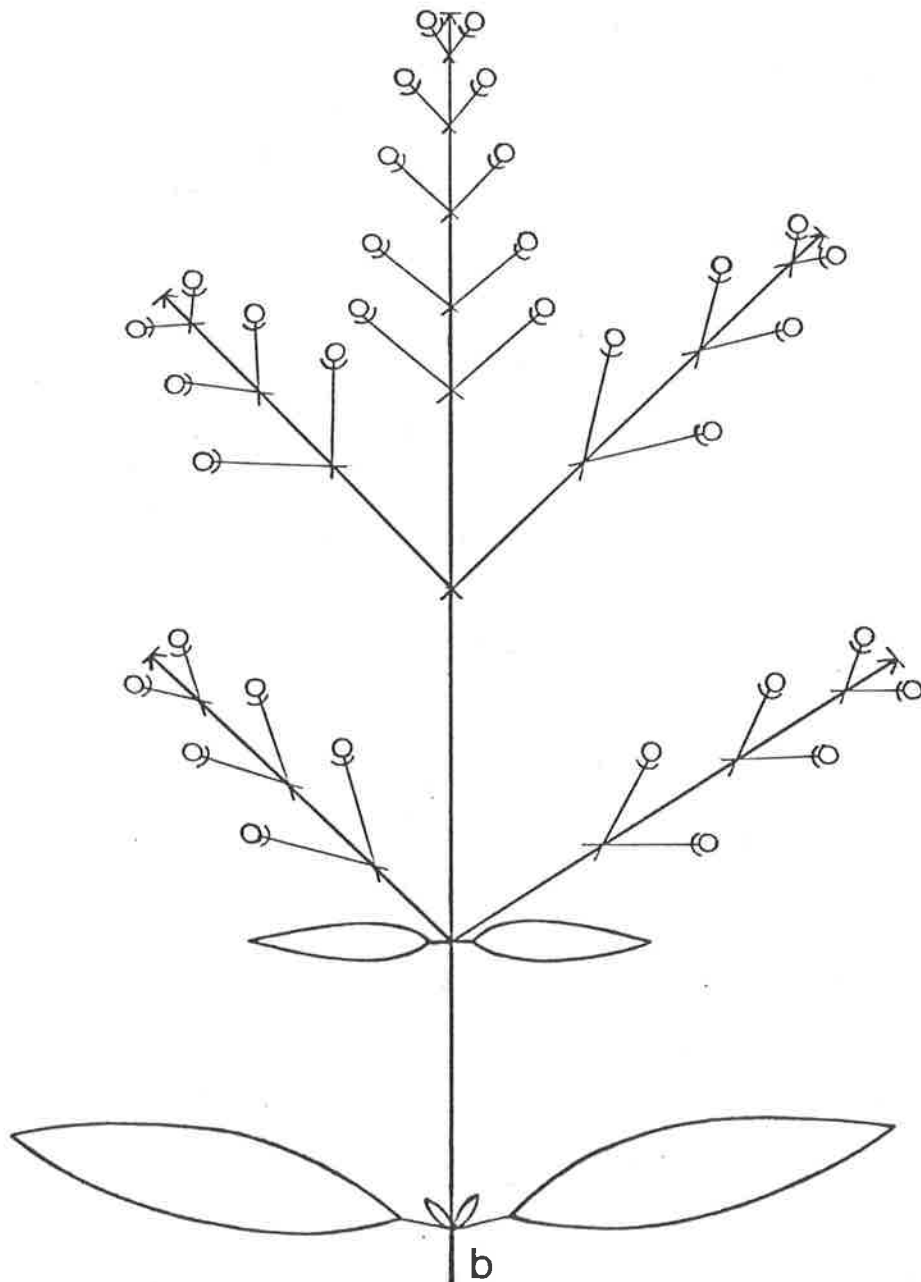
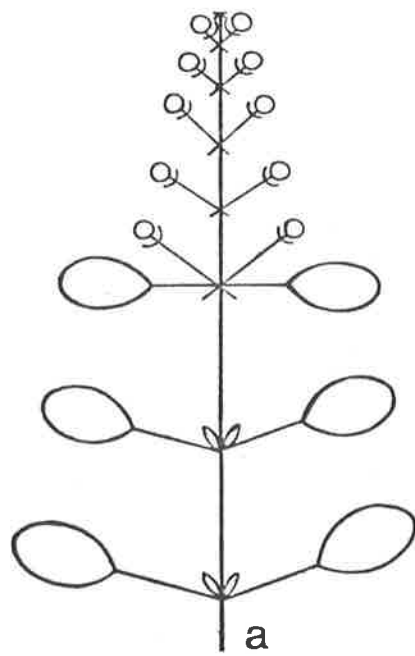
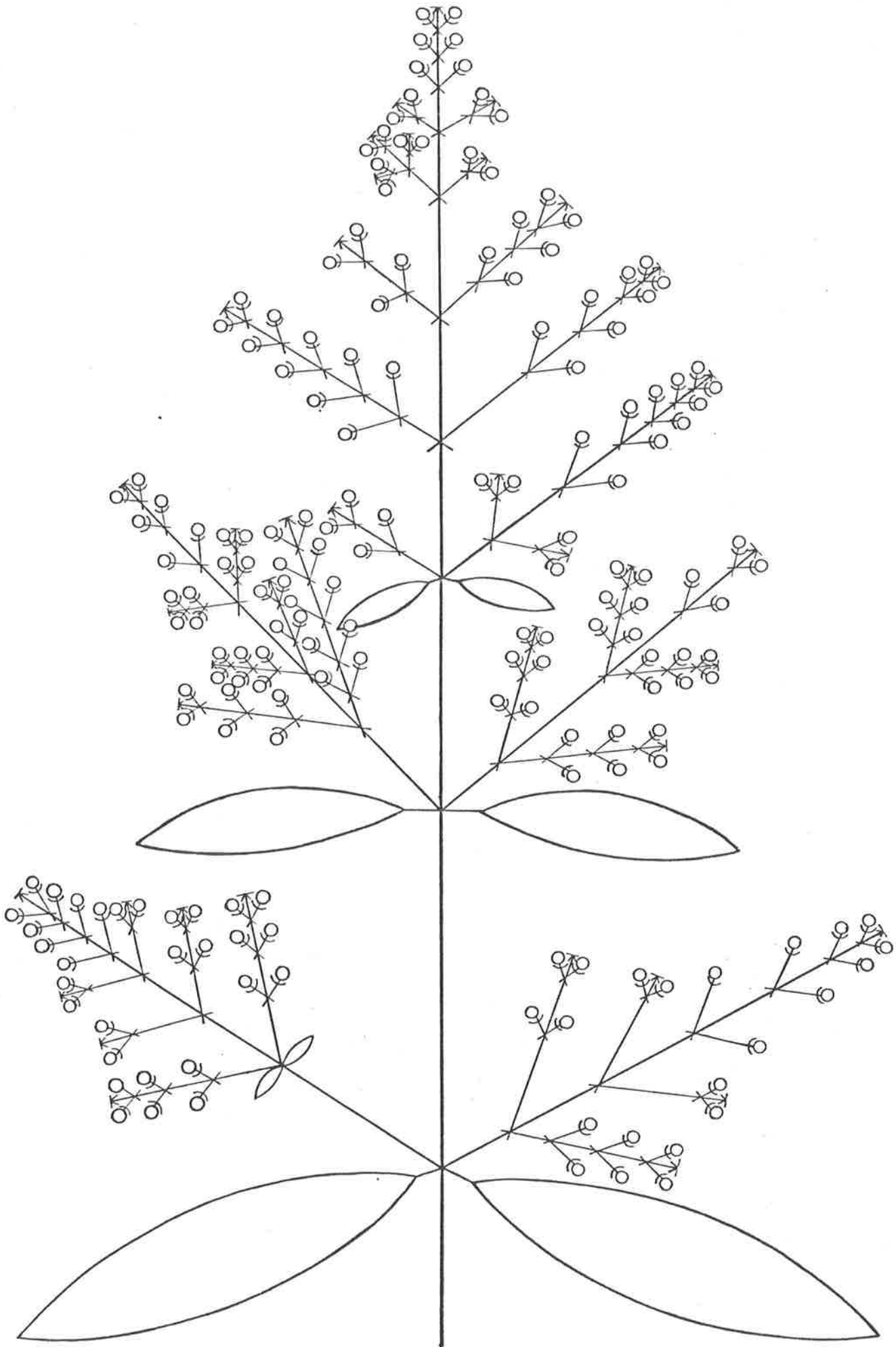


Fig. 4. Diagram of inflorescence of Prostanthera lasianthos.
(Ashby 5304, AD).



is terminated by a flower (Fig. 2). The above initial re-evaluation of the inflorescence structure of Prostanthera supports the findings of Troll (1964) and Weberling (1965). They concluded that all of the labiate genera which they had studied, have polytelic synflorescences with "cymose 'partial florescences'" (Weberling 1965) [= cymose uniflorescences, Briggs & Johnson 1979]. For examples of cymose inflorescences of several labiates refer to Troll (1964, Figs 62-68). Frondose racemiform conflorescences, typical of section Klanderia are also found in Westringia (except W. cephalantha which has a bracteose conflorescence similar to P. rotundifolia). Other examples of labiates with monadic uniflorescences are Salvia patens (Troll 1964, Fig. 73II) and Teucrium fruticans.

Since the prophylls are closely associated with the developmental sequence of the flower, the ultimate 'internode' is thought to represent the last infrafloral region (Briggs & Johnson, 1979). In the Myrtaceae Schmid (1972, Fig. 24) and Briggs & Johnson (1979) have frequently found that the transition from the base of the flower to the anthopodium is externally very indistinct. Therefore, the axis distal to the prophylls is actually the basal part of the flower and, as pointed out by Schmid, is also anatomically indistinguishable from the primary axis (a_1 axis, Briggs & Johnson; pedicel, Schmid), except where the vascular traces diverge to the prophylls. The validity of distinguishing the ultimate and penultimate flower-bearing axes requires further evaluation. The applicability of such a distinction in Prostanthera is not known at this stage. However, it is of interest to note that Tölken found a developmental differentiation between the two 'internodes' in Crassula (Toelken [Tölken].1981). The anthopodium ('pedicel', Toelken

1981) of Crassula pedicellosa elongates as the fruit matures, but the a_1 axes ('peduncle', Toelken 1981) does not elongate. In section Klanderia it appears to be the a_1 axis (if any) which elongates as the fruit matures, not the anthopodium. In the 'Systematic Treatment', pedicel is regarded as the a_1 axis plus the anthopodium.

Prophylls ('bracteoles'): In sect. Klanderia the prophylls usually occur near or at the base of the calyx (hence, anthopodium reduced). The anthopodium is relatively long in P. patens and P. ringens, and is of some taxonomic value for distinguishing them from the remaining species of this section. The prophylls are soon deciduous in P. patens. They are usually narrow, more or less lanceolate to oblanceolate in most species. Those of P. patens are narrower than for the other taxa.

The prophylls are usually opposite, but in P. chlorantha they are occasionally displaced vertically, relative to each other, such that they appear to be alternate.

Calyx: The calyx varies from 4 to 15 mm long. P. calycina, P. chlorantha, P. monticola, and P. walteri have calyces which are at least 8 mm long. The other species usually have smaller calyces. The calyx is 2-lobed, with the more or less triangular lobes being approximately equal in length (Fig. 53).

Since the calyx frequently enlarges as the fruit matures, the description of the calyx, including all measurements, is based on flowering material. In fruiting material the calyx lobes remain more or less porrect (Fig. 53) unlike those in section Prostanthera, where the abaxial lobes incurves to cover the fruit (Fig. 52).

The calyx varies from green to maroon. Certain species appear to have only one colour (e.g. P. florifera has only maroon calyces), whereas

other taxa (e.g. P. serpyllifolia ssp. microphylla) have populations which show the full colour range. The taxonomic significance of the colour variation is not known, but it is thought to be of little importance.

Corolla: The corolla tube is slightly incurved and varies from 9 to 17 mm long. In cross-section it is more or less elliptic, frequently elliptic-ovate. The throat and mouth are slightly expanded so that the maximum width at the mouth (along shortest axis) is approximately 5 mm. [The shortest axis of the mouth is more or less equivalent to the distance between the bases of the two lateral lobes.]

The corolla is normally described as being bilabiate (2-lipped) (e.g. Bentham 1870; also refer recent flora accounts). However, the position of the two lateral lobes is such that it is frequently difficult to decide (using macromorphological features) to which lip they belong (e.g. cf. Figs 53C, 70B & 73C). To avoid possible confusion, the corolla is described as being 5-lobed: comprising two adaxial, two lateral, and one abaxial. The two adaxial lobes are more or less completely fused and are referred to, collectively, as the adaxial median lobe-pair (Fig. 53, also refer species descriptions).

The anthers, style and stigma tend to lie next to the adaxial part of the inner surface of the corolla tube. Therefore, the lobes which are an extension of this adaxial surface are the adaxial median lobe-pair. Since the pedicel (a_1 axis + anthopodium) frequently twists through at least ninety degrees, the position of the anthers, style and stigma can be used to avoid orientation problems when attempting to locate the adaxial lobe-pair. This terminology also avoids the possible confusion arising from the application of the terms upper and lower lips, which are commonly

used by other workers.

All lobes (except the adaxial lobe-pair, which is more or less porrect) become more recurved or more strongly reflexed once the anthers have fully dehisced.

The species of section Klanderia have corollas which are usually red, often green, and occasionally yellow. Many species, e.g. P. aspalathoides, show the full colour range, whereas others, e.g. P. chlorantha, P. ringens, P. monticola and P. walteri have more or less green corollas only. It was found that when the corolla is placed in 100% ethyl alcohol, all colour forms turned red (sometimes very faintly). In contrast, the corollas of the species (23 species tested) of section Prostanthera almost invariably turned blue when placed in 100% ethyl alcohol, irrespective of original colour. The only exception was that white corolla forms (of sect. Prostanthera) became translucent to transparent. Therefore, flowers of species from section Klanderia have red corolla pigments which may be masked by other pigments. The corollas of section Prostanthera usually contain blue pigments with colour variation being the result of masking by additional pigments or by the possible lack of pigmentation.

The inner surface of the corolla (in sect. Klanderia) is usually paler than the outer surface. Frequently, the inner surface has a yellow or cream-coloured tinge (e.g. in P. florifera, P. aspalathoides). Dark, more or less maroon dots or streaks are frequently present on the distal part of the inner surface of the tube, the mouth and the abaxial median lobe.

Androecium: The flowers are protandrous (typical of most Labiatae, van der Pijl 1972), with 4 epipetalous stamens located between the abaxial and lateral lobes, and between the adaxial lobe-pair and the lateral lobes.

They are inserted approximately 8 to 10 mm above the base of the corolla. The stamens are didynamous, with the two abaxial ('lower') ones longer than the two adaxial ('upper') ones.

The filaments are more or less ligulate and 5 to 8 mm long. They are basally curved towards the adaxial surface of the corolla and then extended forward, lying next to the inner adaxial surface of the corolla. The filaments are glabrous, but triangular glandular trichomes are frequently present.

The basifixed anthers are tetrasporangiate and bilocular (sensu Green 1980). The basal lobes of the anthers are obtuse or shortly acuminate. Triangular trichomes are frequently present on these lobes. In P. florifera, P. grylloana, P. laricoides, P. patens and P. serpyllifolia ssp. microphylla, the connective is extended to form a short appendage. In P. aspalathoides and P. chlorantha, the appendage is usually minute (mostly less than 0.3 mm long) and so, frequently appears absent. The appendage usually has a few triangular trichomes, particularly at or near the apex. The anthers are mostly obtuse to slightly emarginate apically. Dehiscence is introrse by longitudinal slits. Further details on how dehiscence is actually affected is discussed in the chapter on Pollination.

The anthers are held within the corolla, just short of the apex of the adaxial lobe-pair, and therefore, in effect are not exerted or if so, then only partially. The two abaxial anthers are distal to the adaxial pair (Fig. 53). Laterally, one abaxial and one adaxial anther are juxtaposed (Fig. 53B). The two abaxial anthers are positioned such that the ventral surfaces (dehiscence zone) of each are in contact (Figs 53 & 56F). The adaxial pair is similarly arranged. The stomium of each anther remains in contact with its opposite equivalent until dehiscence is completed.

The distal abaxial pair matures first and so, usually completes dehiscence before the adaxial pair. Once dehiscence is completed the stamens separate and relocate (separately) next to the inner surface of the abaxial parts of the corolla tube. This is illustrated in figure 52A-C, for section Prostanthera. At this stage, the anthers are often exerted between the lateral and abaxial corolla lobes.

Disc and Gynoecium: The more or less cylindrical disc is usually 0.5 to 1 mm long. The 2-carpellate gynoecium, which is distal to the disc, is superior, glabrous, and 20 to 30 mm long. The 2 locules of the ovary are further divided by a false septum, so that the ovary appears to be 4-loculate (Briquet 1895; Cronquist 1968, 1981; Sharma & Singh 1982).

The ovary is 4-lobed and, although the style is frequently regarded as gynobasic (e.g. Beadle et al. 1976; Haegi 1981; for further references refer Carrick 1977, p. 119), it is terminal (Junell 1934; Hutchinson 1969; Hickey & King 1981; Cronquist 1981). This arrangement is found in the Prostantheroideae and in Ajuga (Ajugoideae) (following system of Briquet 1895). All other subfamilies of the Labiatae are usually regarded as having the typical gynobasic style (refer Briquet 1895, Junell 1934, Weberling 1981). However, Sharma & Singh (1982) have shown that although the style appears to be gynobasic in the Labiatae, it is the rapid growth of the four ovary lobes which result in the style becoming deeply sunken in between these lobes. The distal lobing of the ovary is often obscure, especially when the ovules abort. Although the placentae appear axile, Sharma & Singh (1982) have shown that the Labiatae have a 'placentation which is neither true axile nor true parietal, but [is] an intermediate condition between the two'. The septum development is typical of that found in flowers with axile placentation, except that the two placental ridges arise from the inner lateral walls of the ovary (at the fused margin of the two carpels), which is typical of parietal placentation. The ovules are anatropous, laterally to sub-basally attached on their ventral surface, two per

carpel (appearing solitary because of false-septum), unitegmic and tenuinucellate (which is characteristic of the Labiatae, refer Corner 1976; Sharma & Singh 1982). The stigma is shortly bifid distally.

The various features of the gynoecium appear to be of no taxonomic importance since they are relatively invariable throughout section Klanderia.

Fruit and Seeds: The schizocarpic fruit is heteromericarpous (Roth 1977), comprising 4(1-seeded) mericarps [nutlets] (Figs 64E, 71E, 75E). Winkler (1939, 1940) regards the fruits of the Labiatae as foraminose (perforated by large hole) capsules since the mericarp ('Klausen') correspond to parts of the capsule wall which separates from the remaining carpel parts by a ring-shaped cleft. This type of separation involves tissue of the median part of the capsule - one of Stopp's (1950a, 1950b) three types of foraminose capsule types. As the seeds develop, the distal lobes of the fruit (formerly those of the ovary) enlarge. The seeds are enclosed in pericarp and the seed coat is reduced to the outer integument. As pointed out by Corner (1976), the seed-coat has little structure and so is 'almost negligible'. The endosperm is cellular and oily.

A comprehensive anatomical study of the fruits of the Labiatae was carried out by Wagner (1914; as summarized by Roth 1977). He found that the structural features of the pericarp were of taxonomic use in distinguishing certain genera of the Labiatae. Wojciechowska (1958, 1961a, 1961b, 1966) used morphological and anatomical features, particularly of the sclerenchymatous layer of the pericarp, to distinguish between the fruits of a number of European Labiatae genera. Within section Klanderia, macromorphological features of the fruits and seeds appear to be of little taxonomic value because they are relatively invariable.

POLLINATION AND FLORAL BIOLOGY

Introduction

Proctor & Yeo (1973) and, in particular, Faegri & van der Pijl (1979) provide brief reviews of the literature which discusses pollination in the Labiatae. The various concepts (e.g. pollination syndromes and blossom types) are mostly based on northern hemisphere species. Neither book mentions Prostanthera or the other genera of the Prostantheroideae. The only publication on pollination in the Prostantheroideae was by Keighery (in Armstrong et al. 1982) (refer p. 29). Since very little information has been published on the breeding systems, pollination mechanisms and pollinators of Prostanthera, our understanding is incomplete. The extent of our knowledge, which is mostly very superficial, is summarized in this chapter.

Field Observations

I have observed the Crescent Honeyeater (Phylidonyris pyrrhoptera) visiting flowers of P. walteri (sect. Klanderia) and unidentified honeyeaters visiting P. florifera and P. monticola (both sect. Klanderia). Keighery (1980) recorded three bird pollinated Prostanthera species from the South West Botanical Province (Beard 1980) of Western Australia. However, the method used for determining actual pollination from mere visitation is not given. He (Keighery, in litt.) has recorded White-fronted Honeyeaters (Phylidonyris albifrons), Brown Honeyeaters (Lichmera indistincta) and White-eared Honeyeaters (Lichenostomus leucotis) visiting P. aspalathoides [the locality suggests that this species is P. incurvata], P. grylloana and P. microphylla (= P. serpyllifolia ssp. microphylla); Singing Honeyeaters (Lichenostomus virescens) visiting the first two Prostanthera species; Purple-gaped Honeyeaters (Lichenostomus cratitius) visiting P. grylloana; and Western Spinebills (Acanthorhynchus superciliosus), Tawny-crowned Honeyeaters (Phylidonyris melanops) and Red Wattle-

birds (Anthochaera carunculata) visiting P. microphylla (= P. serpyllifolia ssp. microphylla). The only other published report was by Ford et al. (1979), who recorded bird pollination (at least in one species) in the Labiatae. Ford (in litt.) verified that Black-eared Miners (Manorina melanotis), Purple-gaped Honeyeaters and White-fronted Honeyeaters have been observed feeding on the nectar of the flowers of P. aspalathoides (sect. Klanderia). He also collected probable Prostanthera pollen from two Purple-gaped Honeyeaters, one Singing Honeyeater and one Tawny-crowned Honeyeater, from Monarto, South Australia (Ford, in litt.).

I have observed bees visiting flowers of P. behriana, P. lasianthos, P. ovalifolia, P. rotundifolia and P. striatiflora (all sect. Prostanthera). Keighery (1980) recorded eleven insect pollinated Prostanthera species, two of which, P. eckersleyana and P. wilkeana (both sect. Prostanthera), were visited by bees and wasps (Keighery, in litt.).

The structural floral differences between the flowers of the two sections (Figs 52 & 53) strongly reflect the presumed pollen vectors. Although the pollen vectors appear to be different for each section, the actual mechanism of pollination is thought to be probably very similar throughout the genus.

Pollination mechanism in section Klanderia: Birds feed on the nectar produced by the disc, at the base of the gynoecium. As the beak and part of the forehead of the bird enter the flower, the staminal filaments are displaced laterally. This also causes the anthers to be laterally displaced, thus exposing the pollen within the locules. As the bird's beak and forehead brush past the exposed pollen, which is slightly sticky, the pollen is transferred to the bird's beak. When the bird withdraws from the flower the anthers return to their initial position with the dehiscence zones in contact. The lateral displacement of the anthers (hence filaments) is achieved in two ways. Firstly, the corolla mouth is usually

narrowest between the lateral lobes. Therefore, the pollen vector comes in contact with the lateral parts of the corolla. This lateral distortion of the corolla actually shortens the distance between the abaxial and adaxial lobes. This shortening brings the anthers into closer contact with the pollen vector. Secondly, this lateral displacement of the anthers is also achieved by the presence of an anther appendage(s) (for examples, refer p. 23). The appendage is more or less orthogonal to the shortest axis of the corolla mouth. This ensures that the pollen vector will laterally displace these appendages (and hence, the anthers) while probing the flower for nectar. Triangular trichomes are frequently present on the more distal parts of the filaments and on the basal lobes of the anthers. These trichomes probably improve the contact between the stamens and the pollen vector. It is envisaged that this may assist in the dislodgement of the pollen from the locules and so, may result in improved pollen transfer. A similar mechanism was found in Dicerandra (Labiatae) from the southern United States of America by Huck (1981). She suggested that the anther appendages (spurs) in this genus (particularly those of D. odoratissima which show many similarities to those of Prostanthera) ensure an efficient transfer of pollen.

Pollination mechanism in section Prostanthera: The main floral structural difference between this section and sect. Klanderia is that the flowers of sect. Prostanthera have the shortest axis of the corolla mouth between the abaxial and adaxial lobes, not between the lateral lobes. There is still some lateral distortion of the corolla as the pollen vector enters the flower (particularly with Honey bees). However, further comment at this stage would be premature, since more detailed observations are necessary.

Floral biology and ornithophily in section Klanderia: Faegri & van der Pijl (1979) have summarized the typical ornithophilous syndrome (also refer Proctor & Yeo 1973). In general, the flowers of the species in

section Klanderia have characteristics comparable to those of typical ornithophilous species. These characteristics include: a relatively strong corolla which is more or less tubular (Fig. 53); the lack of floral scent; abundant nectar; the displacement of anthers and stigma from the nectary; the corolla's lacking a landing stage; and the basic colour of the corolla's being red.

According to Faegri & van der Pijl's (1979) classification system of blossom types (pollination units), Prostanthera (in fact, most of the Labiatae) have a gullet-shaped blossom (Faegri & van der Pijl 1979, p. 89 - I.2.D., - Fig. 49). Keighery (in Armstrong et al. 1982) lists 4 genera of the Prostantheroideae which he regards as having gullet-shaped blossom. In this type of corolla, the androecium, style and stigma (of the gynoecium) are 'restricted to the upper [adaxial] side of the "pollination unit" and pollen is deposited nototribically, on the vector's head' (Armstrong 1979). Although the flowers normally hang down, except in more or less prostrate forms where the corolla mouth is directed upwards (e.g. P. serpyllifolia at Innes National Park on exposed limestone cliffs, P. walteri on exposed sites), the birds have no difficulty perching (often upside down) on the distal branches while probing the flowers for nectar. The slightly sticky pollen found in flowers of this section, which adheres to the bird's beak, is typical of ornithophilous flowers (Ford et al. 1979).

Those flowers which have greenish corollas frequently have calyces which have, at least distally, a red-purple tinge. Therefore, this red-purple tinge may compensate for any effects caused by the masking of the red corolla pigments by contrasting the flower against the green foliage. At least to the human eye, a calyx with a purple tinge is almost as obvious against the green background of the foliage as is a red corolla. This contrast between red (including purple) and green is quite effective and is common in a number of groups. A similar contrast was noted by Conn (1980), with respect to seed dispersal in Geniostoma (Loganiaceae).

Raven (1972) pointed out that red and orange colours are not conspicuous to insects, except possibly butterflies. Therefore, flowers of these colours would blend with the green foliage. Furthermore, even if abundant carotenoids are present (as in many orange flowers), their ultraviolet reflectivity (which is conspicuous to insects) is partially, if not totally masked by the red anthocyanins of the same flowers (Raven 1972). However, red and orange are at least as conspicuous to birds as they are to humans (Knoll 1956; Faegri & van der Pijl 1979), if not more so (Gottsberger 1971).

Several studies (e.g. Grant & Grant 1968) have shown that birds do not necessarily appear to have an intrinsic preference for red, but it is thought that they learn to associate this flower colour with the high caloric rewards of the nectar (Raven 1972). Typical of ornithophilous flowers, those of section Klanderia are scentless. Since insects are attracted by odour (Faegri & van der Pijl 1979), they are not aware of the nectar rewards provided by these scentless flowers.

Ford et al. (1979) discuss the possible advantages of ornithophily with respect to pollination efficiency, and other related aspects. For instance, they point out that birds can carry more pollen than insects, and so, can pollinate more flowers. They suggest that the production of fewer flowers may be a response which compensates for the increased energy required to produce larger, stronger flowers with greater quantities of nectar. The increased nectar supply being required to adequately provide for the higher energy requirements of birds (Ford & Paton 1976). Ford (in litt.) obtained an average nectar content/flower for P. aspalathoides (based on 6 flowers) of 8.7 μ l, with sugar concentrations of 28% by weight of sucrose equivalents. This relatively large quantity of nectar with a correspondingly high caloric content is typical of ornithophilous plants. For example, Pyke (1980) obtained an average sugar concentration for plants visited by honeyeaters of 20.4% by weight of sucrose equivalents, and

Ford (in Pyke 1980) obtained a value of 21.7%. Paton & Ford (1977) and Pyke (1980) have shown that plants frequented by honeyeaters have nectar with relatively high mean caloric content (overall average 8.4 calories per flower, Pyke 1980). The racemiform inflorescence (of sect. Klanderia) may be an adaptation to ornithophily. However, some species of section Prostanthera (e.g. P. spinosa) have a similarly reduced inflorescence. Ford et al. (1979) also suggest that birds visit more flowers (of a population) more frequently than do insects. Observations of birds visiting P. walteri and P. monticola (sect. Klanderia), compared with bees visiting P. striatiflora (sect. Prostanthera) support this. However, bees appeared to visit plants of P. lasianthos (sect. Prostanthera) (at Mt Ellery, Victoria) as frequently as the birds for P. walteri (also Mt Ellery). Unfortunately, no quantitative data are available, so a comparison is not possible. Although the relative efficiency of birds and insects as pollinators can be measured in terms of frequency of visits to flowers, frequency of visits to separate plants, amount of pollen carried, and so on, a consideration of the relative production of viable seeds would be necessary so that the actual effectiveness of each could be evaluated.

Breeding system in section Klanderia: In the absence of a more substantial body of information on the subject, a very preliminary and speculative summary is offered. Since the flowers are protandrous, with the stigma only receptive once the anthers have dehisced, species of section Klanderia appear to be essentially outbreeders. This is further ensured because the immature stigma lies between the apices of the anthers and the adaxial surface of the corolla ('above' the anthers). Furthermore, stylar elongation exserts the mature stigma beyond the adaxial corolla lobe-pair without making contact with the staminal dehiscence zones. Hence, the flowers are dichogamous and herkogamous. Therefore, there

appears to be no self-pollination mechanism within individual flowers. It seems likely that these ornithophilous species (of sect. Klanderia) are dependent for fertilization on visits from the pollen vector, since they lack self-pollination mechanisms within individual flowers. Whether or not flowers which have not been visited by pollen vectors are capable of producing viable seeds is not known. However, the developmental sequence of the racemiform inflorescence is such that flowers at all stages may be present on any individual plant. Therefore, geitonogamy is potentially possible. In P. walteri, birds were observed to visit open flowers, irrespective of maturity. Furthermore, the birds visited several flowers on the same bush before visiting flowers of another bush. Whether or not self-fertilization occurs depends on the level of self-compatibility, although protandry would give a slight advantage to out-breeding.

SEED DISPERSAL AND SEEDLING ESTABLISHMENT

Labiatae fruits are synaptospermous (all mericarps released as a whole) (Roth 1977). In section Klanderia the calyx and the pedicel (a_1 axis + anthopodium) remain attached to the fruit and so fall with the mericarps. Fruits which remain on the plants, after the majority have fallen, usually contain a significantly high number of aborted seeds.

The actual seed dispersal mechanism is not known. However, it seems likely that the mericarps fall directly to the ground with very little lateral displacement caused by air-currents.

Seedlings appear to be rare (in sect. Klanderia) and usually occur near the base of the parent plant. In P. behriana (sect. Prostanthera) (at Monarto South, South Australia), seedlings were only found amongst the dead branches (which lay on the ground). It is assumed that these seedlings were not grazed because they were protected by the tangle of branches. However, grazing by wallabies has been observed for P. spinosa (sect. Prostanthera) on Kangaroo Island, South Australia (refer Conn 1081 - 1084). The soft juvenile shoots of this species are heavily grazed, but the older shoots are protected by the hardened spines. Cunningham et al. (1982) note that P. aspalathoides and P. leichhardtii (= P. ringens) are not grazed by stock, but P. microphylla (= P. serpyllifolia ssp. microphylla) is only grazed when other feed is very limited. P. florifera appears to be grazed, probably by kangaroos and livestock. In general, more observations are necessary before the extent of grazing and its possible role, if any, in seed dispersal can be evaluated.

NUMERICAL ANALYSIS

Introduction

In numerical taxonomy, any biometric analysis which attempts to organize individuals into groups is regarded as classificatory. This aspect of classification which results in group formation is allied to the concept of dissection (Kendall & Stuart 1966), which is the 'splitting of a continuous into a discontinuous series' (Clifford & Stephenson 1975). Dagnelie (1966) also included a predictive (identification) concept into the meaning of classification. That is, once the dissection stage is completed, a new specimen could be allocated to one of a number of defined groups. If this new specimen should require the groups to be redefined, then the identification and dissection processes form an integral part of the classificatory process.

There are many aspects specific to numerical classification which are discussed in Williams (1971, 1976). These are not discussed here because they do not represent further differences from non-numeric concepts of classification. Lance & Williams (1967) list four types of classification, namely (i) clustering, (ii) clumping, (iii) dissection, and (iv) identification. They also include the simplification of the data by ordination as a type of classification. However, ordination does not necessarily lead to the recognition of groups within the sample being tested. The principal difference between classification and ordination is that the former is concerned with the organization of individuals into groups, whereas the latter is concerned with the relationship between the individuals. Prior to ordination, the individuals are located in a multidimensional space which is usually defined by some measure of their dissimilarity. Ordination expresses the relationship between the individuals by reducing the

dimensionality of the space while minimising the loss of information.

In classical (non-numerical) taxonomy, classification is regarded as being the grouping of organisms in such a way as to best reflect their total similarities and dissimilarities, and to describe the distributions among organisms of as many of their characters as possible. This concept is also a major aim of numerical taxonomists, but as yet, there is no single algorithm which can completely express the totality of these similarities and dissimilarities. Likewise, because of other limitations, in particular subjectivity, such a definition of classification is actually more of an aim than a reality for non-numerical taxonomists.

In non-numerical phenetics the individuals are arranged relative to their overall ('nett') similarity. One important feature of a non-numerical classification is that the discrete groups are arranged relative to each other after being assigned to a certain rank. In numerical phenetics, hierarchical classification (Williams 1971) presents a similar arrangement which can be readily expressed in two dimensions in the form of a phenogram. However, the individuals are arranged relative to a set of ultrametric distances which define the phenogram. These ultrametric distances are the transformed set of pair-wise dissimilarities (Sneath & Sokal 1973). McNeil (1978) clearly summarized the differences between non-numeric classification and phenograms as (i) classifications are rank-defined, whereas (ii) phenograms are distance-defined. The distance value of a phenogram is the 'actual fusion-level derived from the distance or dissimilarity being used' (McNeil 1978).

McNeil (1978) added to Farris' (1977) definition of classification that a 'phenetic classification should also have a predictive element'. This is similar to Dagnelie's (1966) identification concept for numerical

classification. Therefore, McNeil's definition is preferred since it is comparable to that used by most non-numerical taxonomists.

SELECTION OF MORPHOLOGICAL CHARACTERS

An estimate of resemblance between organisms is based on a consideration of as many features as possible of the individuals concerned. In classical taxonomy these features are usually known as taxonomic characters, while the literature of numerical taxonomy contains a number of terms (e.g. character, attribute, variable) which have been variously defined and hence, applied differently by different authors. The term character has been most commonly used as 'a property which differentiates a taxon of any rank from at least part of the taxa of the same rank which are all subordinated to the same taxon at the next higher level' (Leenhouts 1968). A similar definition was used by Mayr (1969). In this sense, characters are defined as the differences between taxa, but as pointed out by Sneath & Sokal (1973), 'the taxa cannot be recognized without the characters themselves being first known'. Therefore, this definition is inappropriate and so characters are not used in this sense, in this study.

Another frequent meaning of the term character is that it is 'anything [a property] that can be considered as a variable independent of any other thing considered at the same time' (Cain & Harrison 1958). It has been frequently used in this sense by numerical taxonomists (e.g. Michener & Sokal 1957; Sokal & Rohlf 1969). In this study, a definition similar to that of Cain and Harrison (1958) is used. That is, a character is regarded as 'any attribute (or descriptive phrase) referring to form, structure or behaviour which the taxonomist separates from the whole organism for a particular purpose such as comparison or interpretation' (Davis & Heywood

1963). Therefore, character is here used in a similar sense to that of attribute, as used by Clifford & Stephenson (1975), and Williams (in Williams 1976). Hence, character states are the expression or nature of the character concerned and are not used in the sense of Jardine (1969). Sokal and Sneath (1963) proposed the term unit character. Although the concept is possibly theoretically sound, it seems likely that division of characters into units will frequently be difficult. Therefore, as a working definition, the more general definition of Davis and Heywood's is preferred.

Pre-numerical analysis

Initially Prostanthera section Klanderia was studied using classical (non-numerical) taxonomic procedures. The amount of herbarium material available for study was far too much to be taxonomically analysed as one unit. Hence, the material was initially sorted into broad geographical units. These units mostly corresponded with State boundaries, although more natural geographical units such as mountains, mountain ranges and islands were also used. Each unit was of a more manageable size than the unsorted material since (within each unit) there are fewer taxa to be dealt with or, in the case of widespread species, less variation than expressed over its entire area of distribution. Within each unit duplicates and population collections were grouped together so that a more reliable impression of the morphological variation within either individuals or populations could be achieved. Finally, entities (specimens or populations) which showed a strong mutual gross morphological resemblance were grouped together. Entities which appeared intermediate between any two groups were kept separate and were carefully compared with each group at a later stage. Many of these intermediate entities occurred near State

boundaries of what proved to be more widespread species (e.g. P. aspalathoides). Several of the groups formed as a result of the above sorting proved to be morphologically homogeneous within each group, as well as morphologically distinct from the other groups. These groups are recognized as distinct species (viz. P. chlorantha, P. florifera, P. grylloana, P. monticola, P. ringens and P. walteri). For detailed descriptions and notes on the diagnostic features of each of these species refer to the relevant parts of the 'Systematic Treatment'.

The choice of characters and the final character set used are discussed on pp. 39-40 and Table 1. With the exception of those characters involving density of hairs and glands, all characters listed in Table 1 were used in this non-numerical taxonomic analysis and so form the basis of the botanical descriptions.

The remaining (less homogeneous) groups, including P. florifera (refer Fig. 5 for locality of groups) were analysed in more detail by numerical techniques (refer pp. 51-81). These largely arbitrary groups were used to evaluate the character set (pp. 40-51) and to evaluate the suitability of these groups as classificatory units (pp. 51-64). The modified classification which arose out of these analyses (p. 61) resulted in three species complexes being recognized (viz. P. aspalathoides, P. calycina-P. microphylla-P. serpyllifolia, and P. laricoides). The morphological structure of each of these was then analysed in further detail (pp. 65-81).

Method used to select morphological characters

During the initial classical taxonomic analysis of sect. Klanderia a general overview of this section was obtained and various taxonomic problems were located. In addition to this, characters were evaluated for their taxonomic usefulness based on knowledge gained from my preliminary taxonomic investigation of this section.

The selection of characters (for both the numerical and non-numerical analyses) was based on a number of criteria. Most importantly, the only characters used were those which could be consistently measured so as to represent unambiguously the relevant feature. It was found that corollas could not be measured so as to represent consistently and accurately the true shape. There are a number of factors which determine the ultimate corolla shape, particularly in herbarium material. Maturity and position of the corolla, relative to the foliage and branches, are two of the most important factors which may lead to changes of the corolla shape. The extent of recurvature of the corolla lobes is also a factor which determines the overall shape of the corolla. It was not possible, without ambiguity, to measure accurately the extent of this recurvature. Furthermore, this feature appears to be correlated with anthesis and fertilization. Therefore, the taxonomic usefulness of this feature is diminished because it is difficult to accurately determine the maturity of the flower. The problems that I have encountered in trying to use the various aspects of corolla shape as taxonomic characters, commonly occur in many groups which have bilabiate corollas. Ideally, fresh material which has been grown under controlled conditions is necessary. Although many collections were specifically made for this study (alcohol preserved material being available for most of these), intensive collecting would have been necessary to ensure that suitably preserved corollas would be available for a much larger data set. Unfortunately, this was not feasible during this study.

Since I was in part relying on herbarium material, of which some was not collected specifically for this study, I chose characters which were present on most of the collections. Finally, I avoided characters which appeared to be invariable (e.g. those of fruits, hence mericarps;

those of seeds; and magnitude measurements of corolla tube, mouth and lobes). The invariability of such characters was determined by measuring selected specimens from different taxa.

Of the characters which could be accurately measured, it was found that some of these were absent in some taxa whereas present in others. For example, some had glabrous branches, others were hairy; some had an anther appendage, others lacked this appendage. However, most of the differences between taxa were quantitative. For example, there were differences between taxa in the magnitude of the following features: lamina length, prophyll length, calyx length, anther appendage length, and pedicel length. There were also differences between taxa in the expression of the shape of various characters. These differences, which also have a magnitude component, have been evaluated as ratios. For example, length to width ratios of lamina, and prophyll; and the position of the maximum lamina width which was measured as the ratio of the distance the maximum width is from the lamina base to total lamina length. Differences in the size of one character relative to another was also evident between a number of taxa. For example, the ratio of the length of the calyx lobes to the length of the calyx tube, and the length of the petiole to the lamina length. It was also found, from my initial study, that the position of the prophylls on the pedicel (that is, the length of the a_1 axis), and the position of the hairs on the branches varied between many taxa.

Differences between the taxa were relatively obvious with respect to the above characters. However, the taxonomic importance of these differences was not always clear. The level of correspondence between the various character states and the different taxa was not known. For example, P. aspalathoides, P. microphylla and P. serpyllifolia are usually differentiated on the basis of the size and shape of the leaves, and the

presence or absence of an anther appendage. However, during my preliminary study it was noted that it was frequently difficult to classify certain specimens into any of these three taxa on the basis of leaf length or shape. Furthermore, specimens which appeared to belong to P. aspalathoides on leaf characteristics, had short anther appendages whereas other similar specimens lacked this appendage. Traditionally, P. microphylla (= P. serpyllifolia ssp. microphylla) is usually distinguished from P. aspalathoides, at least in part, by the former taxon having an anther appendage and the latter, supposedly lacking this appendage. Therefore, my preliminary study indicated that should a difference exist between these two taxa, with respect to the anther appendage, then it was more likely to be quantitative than qualitative.

The taxonomic importance of the various aspects of indumentum (glandular and eglandular) was more uncertain than most of the above characters. As mentioned before, there are differences between taxa with respect to the position of the hairs on the branches, and some taxa have glabrous branches whereas others were hairy. Similarly, differences in the shape of the hairs on the branches were of unknown importance. Therefore indumentum characters were included in the final character set so that they could be rigorously evaluated by biometrical techniques.

The raw data is not included because of its bulk, but it is available from the author on request. The morphological characters used are listed, with brief explanations in Table 1. The density of hairs and glands were measured using a glass ocular graticule. The number of hairs or glands in one millimetre square were counted and the average of five separate density measurements were used. The other features (refer Table 1) are self-explanatory and so will not be discussed further.

AAL	length of anther appendage (mm), if two appendages then length of longest appendage
BL	length of prophyll (mm)
BLW	length to width ratio of prophyll
INTER	position of hairs on branches - hairs absent (0), hairs on two opposite sides (1), hairs on all sides (2)
KGDO	density of glands on outer surface of calyx (number of glands/mm ²)
KHDI	density of hairs on inner surface of calyx (number of hairs/mm ²)
KHDO	density of hairs on outer surface of calyx (number of hairs/mm ²)
KL	length of calyx (mm)
KLLT	length of calyx lobes to length of calyx tube ratio
LGD	density of glands on leaf (number of glands/mm ²)
LHD	density of hairs on leaf (number of hairs/mm ²)
LKLP	position of prophyll on pedicel (anthopodium length divided by a ₁ axis) (see Fig. 2B)
LL	length of lamina (mm)

Table 1. Final character set used in the various biometrical analyses (continued on next page).

Table 1. Continued

LLW	ratio of lamina length to maximum width of lamina
LLWL	position of maximum width of lamina (distance maximum width of lamina from base divided by length of lamina)
LPLL	length of petiole to length of lamina ratio
PL	length of pedicel (mm) [anthopodium + a_1 axis] (see Fig. 2B)
STBB	length from base of hair to first bend of hair (mm). Hairs of branches measured
STGD	density of glands on branches (number of glands/mm ²)
STHD	density of hairs on branches (number of hairs/mm ²)
STHL	length of hairs on branches (mm)
STHW	basal width of hairs on branches (mm)
STMX	maximum distance any part of hair (of branches) is from surface of branch (mm)

Table 1. Final character set used in the various biometrical analyses.

Evaluation of character set

Since the characters used form the basis of the subsequent classification, these characters were critically evaluated for both their validity and their taxonomic value. The assessment of the characters included a consideration of the discriminatory 'power' (or uniqueness of the information content of each), the variability of each, and the extent of redundancy of information in the characters as a whole.

Initially, the fundamental distributional characteristics of the characters (of the individuals examined) were analysed (using subprogram CONDESCRIPTIVE, Nie et al. 1975) and some of the statistics are presented in Table 2. The significance of the deviation from normality of kurtosis and skewness were tested using the t-test (as modified by Sokal & Rohlf 1969). All characters were nonparametrically distributed. Therefore, statistical tests which assume normality were not used, except on transformed data (that is, data standardized by range, refer pp. 64 & 83).

Bivariate correlation analysis was used to evaluate the extent of the redundancy of information for each character. The nonparametric rank-order correlation coefficients of Kendall's tau were computed (using subprogram NONPAR CORR, Nie et al. 1975). Kendall's tau gives a measure of how similar any two characters are without making any assumptions about the distributional characteristics of the characters. The most common significance test is whether a sample correlation coefficient could have come from a population which has a correlation coefficient equal to zero (that is, $H_0 : \rho = 0$). A t-test with $n - 2$ degrees of freedom was used to test the hypothesis (refer Bailey 1959; Sokal & Rohlf 1969). Those pairs of characters with the highest correlation coefficients (those greater than 0.4 or less than -0.4, at the 0.001 significance level) are

CHARACTER	MEAN	RANGE	STANDARD ERROR (STANDARD DEVIATION OF MEAN)	STANDARD DEVIATION (VARIANCE)	KURTOSIS	SKEWNESS
INTER	1.77	0-2	0.02	0.50	3.49	-2.07
STHD	105.68	0-468.81	2.38	58.43	6.81	1.66
STGD	32.24	0-174.18	1.06	26.13	4.83	1.97
LPLL	0.06	0-0.52	0.003	0.07	2.44	1.16
LL	4.27	1-19	0.10	2.39	3.34	1.37
LLW	5.02	1-31.25	0.15	3.71	7.60	1.92
LLWL	0.48	0-4.33	0.01	0.30	56.17	4.95
LHD	18.22	0-486.09	1.39	34.18	88.77	7.85
IGD	42.57	1.89-230	1.13	27.76	11.76	2.75
PL	2.80	0.75-13	0.08	1.88	10.84	2.98
BL	2.56	0.5-5.25	0.03	0.63	1.57	0.23
BLW	5.26	1.6-11.67	0.06	1.40	1.49	0.51
LKLP	0.07	0-1.31	0.01	0.15	23.12	4.07
KL	7.43	3.95-13	0.06	1.37	1.19	0.87
KLLT	0.64	0.14-1.1	0.01	0.14	1.04	0.06
KHDO	15.38	0-219.28	1.13	27.82	16.41	3.38
KGDO	16.31	1.9-132.5	0.55	13.58	22.22	3.95
KHDI	10.15	0-533.89	2.02	49.61	47.14	6.42
AAL	0.36	0-2.5	0.02	0.38	2.53	1.38
STHW	0.31	0-0.11	0	0.01	3.51	0.19
STHL	0.21	0-0.53	0.01	0.09	1.77	0.55
STBB	0.09	0-0.47	0.01	0.05	9.94	1.51
STMX	0.12	0-0.74	0.01	0.06	20.87	2.25

Table 2. Various statistics of the complete character set. For explanation of the character abbreviations, refer Table 1.

presented in Table 3. No character pairs varied significantly from zero. Therefore, all characters appear to provide a high level of 'uniqueness' with respect to their information content.

The most variable characters are hair and glandular density of the branches, leaves and calyx (Table 2). The amount of variability and reliability of a character as a delimitator of taxa is usually assessed by the variance-ratio or F-test, which is an analysis of variance (refer Williams & Stephenson 1973; Stephenson et al. 1974). The F-test considers the ratio of the between-group variance to that of the within-group variance. However, since this test assumes that the within-group values are normally distributed, in most instances it was not used to evaluate

CHARACTER - PAIR	KENDALL'S TAU
INTER - KHDI	- 0.4834
LPLL - LLW	- 0.5498
LL - LLW	0.6359
LL - LHD	- 0.4054
BL - BLW	0.5029
STHW - STHL	0.4945
STHL - STBB	0.4374
STBB - STMX	0.5794

Table 3. Correlation coefficients for selected character-pairs. For explanation of character abbreviations, refer Table 1.

the taxonomic usefulness of the characters for the complete data. However, the F -test was used in the stepwise options of subprogram DISCRIMINANT (Klecka [& Tuccy], in Nie et al. 1975), as discussed below.

The selection of the characters giving the best separation of the groups was achieved by the use of WILKS and RAO stepwise methods of subprogram DISCRIMINANT (Klecka [& Tuccy], in Nie et al. 1975). In the above two stepwise methods, the independent characters are selected for inclusion into the Canonical variate analysis on the basis of their discriminating power. In the WILKS method, the selection criterion used to choose the characters is the overall multivariate F ratio for the test of differences among the group centroids (Klecka, in Nie et al. 1975). The character which maximises the F ratio also minimises Wilk's λ , which is a measure of group discrimination. In the RAO method, the final criterion used to choose characters for inclusion into the analysis is Rao's V , which is a generalized distance measure (Klecka, in Nie et al. 1975). The character which contributes the largest increase in V when added to the previous character is selected. Hence, WILKS takes into account the differences between the centroids and the homogeneity of the groups, whereas RAO emphasises the greatest separation of the groups. Once the first character is selected, on the basis of one of the above selection criteria, the next character with the next highest selection value is chosen. This selection process continues until all characters are selected, unless stopped by limits applied by the user or default limits of the program (refer Klecka, in Nie et al. 1975, for further details).

The results of both step-wise procedures are summarized in Table 4 (only the first 12 characters are presented). The discriminatory power of all characters (except LGD and BLW, which had 'F TO ENTER' values of 0.7019 and 0.7808, respectively) is high since Wilk's λ is low.

STEP NO.	CHARACTER ENTERED	F ratio	WILKS LAMBDA	RAO'S V	CHANGE IN RAO'S V
1	KHDI	86.5099	0.24295	1816.71	0.1E+04
2	LPLL	77.7913	0.06900	3303.99	0.1E+04
3	INTER	68.0464	0.02437	4775.13	0.1E+04
4	KGDO	52.6431	0.01436	5807.01	0.1E+04
5	KHDO	51.0544	0.00557	6760.21	953.1987
6	LKLP	46.1469	0.00295	7610.29	850.0809
7	KL	42.3132	0.00165	8162.18	551.8912
8	LLWL	38.0996	0.00111	8660.18	498.0020
9	AAL	34.8443	0.00076	9151.25	491.0680
10	STHL	32.1295	0.00054	9540.86	389.6039
11	KLLT	29.7643	0.00041	9896.58	355.7237
12	STMX	27.6719	0.00032	0.1E+05	235.0866

Table 4. Statistics of the first 12 characters selected by Canonical variate analysis (significance of Wilk's Lambda and change in Rao's V is 0.000). Refer Table 1 for explanation of character abbreviations.

The change in Rao's V indicates that the change in distance between group centroids is statistically significant. All characters were retained for further analyses (unless otherwise stated) because there was no obvious 'cut-off' point. Information concerning the first three extracted canonical variate functions is given in Table 5. Changes in Wilk's lambda (associated with the chi-square significance test) indicate that the characters being used have considerable discriminatory power, at least for the first three functions. The eigenvalues (a measure of the relative importance of the canonical variate function) indicate that the first three functions (in particular, function 1) are very important when considering the complete data set. The characters which contribute most to the first standardized canonical variate function are KHDI, KGDO, INTER, and LKLP (Table 6). However, all coefficients are relatively low and no single character or group of characters are obviously more important than the majority of other characters. Rather, a number of characters are collectively important discriminators in function 1. A similar trend was found in functions 2 and 3.

Principal component and principal factor analyses (using the various options of subprogram FACTOR, Kim, in Nie et al. 1975) were used to determine the contribution of each character to the overall variance of the character set. Those characters which contribute the least to the overall variance are the least efficient in delimiting taxa. Chatfield & Collins (1980), Clifford & Stephenson (1975), Harman (1968), Jardine & Sibson (1971), Kim (in Nie et al. 1975), and Sneath & Sokal (1973) discuss the theory and methods which are suitable for the various situations requiring Principal component and/or Principal factor analyses.

The PA2 method of subprogram FACTOR (Kim, in Nie et al. 1975) was used because it uses an iteration procedure for improving the estimates of

CANONICAL VARIATE FUNCTION	EIGENVALUE	% of VARIANCE	CANONICAL CORRELATION	WILKS LAMBDA	CHI-SQUARED	D.F.
1	6.81100	36.49	0.93379	0.00122	3906.0	400
2	4.21830	22.60	0.89909	0.00639	2943.6	361
3	2.44118	13.08	0.84226	0.02198	2223.7	324

Table 5. Statistics of the first three Canonical variate functions (significance of Wilk's Lambda is 0.000). Refer to Table 1 for explanation of character abbreviations.

CHARACTER	FUNCTION 1
KHDI	-0.63857
KGDO	-0.45391
INTER	0.44090
LKLP	-0.24470
STHW	0.14436
STHL	0.13829
LHD	0.12477
LPLL	0.11991
AAL	0.11476
LLW	0.07819
KLLT	0.07706
BL	-0.05880
STHD	0.05612

Table 6.- Standardized Canonical variate coefficients for function 1 of the 13 most important characters.

communality. Only those factors with eigenvalues > 1 were extracted (MINEIGEN = 1), since factors with eigenvalues less than 1 account for less of the total variance than does a single character. Option VARIMAX (of subprogram FACTOR) was used to maximise the contribution of the first factor. This option rotates the axes orthogonally. As there was no prior reason to assume that there was correlation between factors, this option (VARIMAX) was used rather than option OBLIQUE (which assumes that factors are correlated).

The first three axes (factors) of principal factor analysis account for 33% of the variance. Characters KHDI, LPLL and INTER loosely cluster in the plot of factor 1 versus factor 2 (not presented here). STHL, KLLT and STMX also loosely cluster on this same plot. However in general, there was very little clustering of characters on the three factors.

After consideration of the statistics from the various analyses (as discussed above) all characters were retained to form the final character set (Table 1). However characters STBB, STHL, STHW and STMX (all referring to features of the hairs on branches) were not used in analyses which included specimens with glabrous stems. All characters are numeric (= numeric attribute, Williams, in Williams 1976), except for INTER which is ordinal (= ordinal attribute, Williams, in Williams 1976).

Numerical analyses of specimens

A number of species (viz. P. chlorantha, P. florifera, P. grylloana, P. monticola, P. ringens, and P. walteri) were sufficiently distinct using non-numerical procedures that further detailed biometrical analyses of these taxa were not necessary. However, P. florifera was included in the initial biometrical analyses so that additional clarification of the distinctness of this species from P. aspalathoides could be achieved.

The complexes which were studied in detail included the following taxa (as circumscribed by Bentham 1870): P. aspalathoides s. lat. (incl. the P. laricoides complex of Western Australia), P. calycina, P. microphylla, and P. serpyllifolia. Initially the specimens (refer 'Appendix') were assigned (using non-numerical methods) to 23 groups. These groups were morphologically defined using a relatively 'narrow' concept, and they included a consideration of distribution. Therefore, the 23 groups were a reflection of apparent morphological similarity and, in most cases, approximately represented geographical regions (Fig. 5 and p.37). This initial classification was tested using canonical variate analysis.

Canonical variate analysis (also known as multiple discrimination analysis) is a statistical technique which is used to test the significance of the differences between the (a priori) groups of the classification over all characters. It is not a pattern analysis (as used by Williams & Gillard-1971) or a classificatory technique because it arises when a classification already exists. The objective of canonical variate analysis is to compute one or more linear combinations of the discriminating characters so as to produce one or more discriminant functions. For details of this function, which is the equation of a line passing through the cluster of points representing the groups, refer Sokal & Rohlf (1969). The mathematical theory of how the discriminant coefficients are derived can be found in Rao (1952), and more generally in Blackith & Reyment (1971), Cooley & Lohnes (1971), Nie et al. (1975), and Sneath & Sokal (1973). These weighting [discriminant] coefficients are derived so that within-group variance is minimal and conversely, between-group variance is maximal. Sneath (1964) criticized the validity of this type of character weighting. He pointed out that characters can not be weighted on the basis of their within-group constancy since it involves the a priori

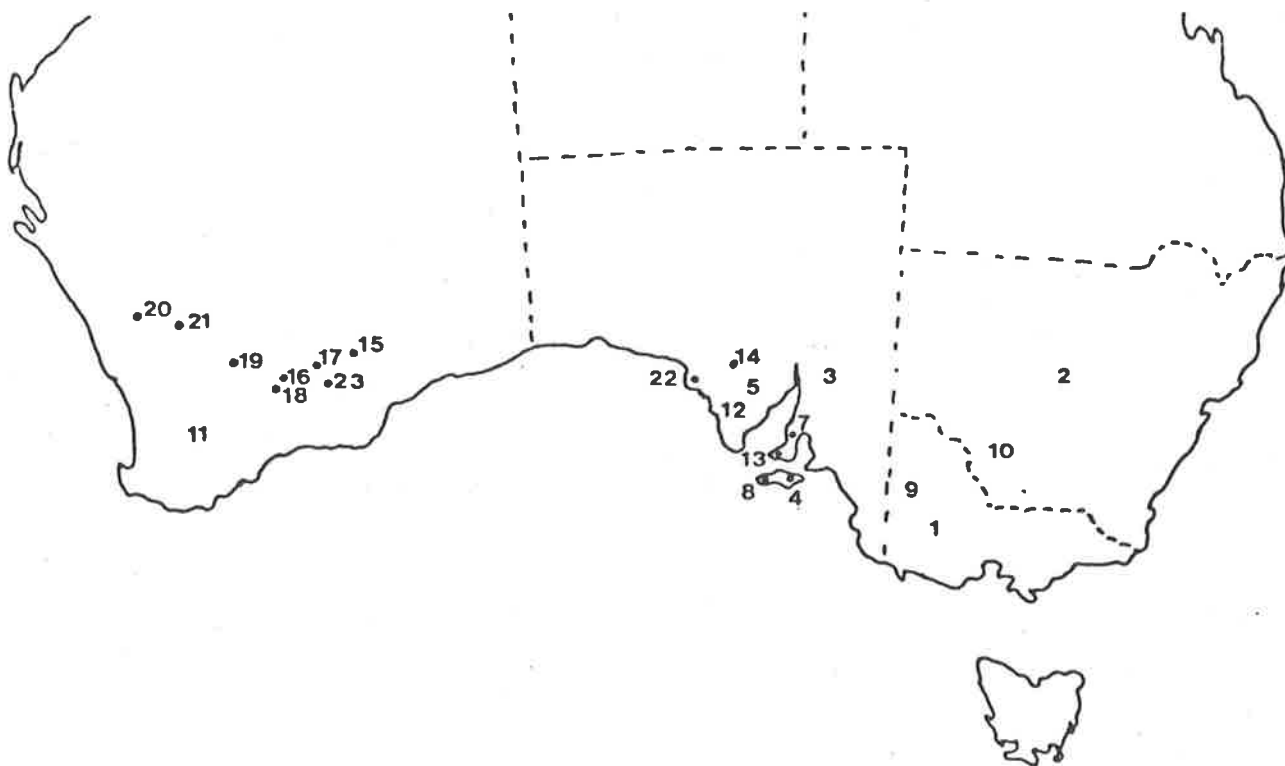


Fig. 5. Locality details of the 23 groups of the *P. aspalathoides*, *P. calycina* - *P. microphylla* - *P. serpyllifolia*, and *P. laricoides* complexes. Symbols are: *P. aspalathoides* - 1 = Victorian specimens, 2 = specimens from New South Wales, 3 = mainland South Australian specimens, 4 = Kangaroo Island specimens; '*P. microphylla*' - 5 = Eyre Peninsula specimens, 6 = Fleurieu Peninsula specimens, 7 = Yorke Peninsula specimens, 8 = Kangaroo Island specimens, 9 = Victorian specimens, 10 = specimens from New South Wales, 11 = Western Australian specimens; *P. serpyllifolia* - 12 = Eyre Peninsula specimens, 13 = Innes National Park specimens; 14 = *P. florifera*; 15 = *P. laricoides*; 16 = *P. semiteres*; 17 = *P. incurvata*; 18 & 19 = *P. semiteres*; 20 = *P. pedicellata*; 21 = *P. patens*; 22 = *P. calycina*; 23 = *P. incurvata*.

assumption of defined groups (cf. Leenhouts' definition of a character, refer p. 36). However, since it can be assumed that each of the replicate samples (of individuals or populations, refer p. 8) used in this study represent one taxon, these replicates provide a useful means by which the suitability of any classificatory technique can be checked. This technique for checking classifications has been used and recommended by several workers (e.g. Farris 1966; Sandland & Young 1979; Johnson 1982).

The discriminant functions are derived such that the first function has greatest ability to distinguish each of the groups. The second, third, and other remaining functions have progressively lower discriminating 'powers;. The resulting discriminant functions are better group-discriminators than any one character. This is particularly so when the distribution of the states of one or more characters overlap considerably (refer Sokal & Rohlf 1969, Fig. 14.24). The DIRECT method of subprogram DISCRIMINANT (Klecka [& Tuccy], in Nie et al. 1975), in which all characters presented are entered concurrently into the analysis, was used to test the initial classification.

The relationship between the groups, as expressed by canonical variate functions 1 and 2 is illustrated in the resulting scattergram (Fig. 6). The most striking feature of this scattergram is the separation of the Western Australian taxa (groups E - K & M) (Fig. 6) from the South Australian-eastern states taxa (with the exception of group A [from Western Australia] which is placed with the South Australian groups).

The four characters which contribute most to the first three canonical variate functions are given in Table 7. All the Western Australian taxa (excluding group A) have the inner surface of the calyx hairy. The analysis was repeated deleting character KHDI, to evaluate the import-

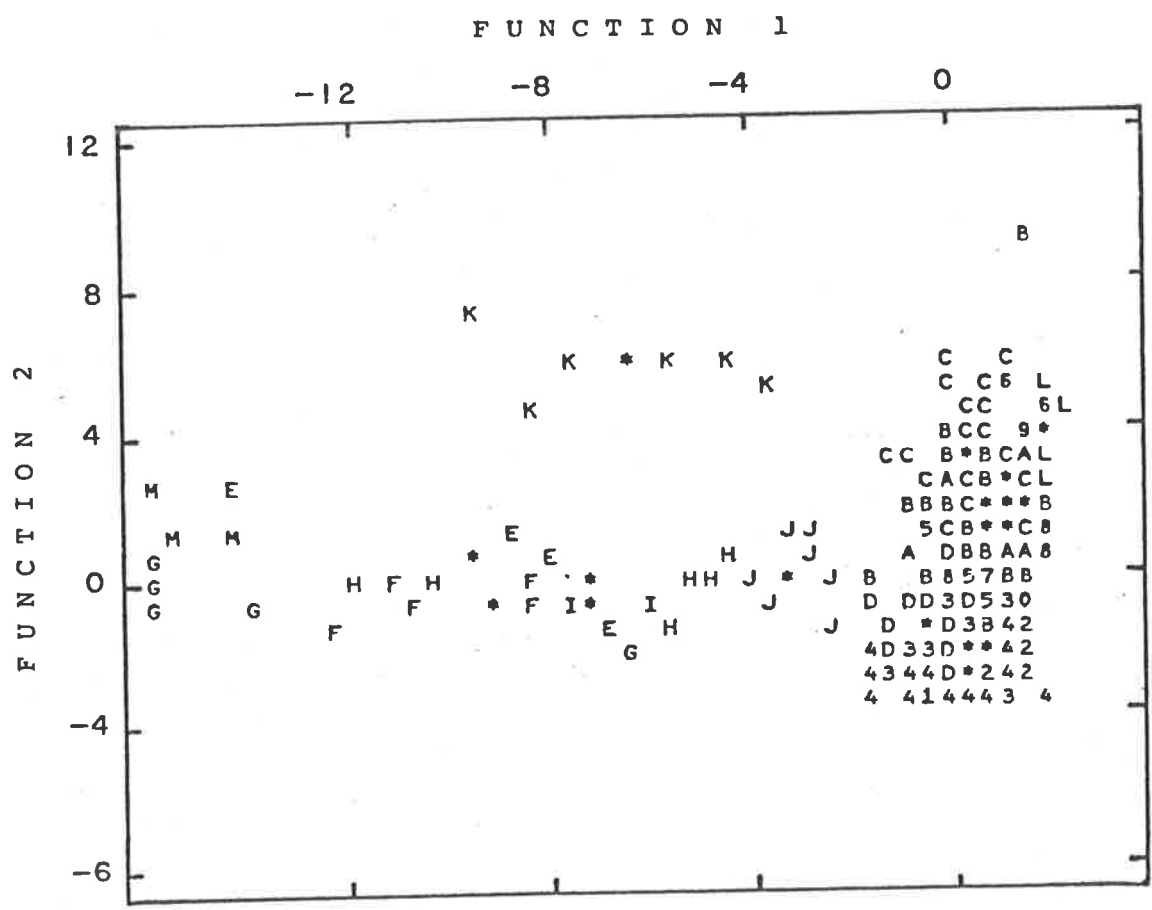


Fig. 6. Canonical variate scattergram (function 1 versus function 2) of the initial 23-groups of the *P. aspalathoides*, *P. calycina* - *P. microphylla* - *P. serpyllifolia*, and *P. laricoides* complexes. For details of taxa refer Fig. 3. 1 = 1; 2 = 2; 3 = 3; 4 = 4; 5 = 5; 6 = 6; 7 = 7; 8 = 8; 9 = 9; 0 = 10; A = 11; B = 12; C = 13; D = 14; E = 15; F = 16; G = 17; H = 18; I = 19; J = 20; K = 21; L = 22; M = 23; * = group centroid.

FUNCTION CHARACTER STANDARDIZED CANONICAL VARIATE
FUNCTION COEFFICIENT

1	KHDI	-0.76520
	KGDO	-0.41096
	INTER	0.33935
	LKLP	-0.16367
2	LPLL	0.71354
	AAL	0.37924
	LLWL	-0.33051
	STMX	-0.30192
3	KHDO	0.71665
	LKLP	0.59342
	KHDI	-0.22818
	KL	-0.19023

Table 7.- Standardized canonical variate function coefficients for the four most important characters, for the first three functions.

ance of this character in determining this division into two major groups. As can be seen from figure 7, this basic delimitation is maintained. The specimens of the Western Australian groups (groups E - K & M) (Figs 6 & 7) have tended to separate into several clusters. The remaining specimens have also tended to form several clusters. However, these groups are not resolvable into clearly separable clusters (at least on the first two functions) because of scaling limitations. Therefore, the infrastructure of these groups is dealt with separately so as to improve resolution. However, a simplification of the infrastructure was achieved by a consideration of the canonical variate [discriminant] distances between group centroids. A modification of the original computer program DISCD (written by P. Lang, Adelaide University) was used to compute euclidean distances in D-space between all pairs of group centroids (using the canonical variate functions for group means). The length of the line between any two centroids (measured in discriminant units) being equal to the square root of Mahalanobis' D^2 . The nearest-neighbour phenogram (modification of 'Single linkage clustering' of Florek et al. 1951a, 1951b; and Sneath 1957) (Fig. 8) which was generated from the canonical variate distance matrix, summarizes the distances between the various group centroids. The advantage of the computed distance metric is that it is a summation of all the character differences, whereas the canonical variates are only concerned with characters which distinguish groups. The most serious limitation of this phenogram is that the distances are based on the means of the various groups when the critical delimitation of complexes should take into consideration the 'boundary' and extent of overlap (if relevant) between the various taxa. It must be remembered that distances based on group centroids could be potentially misleading because they may over-emphasize the distinctness of groups. However, the nearest-neighbour

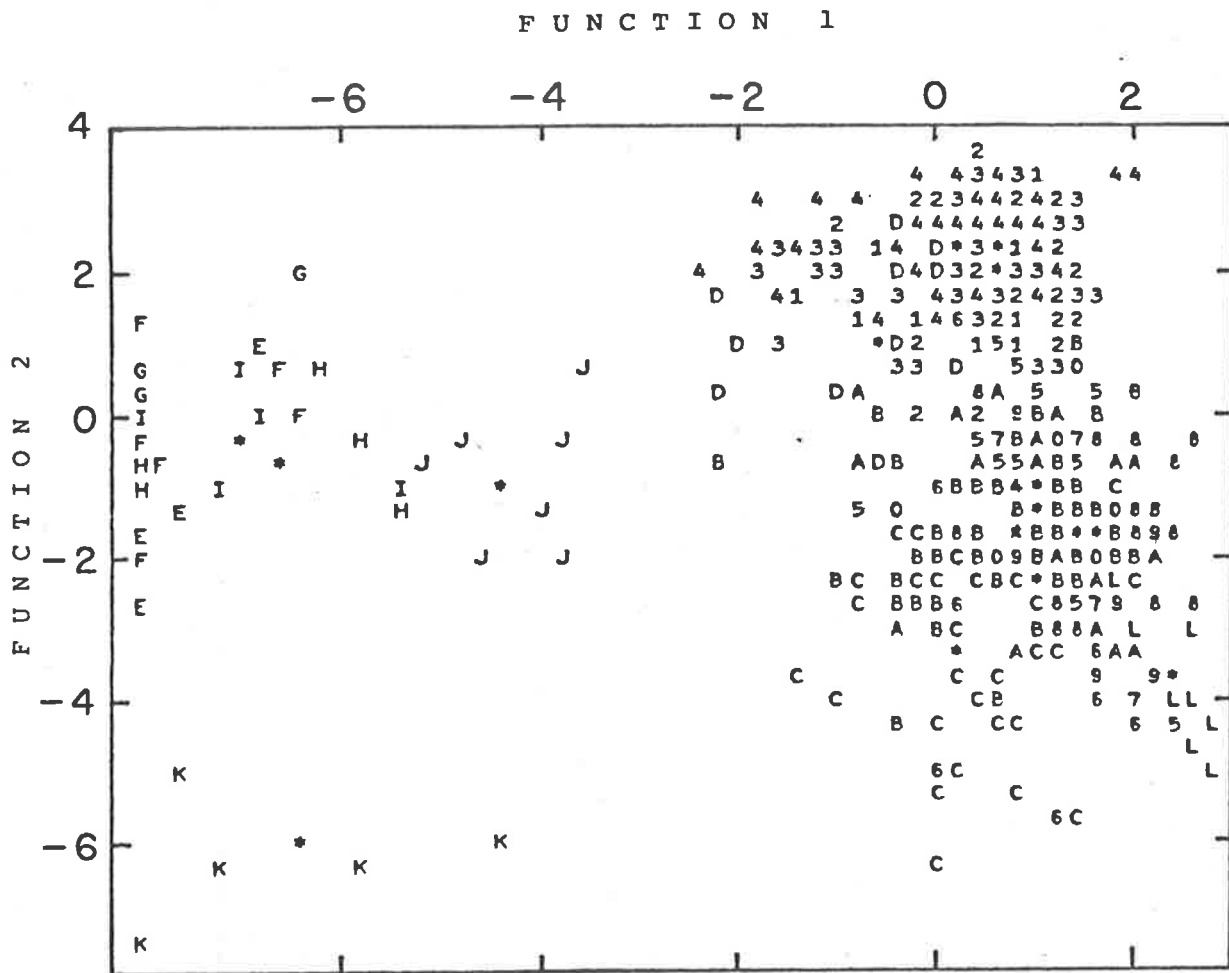


Fig. 7. Canonical variate scattergram (function 1 versus function 2) of 22 groups of the *P. aspalathoides*, *P. calycina* - *P. microphylla* - *P. serpyllifolia*, and *P. laricoides* complexes with KHD1 character deleted from the analysis. For details of the taxa refer to Figs 5 & 6, however note in this figure that groups 17 and 23 are collectively designated by the letter 'G'.

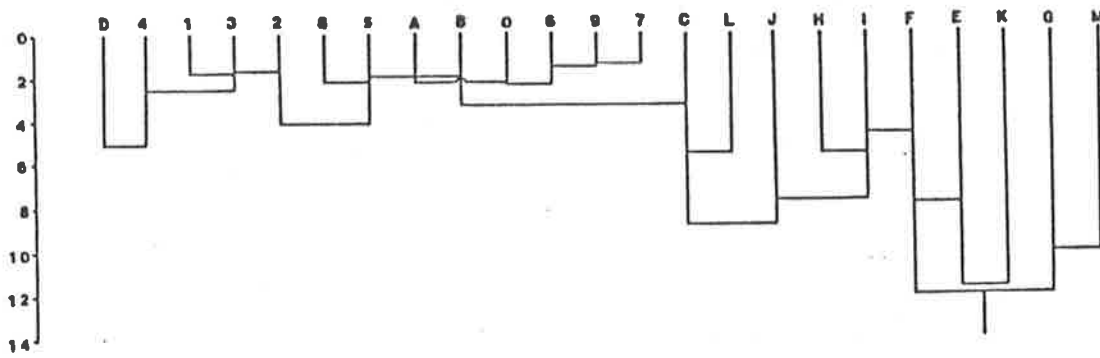


Fig. 8. Nearest neighbour phenogram generated from the Canonical variate distance matrix of the initial 23 groups. For details of the taxa refer to Figs 5 & 6.

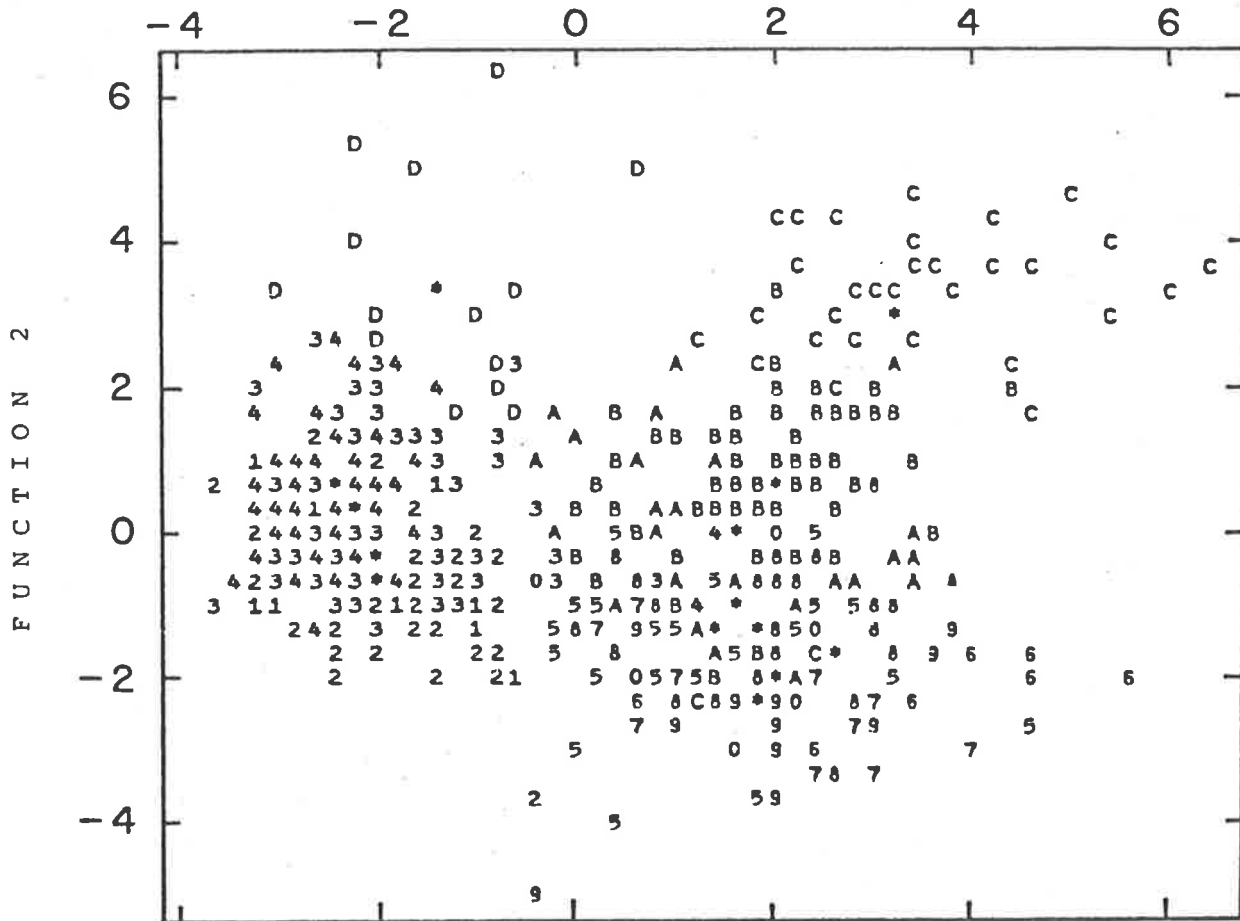
phenogram does assist in the interpretation of the canonical variate scattergram.

The determination of the number of taxa which should be recognized in a distance (dissimilarity) based phenogram is a major problem in numerical taxonomy. Sokal & Sneath (1963) advocated the use of a phenon line which was drawn across the phenogram at a particular percentage of similarity. They nominated all groups produced by that line as phenons. Unfortunately, the relationship between phenons and taxa is frequently rather obscure. However, one of the most serious objections to this technique is that, without some prior understanding of the taxonomy of the group being investigated, there is no way to predict where the phenon lines should be placed. Furthermore, unless the fusion strategy used is strictly space conserving, the drawing of phenon lines is invalid due to group-size dependence (Clifford & Williams 1973; Clifford, in Williams 1976). Ratkowsky & Lance (1978), using the Cramér measure (Cramér 1946) for the degree of association, developed a criterion for determining the 'optimum' number of groups in a phenogram without requiring prior knowledge of the taxonomy of the specimens concerned. However, they still required the application of the phenon line to determine the groups for which the Cramér measure is calculated. Hill (1981) modified the Ratkowsky & Lance criterion so as to overcome the invalid use of phenon lines. Although Hill's modification appears to improve the estimation of the number of groups in a phenogram, his criterion was unable to distinguish the specimens of Pittosporum rhombifolium (Pittosporaceae) from Tristania conferta (Myrtaceae) (refer Hill 1980), two unrelated taxa. Therefore, it seems doubtful that his criterion would be of any value when dealing with closely related taxa, as found in species complexes. Neither criteria were used to determine the number of taxa. Rather, the classif-

ication of replicate samples (as used by Sandland & Young 1979; Johnson 1982) was used to subjectively decide the number of taxa which should be recognized.

Based on distances, the Western Australian groups (excl. group A) remain distinct from the other groups (Fig. 8). Furthermore, the relatively distinct clusters within the Western Australian specimens (Fig. 6) are supported by the relatively large distances between the centroids of these groups (Fig. 8). The homogeneity of the other groups (Fig. 6) is verified by the variance of distance values being quite low, as shown in figure 8. However, the structure of the groups is clearer in the phenogram (Fig. 8). Groups 1 - 4 are very similar to each other and, on the basis of nearest-neighbour distances, appear to represent one taxon (P. aspalathoides) (Fig. 8). This is also supported, but less clearly by the canonical variate scattergram (Fig. 6). Group D (P. florifera) is most similar to P. aspalathoides (groups 1 - 4) (Fig. 6), however, the former appears to be a distinct taxon on the basis of the nearest-neighbour distances (Fig. 8). Groups 5 - B and possibly C appear to represent another taxon (P. serpyllifolia), whereas group L (P. calycina) is quite distinct from the previous groups on the basis of distance values. The distinctness of groups 1 - 4 from groups 5 - C was also evaluated using canonical variate analysis by (1) only including specimens of groups 1 - D (Fig. 9), and by (2) only including specimens of groups 1 - 8 (Fig. 10). The increased scaling improved the resolution such that groups 1 - 4 (P. aspalathoides) is regarded as distinct from groups 5 - C (P. serpyllifolia) (particularly evident in Fig. 10), and that group D (P. florifera) is a distinct taxon (particularly evident in Figs 6 & 7, also refer p. 205). The Western Australian groups (excl. group A) represented a distinct entity (refer Figs 6 & 8) which was studied in more detail (see below).

FUNCTION 1



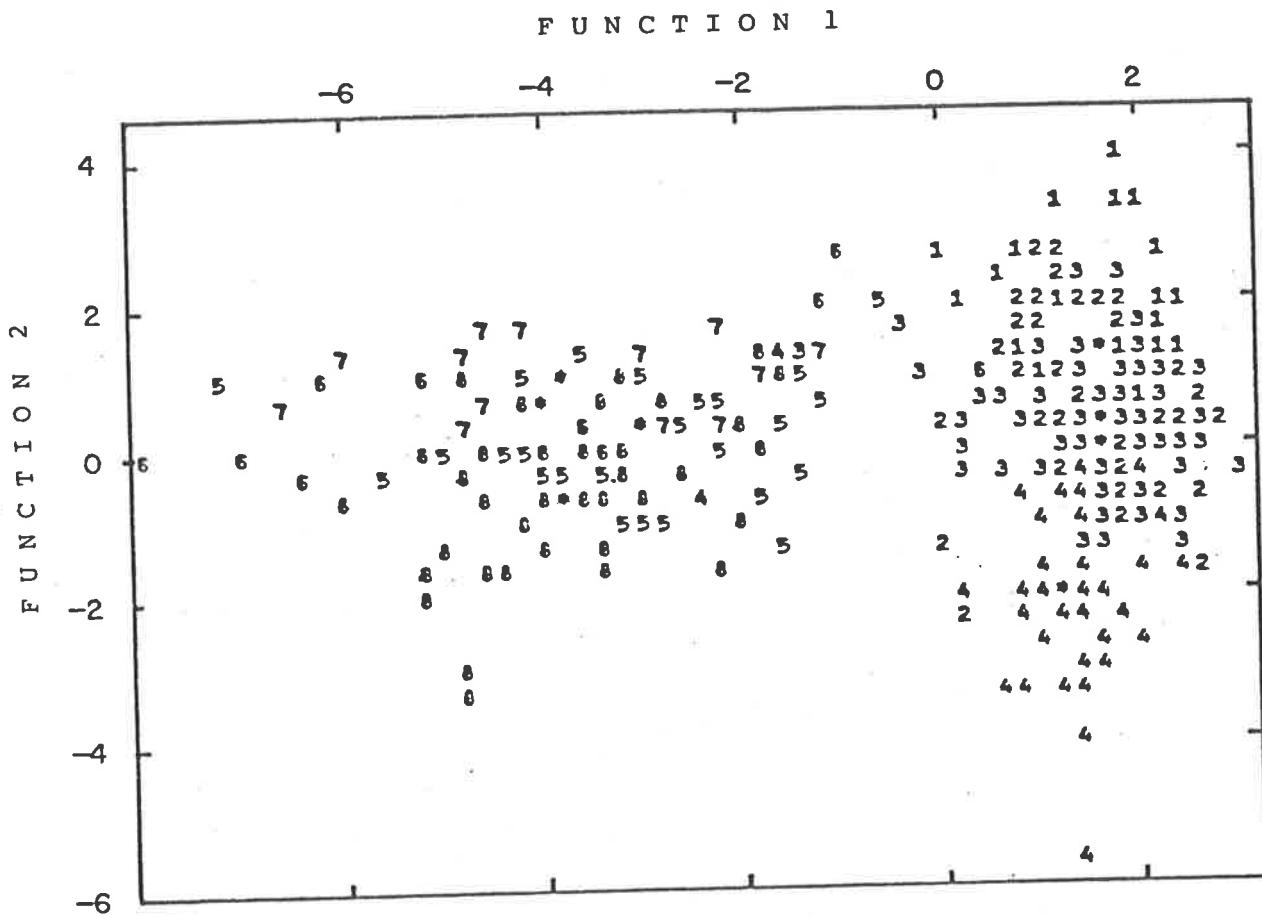


Fig. 10. Canonical variate scattergram (function 1 versus function 2) of the first eight taxa (Taxa 1 to 8). For details of the taxa refer to Figs 5 & 6.

Scattergrams of functions 1 and 3 (not presented here) further supported the distinctness of the above groups.

A number of computer programs were used in the following detailed analyses of the morphological variation within each of the above species and species complexes. Some of these programs have been discussed in the previous section (e.g. those used for canonical variate analysis and principal component analysis).

The data (of the original 23 characters) were standardized by range ($0 \leq \text{character state} \leq 1$) so as to minimise the effect of isolated strongly deviant values. The population means for each character were weighted by the $F-1$ value (Adams 1975). All characters with F values less than 1 (at the 0.01 level) were not used in subsequent analyses.

A matrix of Manhattan metric distances was calculated between the individuals [using program TAXDT (refer Whiffin 1978), which utilizes the $d_1(j, k)$ formulation of Sneath and Sokal 1973]. Williams and Clifford (in Williams 1976) showed that the Manhattan metric measure, using range-standardized data, is less affected by 'out-lying' values than some other measures (e.g. Bray-Curtis measure). This matrix was then used to group the populations, using the overall similarity of the individual specimens, in the form of hierarchic non-overlapping clusters. This was graphically presented as a phenogram.

The matrix was subjected to a principal coordinates analysis (Gower 1966, 1967, 1969) (using programs GOWORD or GOWER - refer Williams *et al.* 1971) to produce an ordination of the individuals. The results of this ordination were graphically presented (using program ORD~~X~~ - refer Whiffin 1978).

The above methods used all available characters (with F values greater than 1, at the 0.01 level) to determine the phenetic relations among the populations.

Numerical analysis of Prostanthera aspalathoides

The canonical variate scattergrams (Figs 7, 9, & 10) and the nearest-neighbour phenogram (Fig. 8) suggest that P. aspalathoides is very homogeneous, with the Kangaroo Island populations (population 4 - refer Figs 8 & 10) slightly distinct from the other specimens. The infraspecific structure of P. aspalathoides was examined in more detail. 190 specimens from 22 populations were analysed (Fig. 20). The number of specimens in each population and the localities of each population are listed in Table 9. Using principal component analysis, the characters exhibiting high component scores (on the first three components) included INTER, LL, LLW, BL, BLW, LKL, KL, STHL, STBB, STMX (refer Figs 11 & 12). Therefore these characters contribute most to the total variance of the specimens. STHL and STMX were highly intercorrelated on all components and so STMX was deleted from subsequent analyses. KHDI was also deleted because it was invariant within this species. Canonical variate analysis of the 22 populations produced some clustering on the first two function (Fig. 13). The Kangaroo Island specimens (I, J) form a weakly distinct cluster. Similarly, the population from Bordertown, Kiata, and the Little Desert (A, 9, 0, respectively) also form a more or less distinct cluster. Only 50.7% of the specimens were correctly classified (according to the canonical variate classification results, refer Nie et al. 1975). This low value is to be expected since it would not be realistic to expect each population to be distinct. Although classification results are frequently of minimal value, especially in this type of situation, the result of the reclassification of the populations may (indirectly) indicate relation-

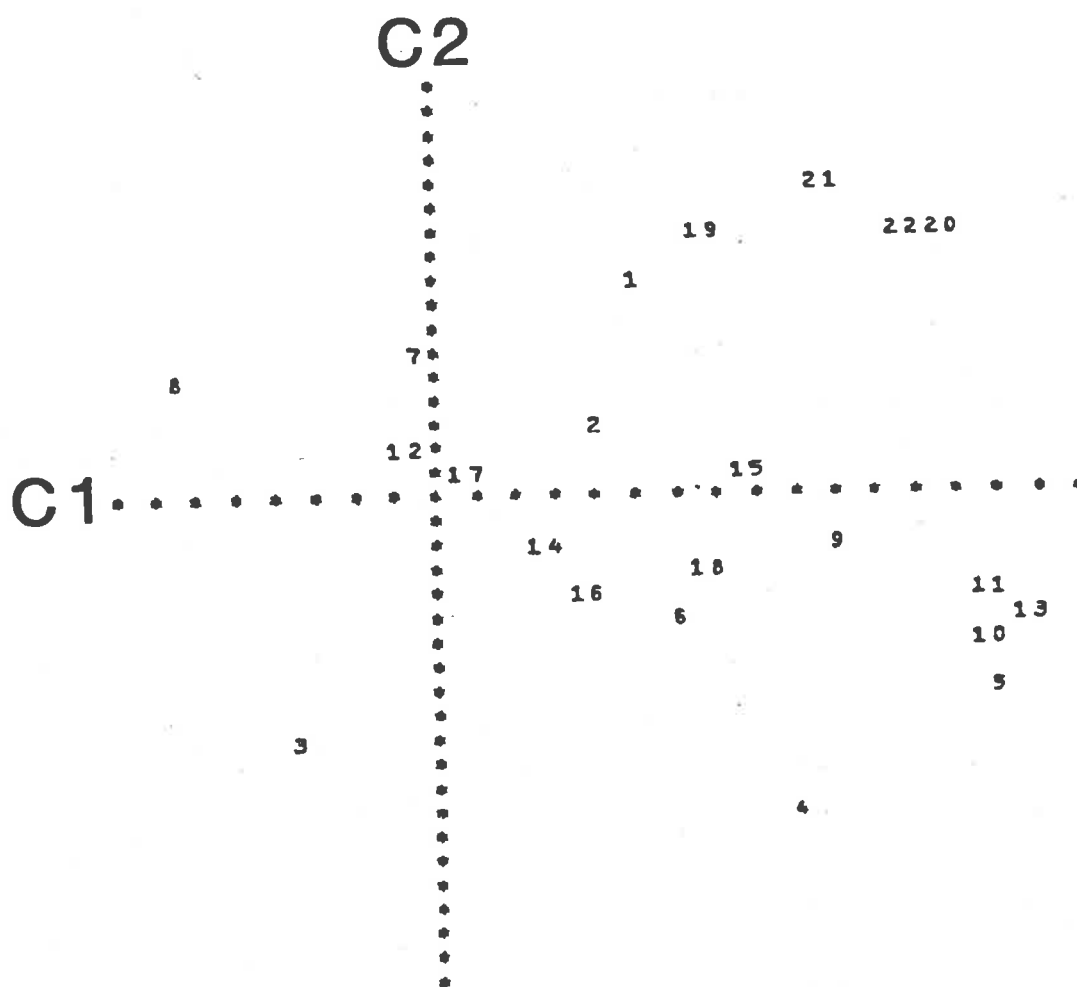


Fig. 11. Principal components plot (component 1 versus component 2) of the character set of *P. aspalathoides*. For details of characters refer Table 1. 1 = INTER; 2 = STHD; 3 = STGD; 4 = LL; 5 = LLW; 6 = LLWL; 7 = LHD; 8 = LGD; 9 = PL; 10 = BL; 11 = BLW; 12 = LKLP; 13 = KL; 14 = KLLT; 15 = KHDO; 16 = KGDO; 17 = KHDI; 18 = AAL; 19 = STHW; 20 = STHL; 21 = STBB; 22 = STMX.

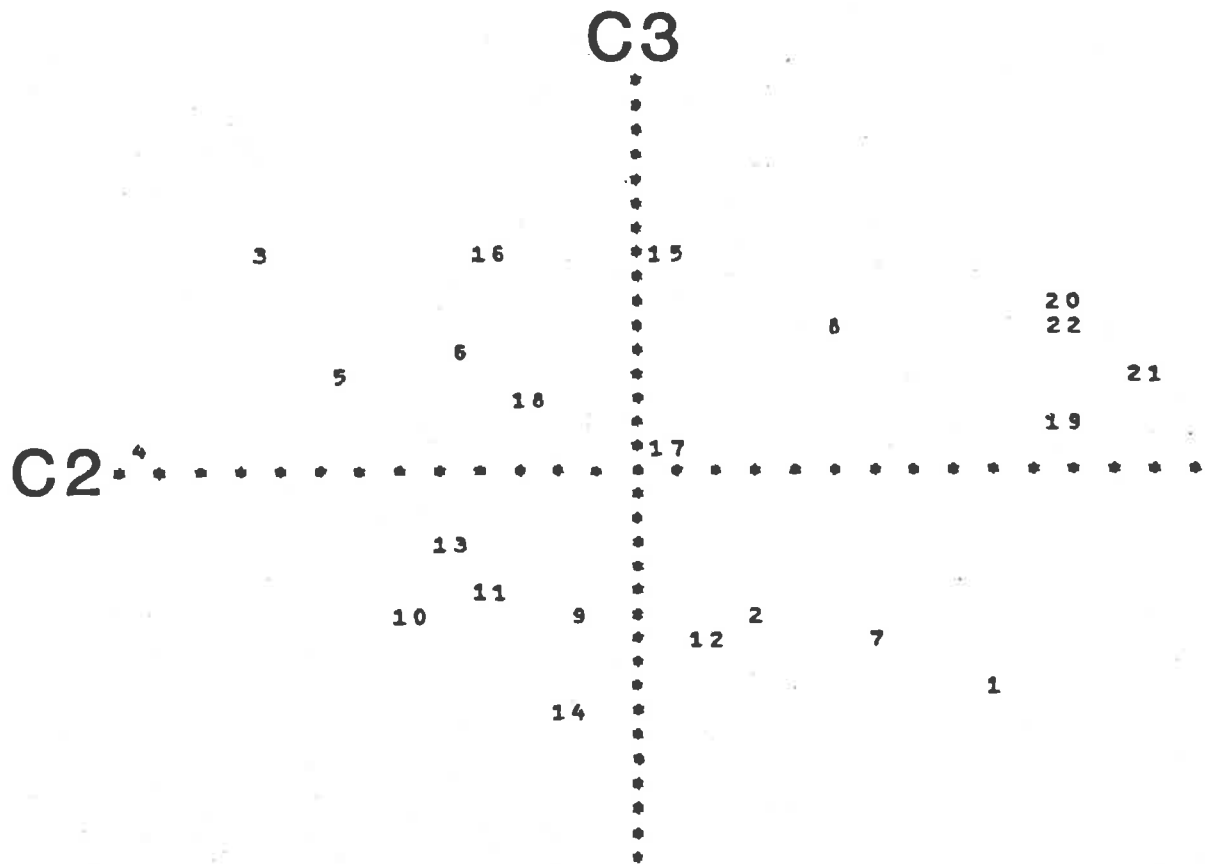


Fig. 12. Principal components plot (component 2 versus component 3) of the character set of *P. aspalathoides*. For details of characters refer Fig. 11 and Table 1.

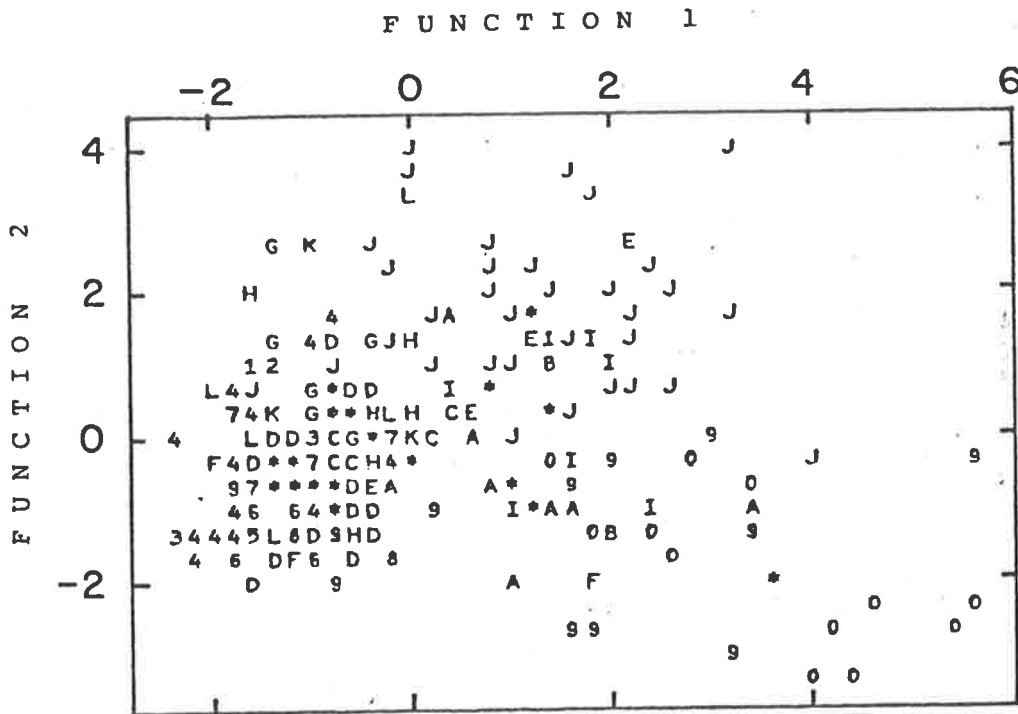


Fig. 13. Canonical variate scattergram (function 1 versus function 2) of *P. aspalathoides*. For details of taxa refer Table 8. 1 = 1; 2 = 2; 3 = 3; 4 = 4; 5 = 5; 6 = 6; 7 = 7; 8 = 8; 9 = 9; 0 = 10; A = 11; B = 12; C = 13; D = 14; E = 15; F = 16; G = 17; H = 18; I = 19; J = 20; K = 21; L = 22; * = group centroid.

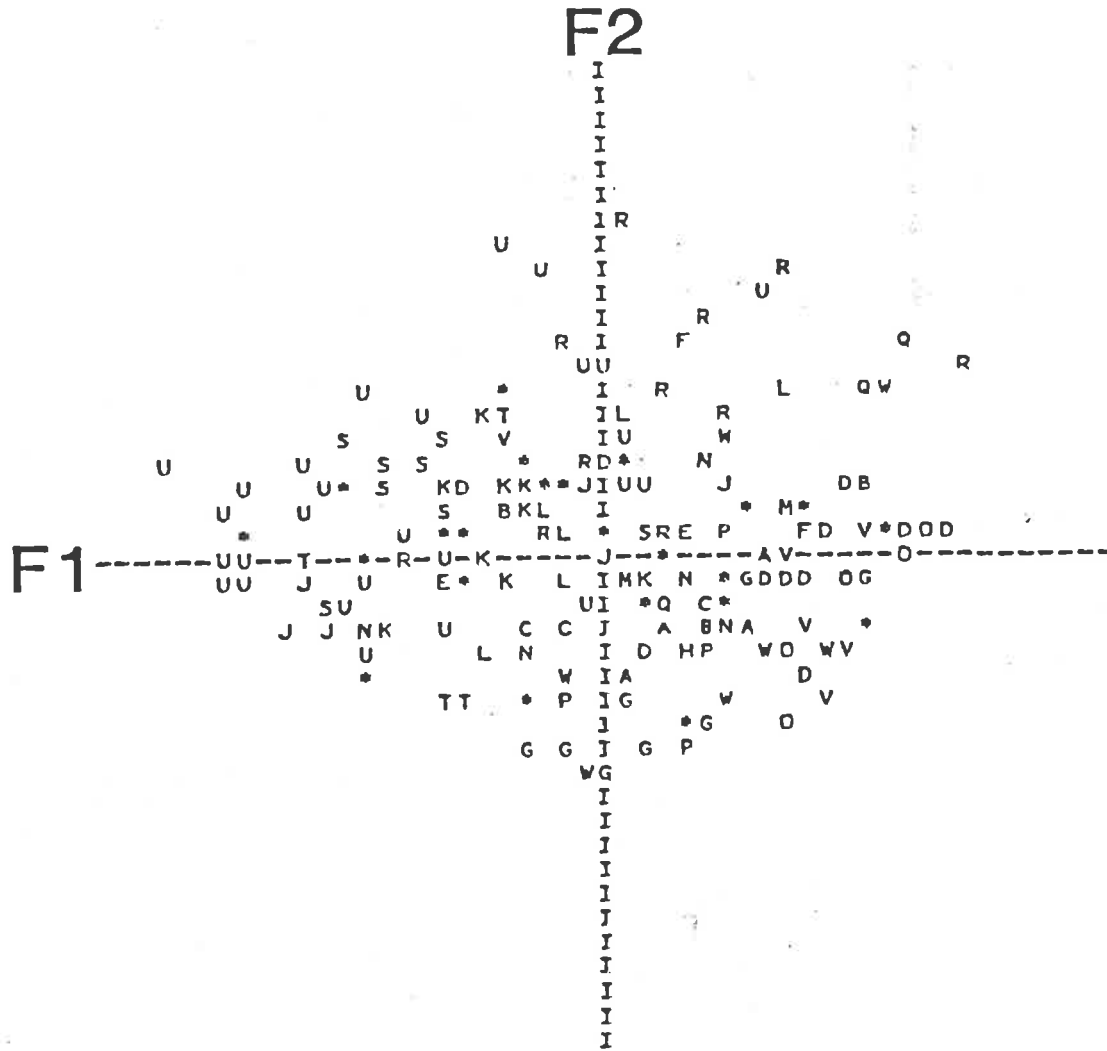
ships. For example, in most cases the reclassification was to a nearby population. However, with respect to the Cobar (1) population, 75% of the specimens were correctly classified, with the other 25% of the specimens being reclassified with the Cowell (K) population. 25% of the Condobolin (2) population was also reclassified with the Cowell (K) population.

The first four axes of the principal coordinates analysis accounted for only 31 % of the total variation. Therefore, these ordinations provided a simplification of the data which is of limited value. The ordination on these axes produces relatively indistinct clusters. The Kangaroo Island populations are weakly distinct from the mainland populations on most axes (Fig. 14 - T, U). Similarly, the Cobar (A), Condobolin (B), West Wyalong (C) and Rankin Springs (D) populations are weakly distinct. However overall, principal coordinates analysis did not provide a useful simplification of the data. Similar results were obtained using the Q-technique of principal component analysis. Furthermore, single-linkage, nearest-neighbour and furthest-neighbour phenograms, generated from the matrix of the Manhattan metric distances, provided little additional information and their complexity reduced their ability to provide a visual simplification of the data.

Therefore, since the morphological variation within P. aspalathoides is more or less continuous, a formal infraspecific classification is not proposed. This morphological variation is discussed in more detail in the 'Geographic Variation' chapter.

Numerical analysis of the Prostanthera calycina - P. microphylla - P. serpyllifolia complex

Prostanthera serpyllifolia and P. calycina are confined to South



- | | |
|--|---------------------|
| A = COBAR | B = CONDOBOLIN |
| C = W. WYALONG | D = RANKIN SPRINGS |
| E = BARELLAN | F = BALRANALD |
| G = BENDIGO | H = WYPERFELD |
| J = KIATA | K = L. DESERT |
| L = BORDERTOWN | M = SCORPION SPRING |
| N = BILLIATT | O = OVERLAND CORNER |
| P = WALKER FLAT | Q = COOMANDOOK |
| R = BRAENDLERS | S = GOOLWA |
| T = AMERICAN RIVER | U = KINGSCOTE |
| V = COWELL | W = WHYALLA |
| * = TWO OR MORE INDIVIDUALS FROM DIFFERENT GROUPS
IF FROM SAME GROUP, THEN GROUP SYMBOL PRINTED | |

Fig. 14. Principal coordinate plot (function 1 versus function 2) of the populations of *P. aspalathoides*.

Australia, whereas P. microphylla occurs in New South Wales, Victoria, South Australia and southern Western Australia. The Victorian populations of the latter species are very homogeneous, all having the calyx hairy on the outer surface, plus an anther appendage. In New South Wales, in the Murray Lands of South Australia, and in Western Australia, the populations are less homogeneous, but are still readily distinguishable from closely related taxa. However, P. microphylla from Eyre Peninsula (South Australia) is extremely variable and is frequently difficult to distinguish from P. serpyllifolia, and to a lesser extent, from P. calycina. The Moonta population (on Yorke Peninsula, South Australia) is typical of much of the collections (of P. microphylla) from New South Wales and Victoria. Therefore, this population was included in this study so that a comparison between the Eyre Peninsula populations and those of the eastern states could be made. The Kangaroo Island populations (5 - 8) were included so as to facilitate an evaluation of the distinctness of these populations from the mainland specimens. 156 specimens from 14 populations were analysed (Fig. 27). The number of specimens in each population and the localities of each are listed in Table 10.

The nearest-neighbour phenogram (based on all characters except KHDI) generated from the matrix of the Manhattan metric distances is presented in figure 15 (for details of collection refer Table 8). The complexity of this phenogram reduces its ability to provide a visual simplification of the data. However, it does provide some information on the infrastructure of this complex.

The various populations represented in this phenogram (Fig. 15) are clearly heterogeneous (cf. the duplicates of Eichler 15172, and the population collections of Conn 684, 1073, 1077, 1078, 1079, 1089, 1090, 1091, 1093, 1096 & 1097). However, the Stenhouse Bay population is relat-

Fig. 15. Nearest-neighbour phenogram (based on all characters except KHDI) generated from the Manhattan distance matrix of 156 specimens of the *Prostanthera calycina* - *P. microphylla* - *P. serpyllifolia* complex. Population numbers are: 1 = Kimba; 2 = Arno Bay; 3 = Lock; 4 = Moonta; 5 = Cape Borda; 6 = Kelly Hill Cave; 7 = Mt Taylor; 8 = Cape Cassini; 9 = Port Lincoln; 10 = Mt Greenly; 11 = Stenhouse Bay (Innes National Park); 12 = Hincks Conservation Park; 13 = Venus Bay; 14 = Streaky Bay. The numbers directly above the phenogram refer to the specimens (refer Table 8 for details of collectors and collection numbers).

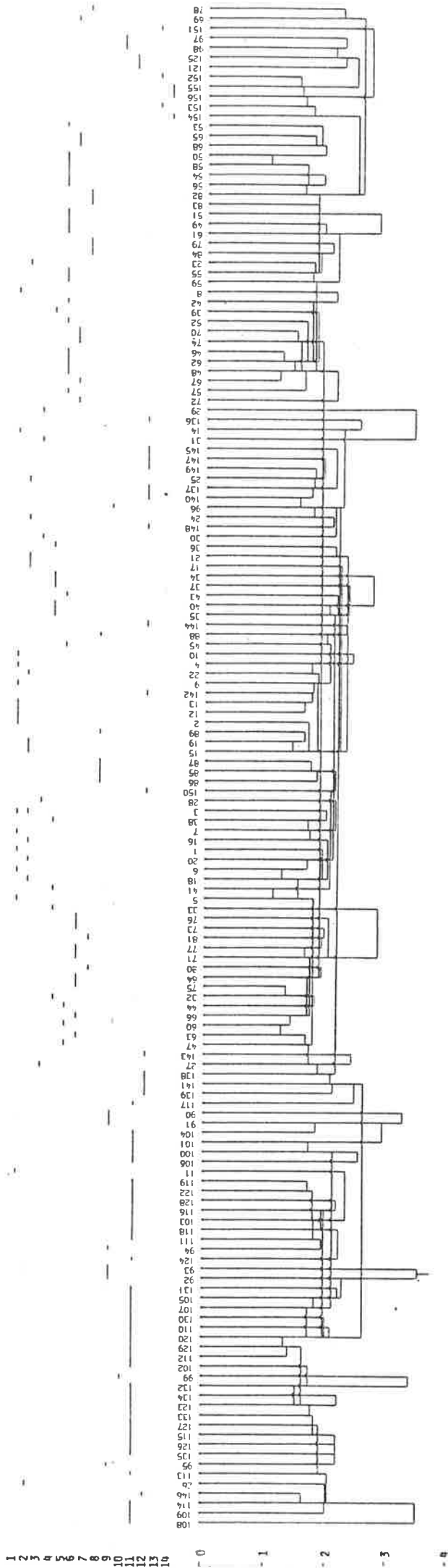


Table 8. Details of the 156 collections used in the numerical analyses of the P. calycina - P. microphylla - P. serpyllifolia complex.

-
- | | | |
|--------------------------------|--------------------------|--------------------------------|
| 1. Hill 652 | 53. Conn 1077e | 105. Copley 4424 |
| 2. Whibley 279 | 54. Conn 1080 | 106. Lothian 2638 |
| 3. Eichler 19193 | 55. Conn 1078a | 107. Blaylock 70 |
| 4. Canning CBG 23620 | 56. Conn 1078b | 108. Copley 4619 |
| 5. Phillips CBG 23621 | 57. Conn 1078c | 109. Jackson 2641 |
| 6. Orchard 2138 | 58. Conn 1079a | 110. Blaylock 1092 |
| 7. Beauglehole 17575 | 59. Conn 1079b | 111. Carrick 3907 |
| 8. Rohrlach 625 | 60. Conn 1079c | 112. Carrick 3913 |
| 9. Orchard 2138 | 61. Eichler 15172 (UC) | 113. Carrick 3904 |
| 10. Rohrlach 158 | 62. Eichler 15172 (AD) | 114. Carrick 3905 |
| 11. Rosier 59 | 63. Conn 1089a | 115. Carrick 3903 |
| 12. Hilton s.n.,27.viii.1955 | 64. Conn 1089b | 116. Carrick 3902 |
| 13. Caulfield 236 | 65. Conn 1089c | 117. Carrick 3901 |
| 14. Wilson 236 | 66. Conn 1090a | 118. Carrick 3906 |
| 15. Tindale 463 | 67. Conn 1090b | 119. Carrick 3908 |
| 16. Ising s.n.,27.viii.1935 | 68. Conn 1090c | 120. Carrick 3909 |
| 17. Alcock 631 | 69. Conn 1091a | 121. Carrick 3910 |
| 18. Whibley 1992 | 70. Conn 1091b | 122. Carrick 3911A |
| 19. Tindale 463 | 71. Conn 1091c | 123. Carrick 3911B |
| 20. Eichler 19171 | 72. Jackson 376 | 124. Carrick 3912 |
| 21. Whibley 7435 | 73. Eichler 15490 | 125. Copley 4425 |
| 22. Alcock 632 | 74. Eichler 18538 | 126. Hill 1080 |
| 23. Ising s.n.,27.viii.1935 | 75. Conn 1093a | 127. Hill 1078 |
| 24. Barker 3639A | 76. Conn 1093b | 128. Copley 4423 |
| 25. Barker 3639B | 77. Conn 1093c | 129. Blaylock 1124 |
| 26. Barker 3639C | 78. Conn 1096a | 130. Heyligers 80127 |
| 27. Phillips CBG 23546 | 79. Conn 1096b | 131. Smith 779 |
| 28. Phillips CBG 23846 | 80. Conn 1096c | 132. Kraehenbuehl 864 |
| 29. Puckridge s.n., anno. 1962 | 81. Conn 1097a | 133. Alcock 4539 |
| 30. Tindale 590 | 82. Conn 1097b | 134. Spooner 6171 |
| 31. Phillips CBG 23783 | 83. Conn 1097c | 135. Copley 4897 |
| 32. Gill 152 | 84. Jackson 852 | 136. Cleland s.n. 12.viii.1964 |
| 33. Beythieu 92 | 85. Conn 1073a | 137. Symon 6158 |
| 34. Beythieu 91 | 86. Conn 1073b | 138. Wheeler 801 |
| 35. Phillips CBG 23839 | 87. Conn 1073c | 139. Alcock 2202 |
| 36. Donner 1871 | 88. Conn 1073d | 140. Cleland s.n. 17.ix.1966 |
| 37. Copley 4091 | 89. Conn 1073e | 141. Wheeler 748 |
| 38. Copley 770 | 90. Browne s.n. (MEL) | 142. Symon 6319 |
| 39. Phillips CBG 31378 | 91. Specht 2706 | 143. Symon 6192 |
| 40. Copley 2285 | 92. Wilson 410 | 144. Symon 6320 |
| 41. Tepper s.n., anno. 1874 | 93. Wilson 411 | 145. Symon 6426 |
| 42. Eichler 15172 (NSW) | 94. Anon. (AD966032930) | 146. Alcock 2351 |
| 43. Eichler 15172 (MEL) | 95. Whibley 1961 | 147. Alcock 1568 |
| 44. Cleland s.n.,2.ii.1948 | 96. Ising s.n.,17.x.1936 | 148. Cleland s.n. 10.vi.1965 |
| 45. Kirkpatrick s.n.,-xii.1968 | 97. Conn 684A | 149. Specht 2067 |
| 46. Phillips s.n. 28.ix.1965 | 98. Conn 684B | 150. Wheeler 888 |
| 47. Eichler 15172(E) | 99. Conn 684C | 151. Warburton s.n. (MEL) |
| 48. Wheeler 1308 | 100. Hill 1079 | 152. Willis s.n. 26.viii.1947 |
| 49. Conn 1077a | 101. Copley 4519 | 153. Dennis 170 |
| 50. Conn 1077b | 102. Copley 4520 | 154. Weber 6210 |
| 51. Conn 1077c | 103. Weber 4254 | 155. Wrigley CBG 36640 |
| 52. Conn 1077d | 104. Weber 4342 | 156. Copley 4858 |
-

ively distinct from the other populations even though there is a close relationship with several of the Pt Lincoln specimens. The distinctness of this population is also suggested in figures 8 & 9. The Stenhouse Bay population is composed of individuals which are glabrous or very sparsely hairy with a very high glandular density on most organs. They also have more or less shiny leaves which are often thickened. However, this form is regarded as environmentally induced (p. 107). The distinctness of the genotype is unknown, however when additional collections (not used in the numerical analyses) from further inland are considered, these collections tend to be intermediate between the more typical P. serpyllifolia ssp. serpyllifolia and this local form. Therefore, the Stenhouse Bay form is not given formal taxonomic status.

The only other populations which are relatively distinct from the other specimens are the Venus Bay and Streaky Bay populations (Fig. 15, specimens 151 - 156). The specimens from these two populations belong to P. calycina. They tend to be very hairy on the branches and have relatively large calyces. The hairs are simple, stiff, straight and appressed such that the hair apex is directed towards the distal part of the relevant organ (Fig. 60C). When additional specimens (not included in the numerical analyses) are considered, these specimens remain distinct from P. serpyllifolia. P. calycina grows under a different set of environmental factors to that of P. serpyllifolia (pp. 106-111). Hence it is not unexpected that there is also a different phenotypic response to these factors. However, this taxon appears to be genetically distinct since there are a few collections of P. serpyllifolia occurring sympatrically with P. calycina at Venus Bay. Furthermore, cultivated material of this species at the Burrendong Arboretum (N.S.W.) (Conn 793) has retained its phenotypic distinctness from P. serpyllifolia. Therefore, P. calycina is maintained as a distinct

species.

Although certain individual specimens are very distinctive (Fig. 15) the overall homogeneity of the morphological variation of the specimens (also refer Figs 8 - 10) suggest that P. microphylla can not be maintained as a distinct species from P. serpyllifolia. However, this taxon can usefully be recognized as a subspecies of P. serpyllifolia, even though some specimens appear intermediate between the two subspecies. The key differences between these subspecies are summarized in the key to the subspecies of P. serpyllifolia (p. 169).

Numerical analysis of the Prostanthera laricoides complex

Canonical variate analysis of the 8 populations of the P. laricoides complex (Fig. 34) produced distinct clustering on the first two functions (Fig. 16). Populations 1, possibly 3, 4, 7 and 8 are distinct from each other, whereas populations 2, 5 and 6 appear to represent a single group. On the first and third functions, populations 2, 5 and 6 were tightly clustered, whereas population 3 was distinct from the former group and less distinct from population 4. The nearest-neighbour phenogram of the canonical variate distances between group centroids (based on the square root of Mahalanobis' D^2) (Fig. 8) also emphasizes the distinctness of the above groups. It also suggests a close relationship between the Campion, Southern Cross and Mt Churchman populations (F, H & I [in Fig. 34 = 2, 5 & 6, respectively]). In the remaining discussion of this complex, I have included the taxonomic conclusions with the relevant population(s) when these are discussed, so that cross-referencing from the 'Systematic Treatment' to this section will be easier.

The nearest neighbour phenogram of the individual specimens (based on a matrix of Manhattan metric distances of all characters)

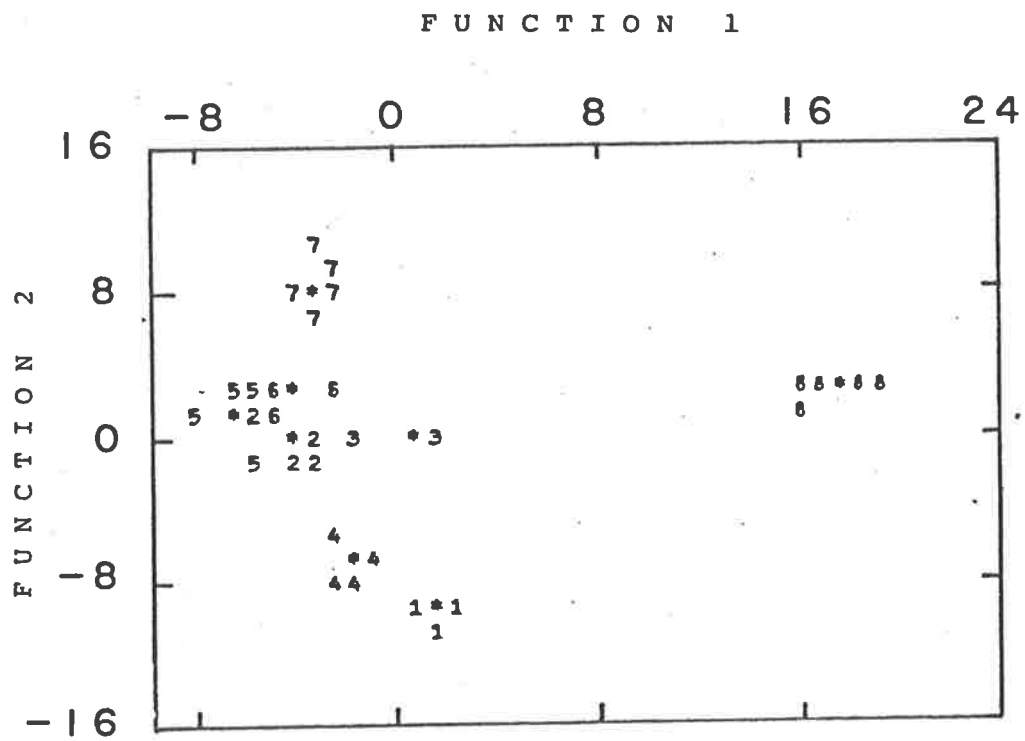


Fig. 16. Canonical variate scattergram (function 1 versus function 2) of the 8 populations of the *P. laricoides* complex. For details of the populations refer Fig. 34 and Table 11.

(Fig. 17) allows for a more detailed evaluation of the infrastructure of these taxa than is possible using group centroids (Fig. 8). Populations 1 (*P. laricoides*), 3 and 4 (*P. incurvata*), and 8 (*P. patens*) are distinct. Populations 2, 5 and 6 (*P. semiteres*) plus population 7 (*P. pedicellata*), represent a closely related, although somewhat heterogeneous group.

The first three axes of the principal coordinate analysis account for 50.87% of the total variation. Therefore, these ordinations provide a useful simplification of the data. The ordination on these axes produces relatively distinct clusters. Population 8 (*P. patens*) is very distinct on all functions (e.g. function one versus two [Fig. 18] and functions two versus three [Fig. 19]). Populations 1, 3 and 4 form a distinct group on functions one versus two (Fig. 19), with *P. laricoides* (1) clearly distinct from *P. incurvata* (3 & 4) on functions one versus two (Fig. 18) and two versus three (Fig. 19). Populations 2, 5 - 7 form a single separate cluster on the first three functions (Figs 18 & 19). Populations 2 and 5 (*P. semiteres* ssp. *semiteres*) are indistinct on all functions. Population 6 (*P. semiteres* ssp. *intricata*) is distinct on the first three functions (Figs 18 & 19), but indistinct on most other functions. Although population 7 (*P. pedicellata*) is closely related to population 6 (*P. semiteres* ssp. *intricata*), the ordination maintains the former as a distinct group (Figs 18 & 19).

I have recognized five species in this complex (viz. *P. incurvata*, *P. laricoides*, *P. patens*, *P. pedicellata*, and *P. semiteres*). The outer surface of the calyx is glabrous in *P. incurvata* and *P. semiteres*, whereas the other species are normally hairy on the outer surface of the calyx. *P. pedicellata* has a long pedicel (7 - 13 mm long) and lacks an anther appendage, whereas *P. patens* and *P. laricoides* have pedicels less than

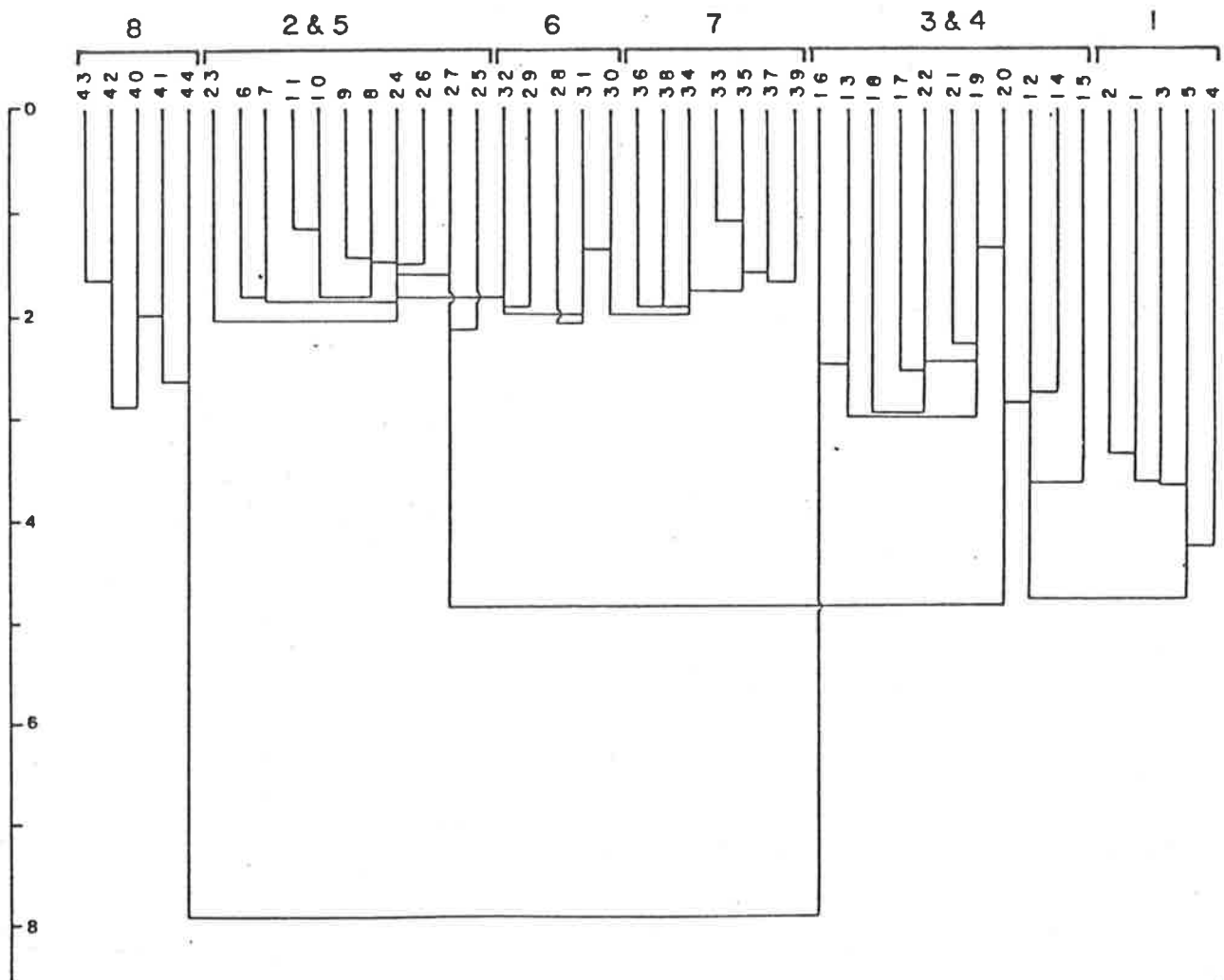
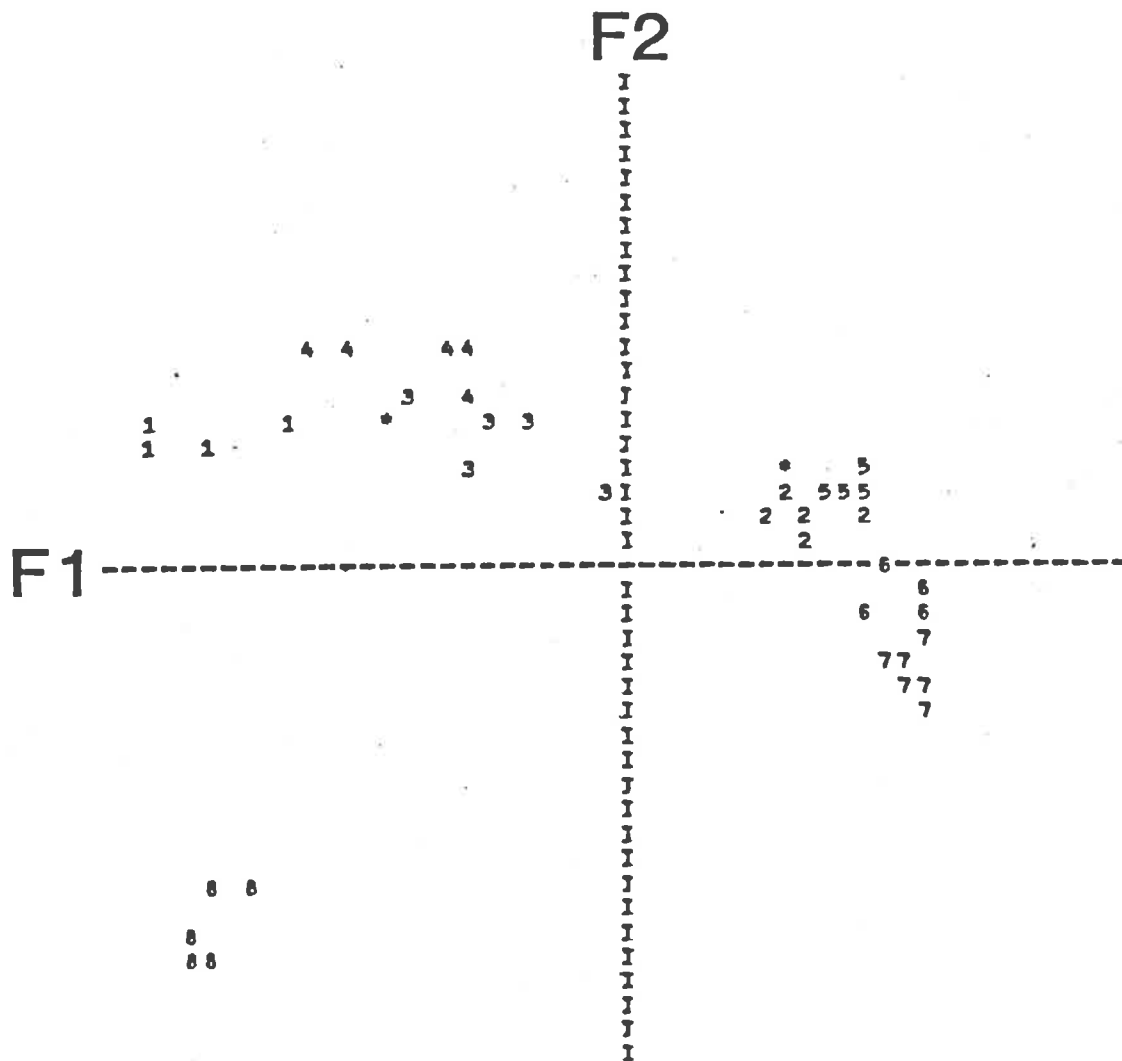


Fig. 17. Nearest neighbour phenogram generated from the Manhattan distance matrix of the 44 specimens of the *P. laricoides* complex (all characters used). Population numbers (as used in Table 11 and Fig. 34) are given above the brackets. The numbers directly above the phenogram refer to the specimens (refer Table 12 for details of collectors and collection numbers).



1 = POPN1	2 = POPN2
3 = POPN3	4 = POPN4
5 = POPN5	6 = POPN6
7 = POPN7	8 = POPN8

* = TWO OR MORE INDIVIDUALS FROM DIFFERENT GROUPS
IF FROM SAME GROUP, THEN GROUP SYMBOL PRINTED

Fig. 18. Principal coordinate plot (function 1 versus function 2) of the populations in the *P. laricoides* complex.

3.5 mm long and they have an anther appendage. These latter two species can be distinguished from each other by P. patens having small leaves (less than 2 mm long), whereas P. laricoides has leaves at least 10 mm long. P. incurvata has hairy branches (rarely glabrous) with pedicels up to 2 mm long and usually incurved leaves which distinguish it from P. semiteres. P. semiteres has glabrous branches (rarely with an occasional hair) with pedicels 3 - 15 mm long and more or less straight leaves.

With the exception of P. patens, the P. laricoides complex is made up of closely related species. P. patens has its closest affinities with P. serpyllifolia, whereas the affinities of the remaining species appear to be with P. aspalathoides.

GEOGRAPHIC VARIATION

Geographic variation is the 'pattern of variation present within a species over its entire range' (Whiffin 1978). Gould and Johnston (1972) summarized the aims of geographic variation studies as: (i) to determine the pattern of variation within a species; (ii) to evaluate the degree of correlation between such patterns and ecological factors; and (iii) to determine if any trends of evolution or speciation are implied by such patterns of variation within the distribution of the species. The detailed analysis of geographic variation provides useful information, especially amongst closely related taxa, on the pattern of variation present, on possible modes of speciation, and on the historical biogeography and lines of migration of the taxa.

Clearly geographic variation is the resultant complex response of many characters to a variety of interdependent environmental and genetical factors. Hence it is a multidimensional process (Fisher 1968). The factors determining and limiting the pattern of distribution of a taxon, within its range, are quite different from those factors which control the extent of its total geographic range. For example, certain ecological factors result in a taxon having a complex mosaic pattern of variation within its total range. Since the very nature of geographic variation is complex, any study of such variation requires the use of various numerical and statistical procedures to simplify and assist in the visualization of the overall pattern of variation present.

Several computer programs, which have been variously modified (written in Fortran 77 [version 5] {Meissner & Organick 1980} for use on the CDC Cyber 173 {CDC. 1981, Fortran version 5 Reference manual, Publ. no. 6048130}, at the University of Adelaide) were used to perform the various analyses

(for details also refer Whiffin 1978). Initially, the original 23 characters were standardized by range ($0 \leq \text{character states} \leq 1$) so as to minimise the effect of large, isolated ('outlying') values. Although not presented here, standardization by standard deviation appeared to be equally useful. The population means for each character were computed and weighted by the $F - 1$ value (Adams 1975). Since the specimens were divided a priori into groups (populations), the characters were weighted according to their ability to distinguish among the groups. Those characters which had the most significant between-group variation carried the most weight in the subsequent analyses. All characters with F values less than 1 (at the 0.01 level) were rejected and so, were not used in subsequent analyses. The data was also subjected to the Student-Newman-Keuls (SNK) multiple range procedure (Adams 1969, 1970b, 1972a; Sokal 1965; Sokal & Rohlf 1969) (using program SNK) to determine which population means were significantly different (at the 0.01 level). The population means of those characters that were significantly different between populations (at the 0.01 level) in both the F test and the SNK test were contoured using surface trend analysis (Adams 1970b, 1970c, 1972a, 1974; Krumbein 1962; Marcus & Vandermeir 1966; Sokal 1965; Turner 1970; Whiffin 1978) (using program CONTRS). Although valuable information concerning geographic variation can be obtain by the consideration of each character separately, it is in general, more useful and more valid to consider all characters (which are significant for both the F test and the SNK test) simultaneously (Whiffin 1978). The multivariate approach is more valid because geographic variation is generally the result of many environmental and genetical factors acting upon the whole genotype. Differential systematics (Adams 1970c, 1972a; Hagmeir 1958, Womble 1951), a multivariate method which maps the composite differential produced by Adams (1970c), was used. Differential systematics gives an

indication of the total trend of several characters simultaneously. It sums the rates of change with distance of several characters and so indicates regions of differentiation. The program DIFSYS (originally written by Adams 1969, 1970c) was used to produce the differential systematics, with the differentials for each character weighted according to their F ratios.

Morphological variation in *Prostanthera aspalathoides*

P. aspalathoides occurs in New South Wales, Victoria and South Australia (Fig. 63). The single collection from St. George, Queensland (R. Jordan s.n.) was not included in this study because one collection could not be expected to represent satisfactorily the morphological structure of the St George population. 190 specimens from twenty-two populations were analysed (Fig. 20). For further details of these populations refer Table 9.

Of the original 23 characters, 16 showed both a significant F-test and a significant SNK test (both at the 0.01 level). Each of these 16 characters was contour-mapped (using program CONTRS). These contour maps show the major regional trends in population means for the characters presented (Whiffin 1978).

Based on the pattern of variation, it is possible to group the contour maps of the characters subjectively into a number of main types. Examples of contour maps of characters in these main types are provided in figures 21-25. A summary of the SNK test (for the relevant character) is provided under each contour map. Any two populations whose means are not underscored by the same line are significantly different for that character, while any two underscored by the same line are not highly significantly different (Sokal & Rinkel 1963; Sokal & Rohlf 1969; Adams 1970c). The populations are ranked in order of magnitude of means for each

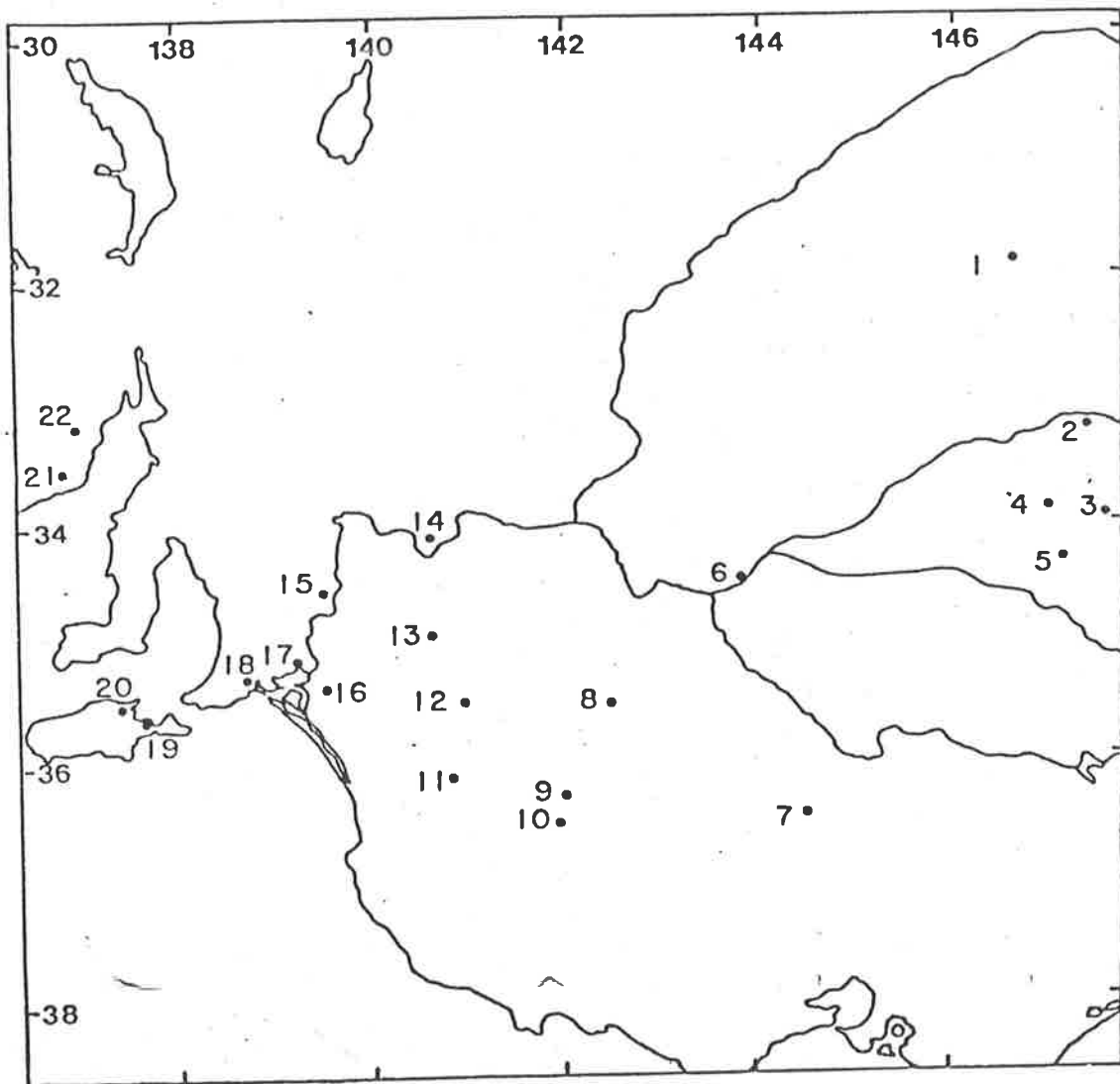


Fig. 20. Locality details of the 22 populations of *P. aspalathoides* used for morphological variation studies. For further details of populations refer Table 9. A separate transparency of this figure is included inside the back cover to be used as an overlay on Figs 21 - 26.

POPULATION	NUMBER OF SPECIMENS/POPULATION
NEW SOUTH WALES	
1. Cobar	4
2. Condobolin	3
3. West Wyalong	7
4. Rankin Springs	15
5. Barellan	3
6. Balranald	7
VICTORIA	
7. Bendigo (Whipstick Mallee)	9
8. Wyperfeld National Park	4
9. Kiata	6
10. Little Desert (SE corner)	10
SOUTH AUSTRALIA	
11. Bordertown	10
12. Scorpion Springs National Park	3
13. Billiatt National Park	6
14. Overland Corner	10
15. Walker Flat	5
16. Coomandook	5
17. Braendler's Scrub (Monarto South)	12
18. Goolwa	11
19. American River	7
20. Kingscote	35
21. Cowell	8
22. Whyalla	10

Table 9. Details of the 22 populations of *P. aspalathoides* used for morphological variation studies.

character. The population with the highest mean being recorded first (on left).

The most common type of pattern of geographic variation is exemplified by the three characters 1) LL - length of lamina (Fig. 21), 2) LPLL - length of petiole to length of lamina ratio (Fig. 22), 3) LP - length of pedicel (Fig. 23). In figure 21, the Kingscote (20) and Little Desert (10) populations have the longest lamina. The populations with slightly shorter lamina (but not significantly different - refer SNK result, Fig. 21), in decreasing order, are Kiata (9), Goolwa (18), American River (19), Balranald (6), Braendler's (17), Bordertown (11), W. Wyalong (3) and Scorpion Springs (12). The more northerly populations of Cobar (1), Condobolin (2), Overland Corner (14), Whyalla (22) and Cowell (21), plus the Bendigo population (7) have short lamina. A similar pattern is found with the length of petiole to length of lamina ratio - LPLL (Fig. 22). Those populations with leaves having the largest ratio (to longest petiole) occur at Balranald (6) and Braendler's (17). As for length of lamina, the Bendigo (7); Overland Corner (14) (with the addition of Walker Flat - 15), Cobar (1) and Condobolin (2) populations have the smallest ratio. The other populations (e.g. Goolwa - 18, Kingscote - 20, Coomandook - 16, Kiata - 9, American River - 19, Bordertown - 11, Scorpion Springs - 12) have intermediate ratios. Both of these characters (LL & LPLL) have high F values (15.81 & 15.68, respectively), while LP (length of pedicel), which shows a similar pattern of variation (Fig. 23), has an F value of 2.47. Therefore, the first two characters account for a more significant amount of the variation.

Another feature, of this most common type, is the frequent significant distinction between the Condobolin (2), West Wyalong (3), Rankin Springs (4), and Barellan (5) populations. Apart from the length of the pedicel -



10 20 09 18 19 06 17 11 03 12 04 05 16 08 02 01 07 13 21 22 14 15

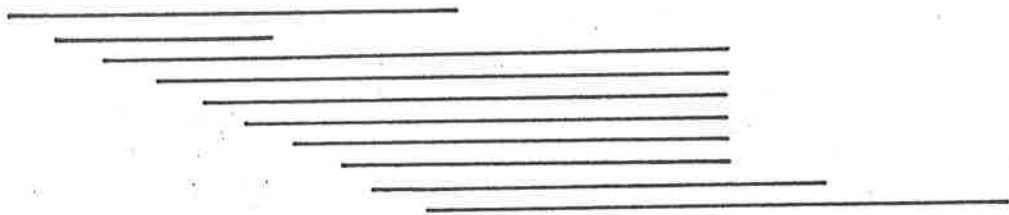
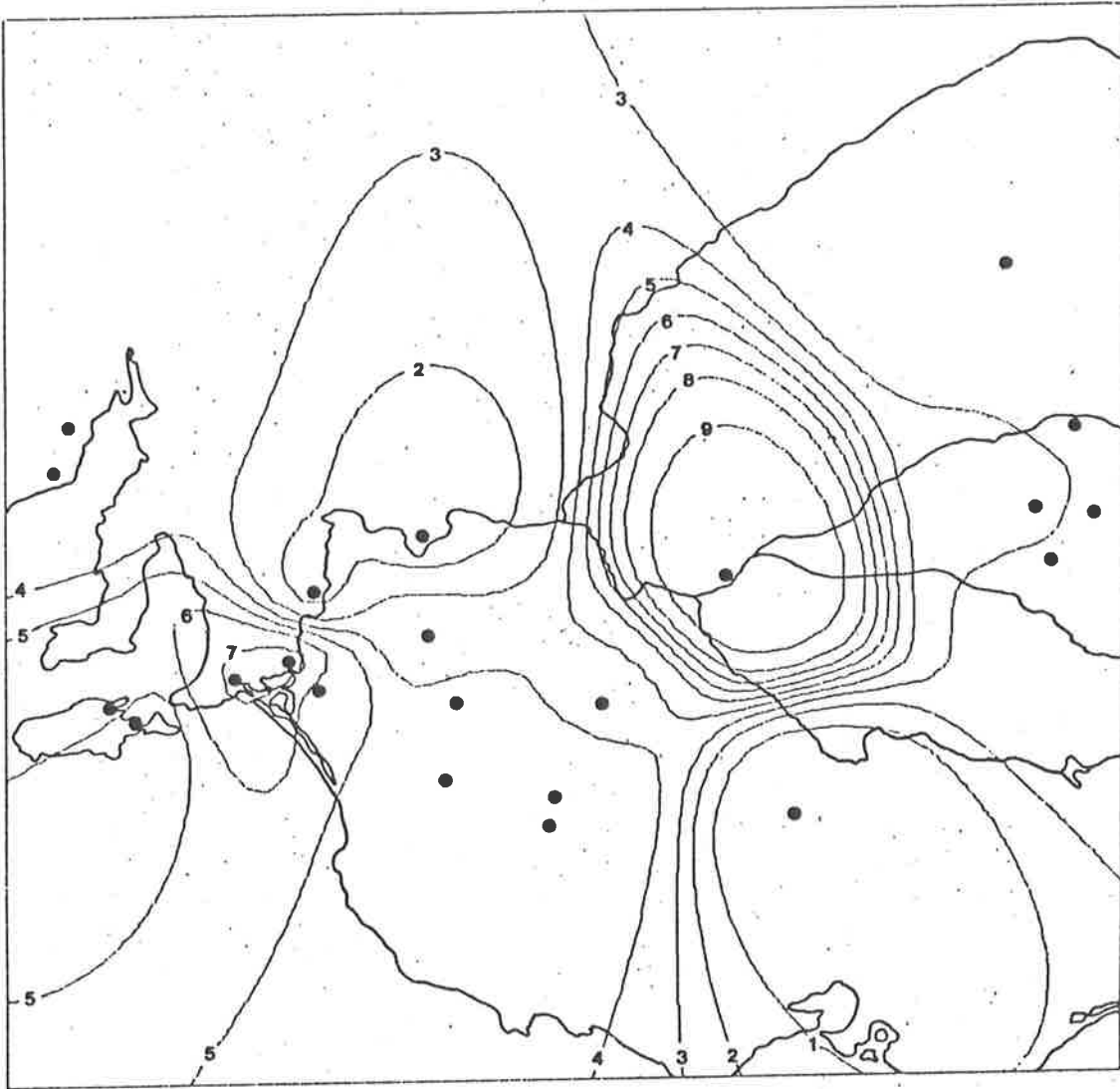
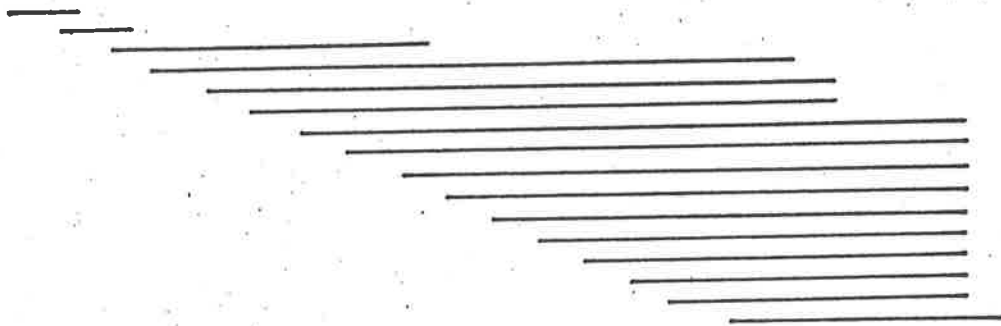


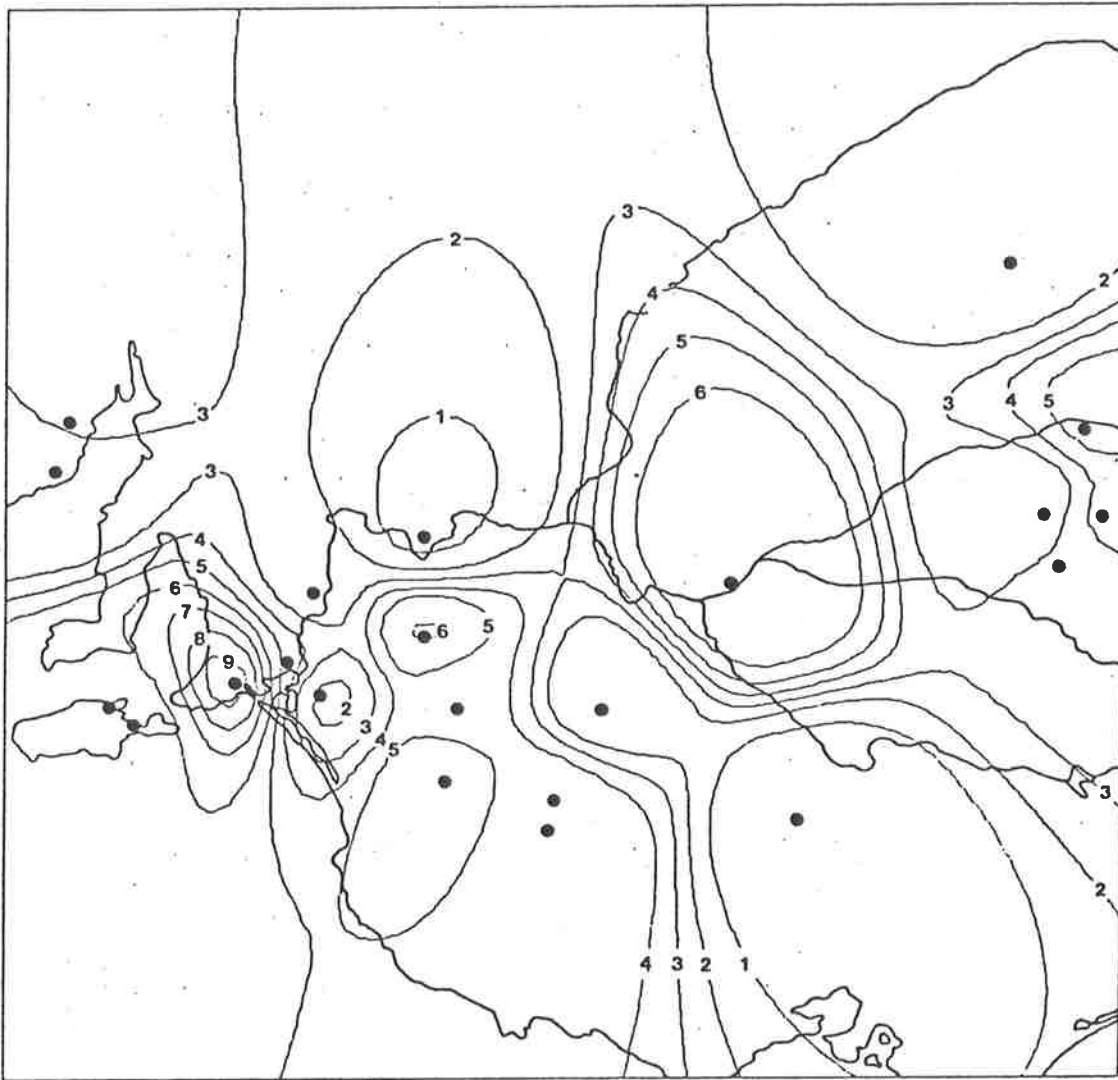
Fig. 21. Contour map (with summary of SNK test) of the lamina length (LL) in populations of *P. aspalathoides*. Contour symbols and values are: 1 = 0.27; 2 = 0.34; 3 = 0.41; 4 = 0.48; 5 = 0.55; 6 = 0.63; 7 = 0.70; 8 = 0.77; 9 = 0.84.

Fig. 22. Contour map (with summary of SNK test) of the petiole length to lamina length ratio (LPLL) in populations of *P. aspalathoides*. Contour symbols and values are: 1 = 4.12; 2 = 4.78; 3 = 5.43; 4 = 6.09; 5 = 6.74; 6 = 7.40; 7 = 8.06; 8 = 8.71; 9 = 9.37.



06 17 18.20 16 09 19 11 12 10 08 22 04 13 21 05 02 01 03 14 15 07





18 06 13 20 11 19 02 10 09 17 03 12 22 05 15 04 21 01 16 08 14 07

Fig. 23. Contour map (with summary of SNK test) of the pedicel length (LP) in populations of *P. aspalathoides*. Contour symbols and values are: 1 = 6.39; 2 = 6.62; 3 = 6.84; 4 = 7.06; 5 = 7.28; 6 = 7.51; 7 = 7.73; 8 = 7.95; 9 = 8.17.

LP (Fig. 23) and the density of hairs on the leaf - LHD (Fig. 24), the density of hairs on the branches (STHD), length of prophylls (LB), length to width ratio of lamina (LLW), and density of glands on the branches (STGD) also distinguish between these population.

The contour map of the density of hairs of the leaf -LHD (Fig. 24) produces a pattern of variation which is more or less opposite to that of the previous examples (i.e. LL, LPLL, LP). The Cowell (21), Condobolin (2), Overland Corner (14), Walker Flat (15) populations have leaves with high densities of hairs, while the Balranald (6) and Goolwa (18) populations have sparsely hairy or glabrous leaves.

The ratio of the length of the calyx to that of the calyx tube - KLLT (Fig. 25) produces a different pattern of variation. However, the northern populations and the Bendigo population have low means for this character, similar to the most common pattern. Furthermore, those populations in the south-west of this species distribution still have intermediate to high values, as found in most other characters. The main difference is that the pattern of variation is much simpler and more populations have lower means than usual.

The composite differential formed from the 16 significant characters is presented in figure 26. High contour levels indicate regions of rapid differentiation (change). The most rapid changes occur between the (i) Bendigo (7) and Balranald (6) populations, (ii) Bendigo and Little Desert (10) - Kiata (9) populations, (iii) Little Desert - Kiata and Wyperfeld (8) populations, (iv) Kangaroo Island (19 & 20) and the mainland (18, 21 & 22) populations. There are also regions of change, however to a lesser extent, among the south-western populations (11-18).

Although the pattern of geographic variation presented (Fig. 26) is



Fig. 24. Contour map (with summary of SNK test) of the density of leaf hairs (LHD) in populations of *P. aspalathoides*. Contour symbols and values are: 1 = 2.21; 2 = 2.31; 3 = 2.41; 4 = 2.51; 5 = 2.61; 6 = 2.72; 7 = 2.82; 8 = 2.92; 9 = 3.02.



10 09 19 11 20 12 04 03 07 13 02 08 17 05 15 14 06 18 01 16 21 22

Fig. 25. Contour map (with summary of SNK test) of the length of the calyx lobes to the length of the calyx tube (KLLT) in populations of *P. aspalathoides*. Contour symbols and values are: 1 = 3.20; 2 = 9.61; 3 = 16.01; 4 = 22.41; 5 = 28.82; 6 = 35.22; 7 = 41.63; 8 = 48.03; 9 = 54.43.



Fig. 26. The composite differential formed from 16 characters in populations of *P. aspalathoides*. Contour symbols and values are:

1 = 0.07; 2 = 0.12; 3 = 0.16; 4 = 0.21; 5 = 0.26; 6 = 0.31.

complex, this only represents a simplification of the actual pattern. Therefore, any explanation of this pattern can only be speculative. However, the main features of figure 26 (in conjunction with the univariate surface trend analysis contour maps) suggest at least one explanation for the pattern observed.

The northern populations (1, 14, 21, & 22) are phenetically homogenous and are distinct, collectively, from the more southerly populations (with the exception of the Bendigo population). These populations (with short, more or less sessile leaves, moderately hairy stems, relatively short pedicels, small calyx lobes, and other character states in common) occur in the Arid Moisture region (Gentilli 1972), which represents a climatic extremity within the distribution of this species.

The southern central region of the distribution (populations 9 - 13, 16 - 18) is an area of complex differentiation, but to a lesser extent than the four major areas of differentiation discussed before (p. 91). Although a high level of homogeneity exists between the populations of this region, subtle differences do exist, but only on a very local scale. This region (SemiArid Moisture region - Gentilli 1972) appears to be climatically optimal for this species. A similar trend occurs in the Rankin Springs - West Wyalong region (populations 2 - 4). This latter region, occurring near the boundary of the SemiArid and SubHumid Moisture regions (Gentilli 1972), is also climatically optimal for this species. The plants in these two regions tend to have larger leaves, frequently with a distinct petiole, longer pedicels, larger calyx lobes, and a number of other characters have similar character states throughout the two regions.

The Bendigo population (7) is relatively distinct (Fig. 26) from the other populations, for example, the leaves are significantly broader

and the branches have significantly fewer glands than the northern populations (1, 14, 21, 22). However, a number of character states are very similar to those found in the northern populations (1, 14, 21, 22), for example, short more or less sessile leaves, short prophylls, short pedicels and small calyx lobes.

It is hypothesized that the Bendigo population occurs at a climatic extremity, as do the northern populations. Although the Bendigo population occurs near the boundary of the SemiArid and the SubHumid Moisture regions (Gentilli 1972), which in New South Wales represents reasonably good conditions for this species, the slightly higher rainfall and the longer, colder periods during winter may represent a climatic extreme. Since both the Bendigo and northern populations have small narrow leaves, a character (in sect. Klanderia) which appears to be easily modified by environmental factors, the climatic regime at Bendigo may be a very real distributional limit. Furthermore, the Bendigo population is relatively isolated by intensive agricultural practices. Therefore, the distinctness of this population will tend to be maintained, since interbreeding with other populations will probably be minimal.

The Kangaroo Island populations (19 & 20) are phenetically distinct from the mainland populations (Fig. 26). These populations have long narrow leaves, moderately large petiole length to lamina length ratios, and moderately long pedicels. Clearly, the Backstairs Passage and Investigator Strait represent significant barriers to interbreeding.

Morphological variation in Prostanthera calycina - P. microphylla - P. serpyllifolia complex.

Although the techniques used to study geographic variation were

developed to investigate the morphological variation within a species, the same techniques are here applied to an investigation of the morphological variation found within the Prostanthera calycina - P. microphylla - P. serpyllifolia complex for this region (Fig. 27). 156 specimens from fourteen populations were analysed (Fig. 27). For further details of the populations refer Table 10.

One common type of pattern of geographic variation is illustrated by the density of hairs on the outer surface of the calyx-KHDO (Fig. 28). The Moonta (4), Cape Borda (5), Kelly Hill Caves (6), and Mt Taylor (7) populations have specimens which have the outer surface of the calyx densely hairy. In this respect, these populations are comparable to the populations of Victoria and New South Wales. While the Cape Cassini (8), Stenhouse Bay (11), Port Lincoln (9), Mt Greenly (10), Venus Bay (13), and Streaky Bay (14) populations have specimens which have glabrous calyces or, at least very sparsely hairy. The remaining populations have a hair density, of the outer surface of the calyx, intermediate between the above extremes. A similar pattern occurs for the density of hairs on the leaves-LHD. In general, this type of pattern (refer, Fig. 28) has high values for the particular character, for Moonta (4) and the south-western Kangaroo Island (5 - 7) populations, with the lowest values occurring at the coastal populations 8 - 11, 13 & 14. Populations 1 - 3, & 12 have values intermediate between the two previous groups.

A slight modification of the previous pattern of geographic variation is illustrated by the position of the hairs on the branches - INTER (Fig. 29). As for the previous pattern, the Moonta (4) and the Kangaroo Island (5 - 7, and now, also 8) populations have hairs on all 'sides' of the branches. However, low values (\approx glabrous branches) are now restricted

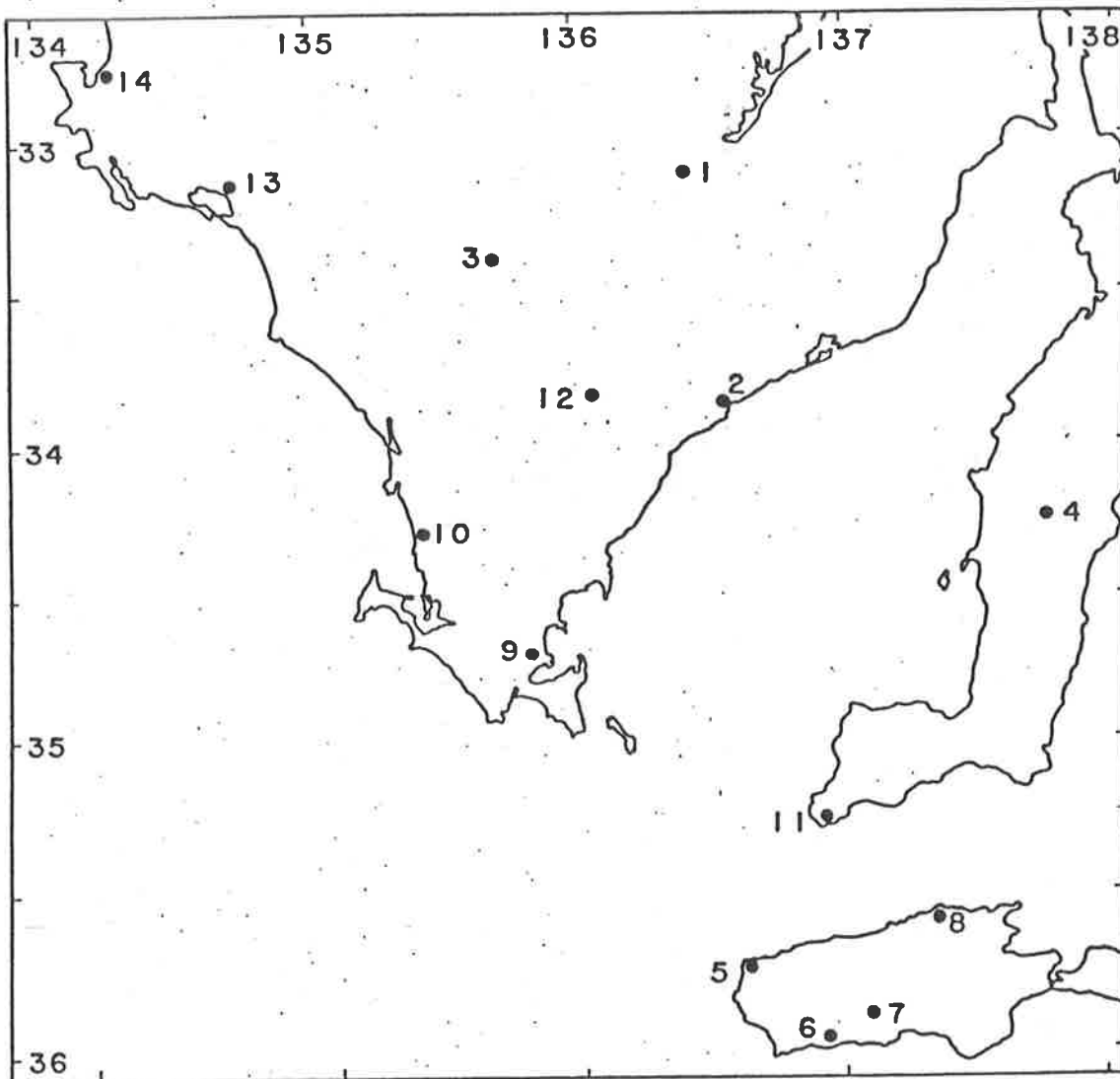


Fig. 27. Locality details of the 14 populations of the *P. calycina* - *P. microphylla* - *P. serpyllifolia* complex used for morphological variation studies. For further details of populations refer Table 10. A separate transparency of this figure is included inside the back cover to be used as an overlay on Figs 28 - 33.

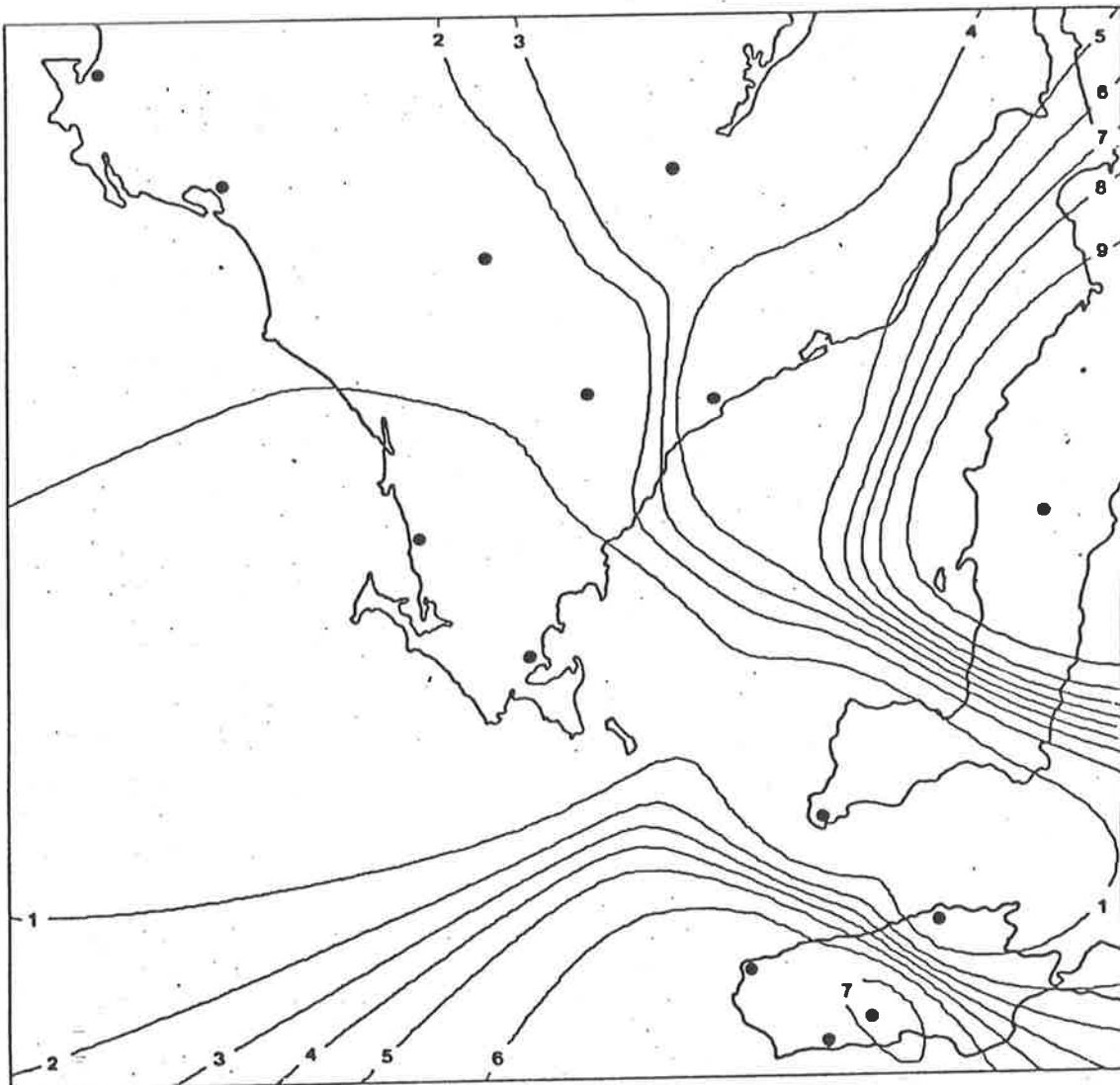
POPULATION

NUMBER OF SPECIMENS/POPULATION

SOUTH AUSTRALIA

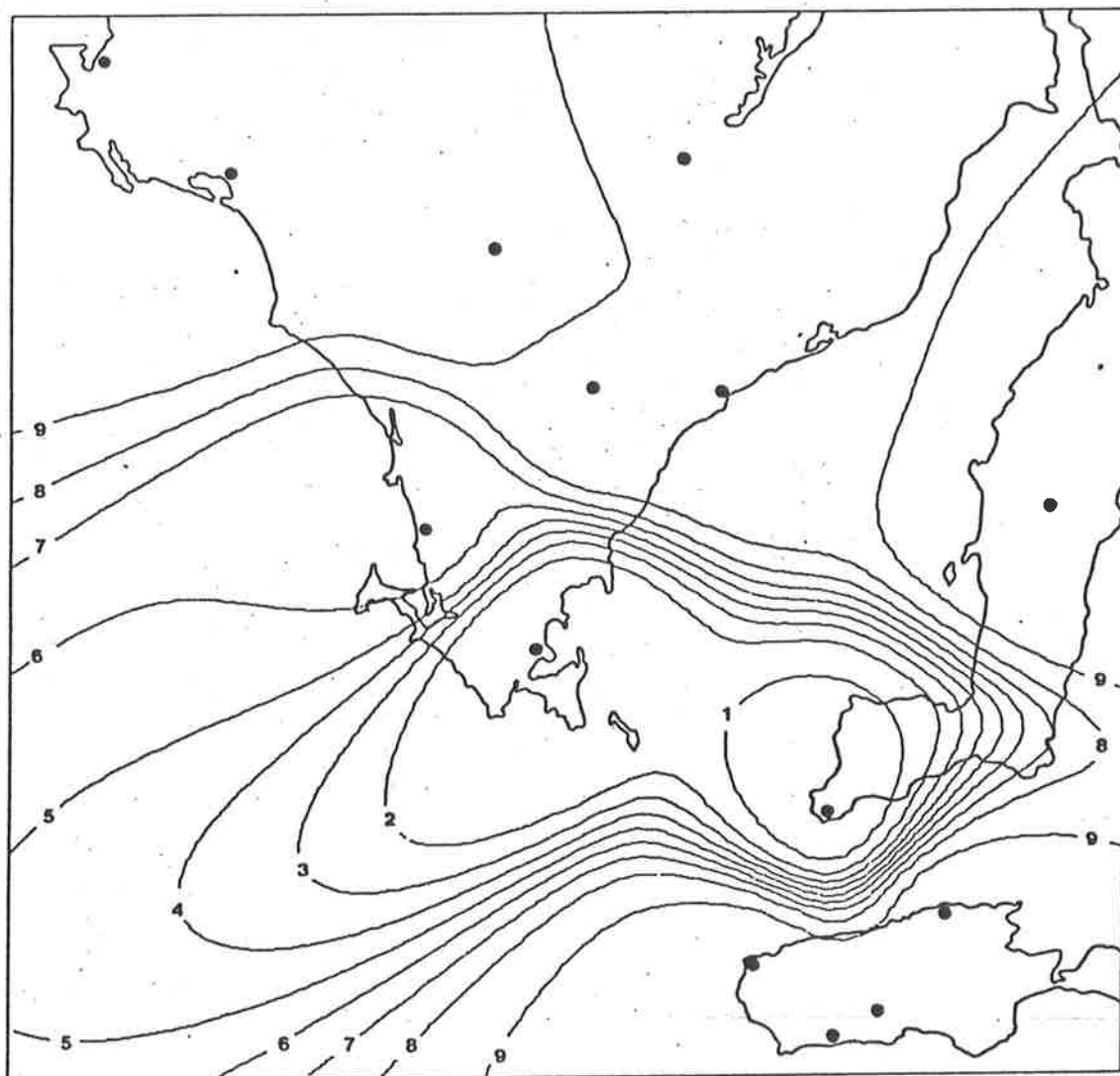
1. Kimba	14
2. Arno Bay	12
3. Lock	5
4. Moonta	10
5. Cape Borda	21
6. Kelly Hill Cave	15
7. Mt Taylor	7
8. Cape Cassini	5
9. Port Lincoln	7
10. Mt Greenly	3
11. Stenhouse Bay	36
12. Hincks Conservation Park	15
13. Venus Bay	3
14. Streaky Bay	3

Table 10. Details of the 14 populations of the *P. calycina* - *P. microphylla* - *P. serpyllifolia* complex used for morphological variation studies.



04 07 06 05 02 01 03 13 14 12 10 09 11 08

Fig. 28. Contour map (with summary of SNK test) of the density of hairs on the outer surface of the calyx (KHDO) for populations of the *P. calycina* - *P. microphylla* - *P. serpyllifolia* complex. Contour symbols and values are: 1 = 2.63; 2 = 7.68; 3 = 12.73; 4 = 17.78; 5 = 22.83; 6 = 27.88; 7 = 32.93; 8 = 37.98; 9 = 43.03.



03 04 05 06 07 08 13 14 12 01 02 10 09 11

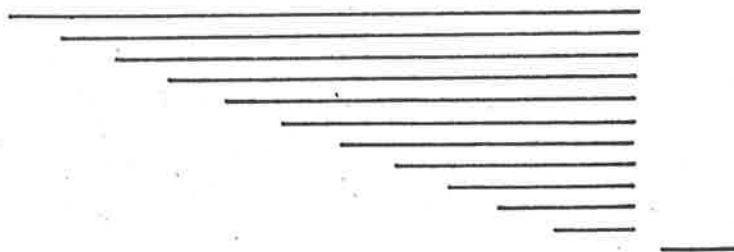


Fig. 29. Contour map (with summary of SNK test) of the position of hairs on the branches (INTER) for populations of the *P. calycina* - *P. microphylla* - *P. serpyllifolia* complex. Contour symbols and values are: 1 = 1.14; 2 = 1.24; 3 = 1.34; 4 = 1.44; 5 = 1.54; 6 = 1.64; 7 = 1.75; 8 = 1.85; 9 = 1.95.

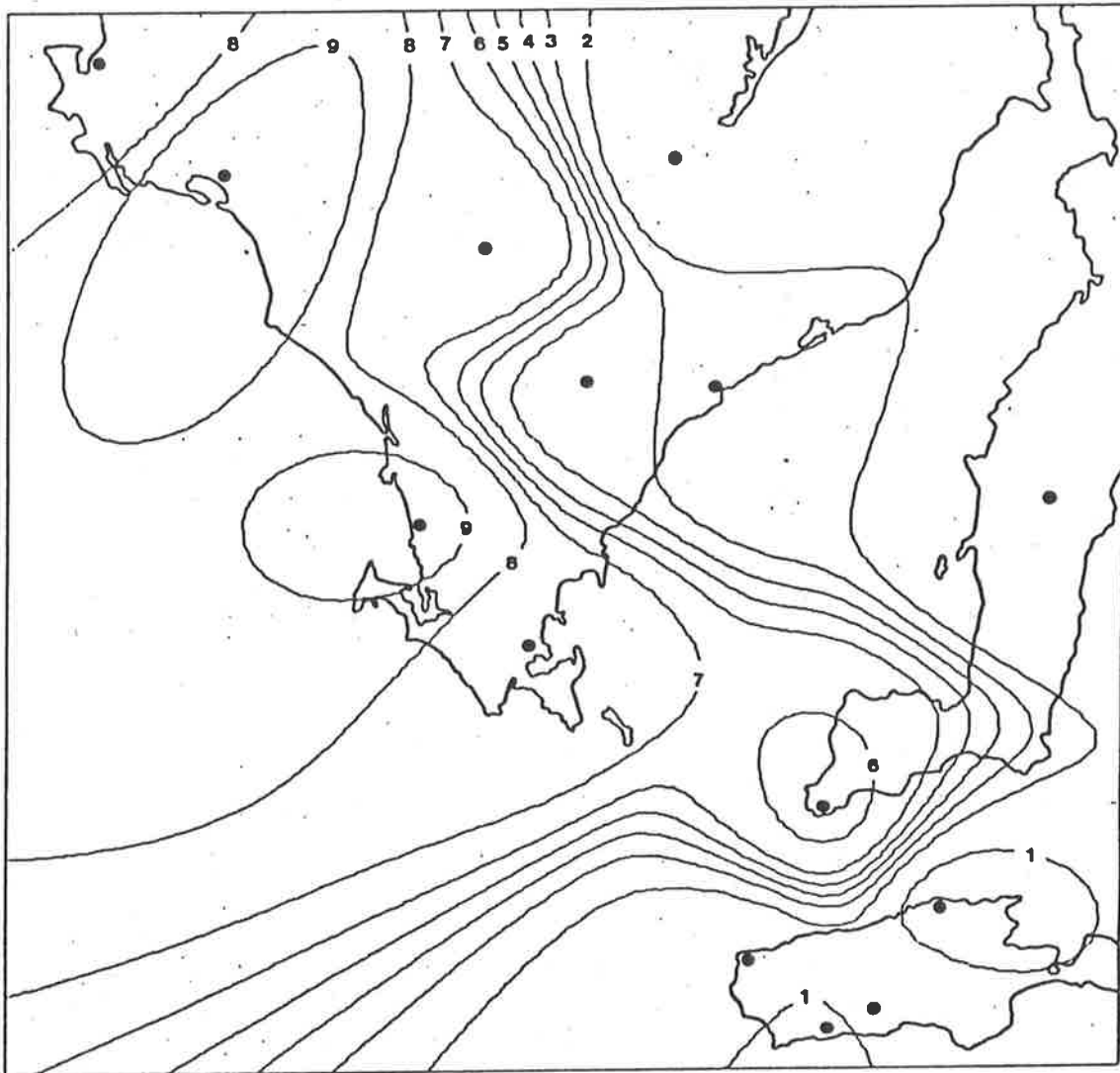
to the Stenhouse Bay (11) and Pt Lincoln (9) populations. Those populations (1 - 3, 12) with intermediate values in the previous pattern, plus the Venus Bay (13) and Streaky Bay (14) populations, all have high values in this pattern. A similar trend, with some further subtle modifications, is found for the length of the anther appendage (AAL).

A third pattern of variation is exemplified by the lamina length -LL (Fig. 30), prophyll length (BL), and calyx length (KL). The mainland (9 - 11, 13 & 14) populations (with the exception of Arno Bay - 2) have significantly high values. For example, these populations have long leaves (Fig. 30), long prophylls and large calyces. The Kangaroo Island populations (5 - 8) and the other mainland populations have significantly low values. Hence, in the example illustrated in figure 30, these populations have short leaves.

The contour map of the pedicel length - PL (Fig. 31) produces a fourth major pattern of geographic variation which emphasizes the distinctness of the Mt Greenly (10) population. Frequently, the Pt Lincoln (9) population is not significantly different from the Mt Greenly population (refer SNK results, Fig. 31). A similar pattern occurs for the lamina length to lamina width (LLW), and for the density of glands on the calyx (KGDO).

Although the above five patterns of variation are the most common, a number of other patterns are found. However, the characters with high F values show patterns of one of these five main types.

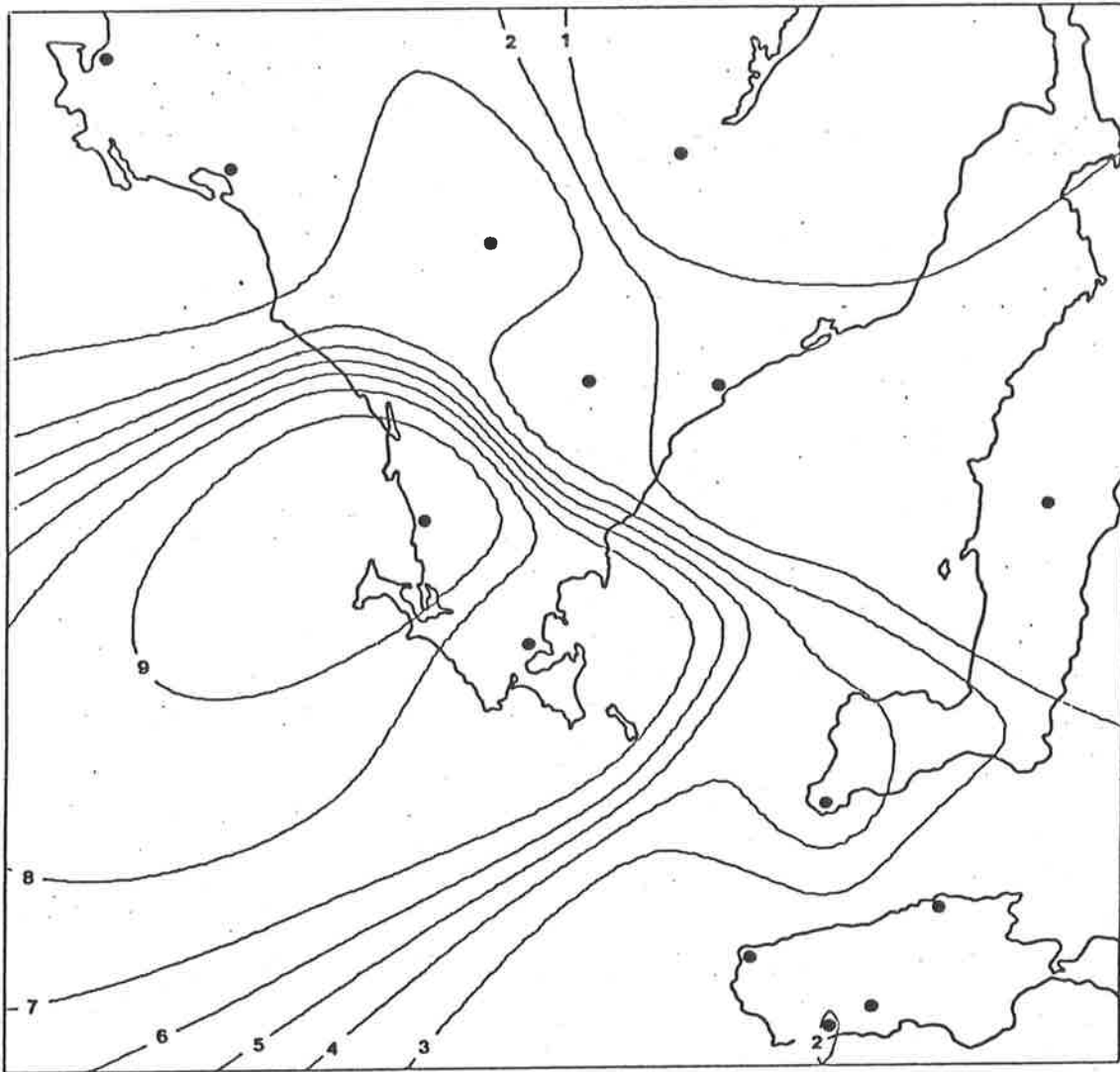
The composite differential formed from the 18 characters which showed both a significant F - test and a significant SNK test (both at the 0.01 level) is presented in figure 32. The most rapid changes occur between the (i) Kangaroo Island (5 - 8) and the mainland populations, (ii)



13 10 03 09 11 14 12 02 07 05 01 04 08 06



Fig. 30. Contour map (with summary of SNK test) of the lamina length (LL) for populations of the *P. calycina* - *P. microphylla* - *P. serpyllifolia* complex. Contour symbols and values are: 1 = 1.93; 2 = 2.39; 3 = 2.85; 4 = 3.31; 5 = 3.77; 6 = 4.23; 7 = 4.69; 8 = 5.14; 9 = 5.60.



10 09 11 03 13 14 05 12 08 07 06 04 02 01

Fig. 31. Contour map (with summary of SNK test) of the pedicel length (LP) for populations of the *P. calycina* - *P. microphylla* - *P. serpyllifolia* complex. Contour symbols and values are: 1 = 1.78; 2 = 2.75; 3 = 3.73; 4 = 4.70; 5 = 5.68; 6 = 6.66; 7 = 7.64; 8 = 8.62; 9 = 9.59.

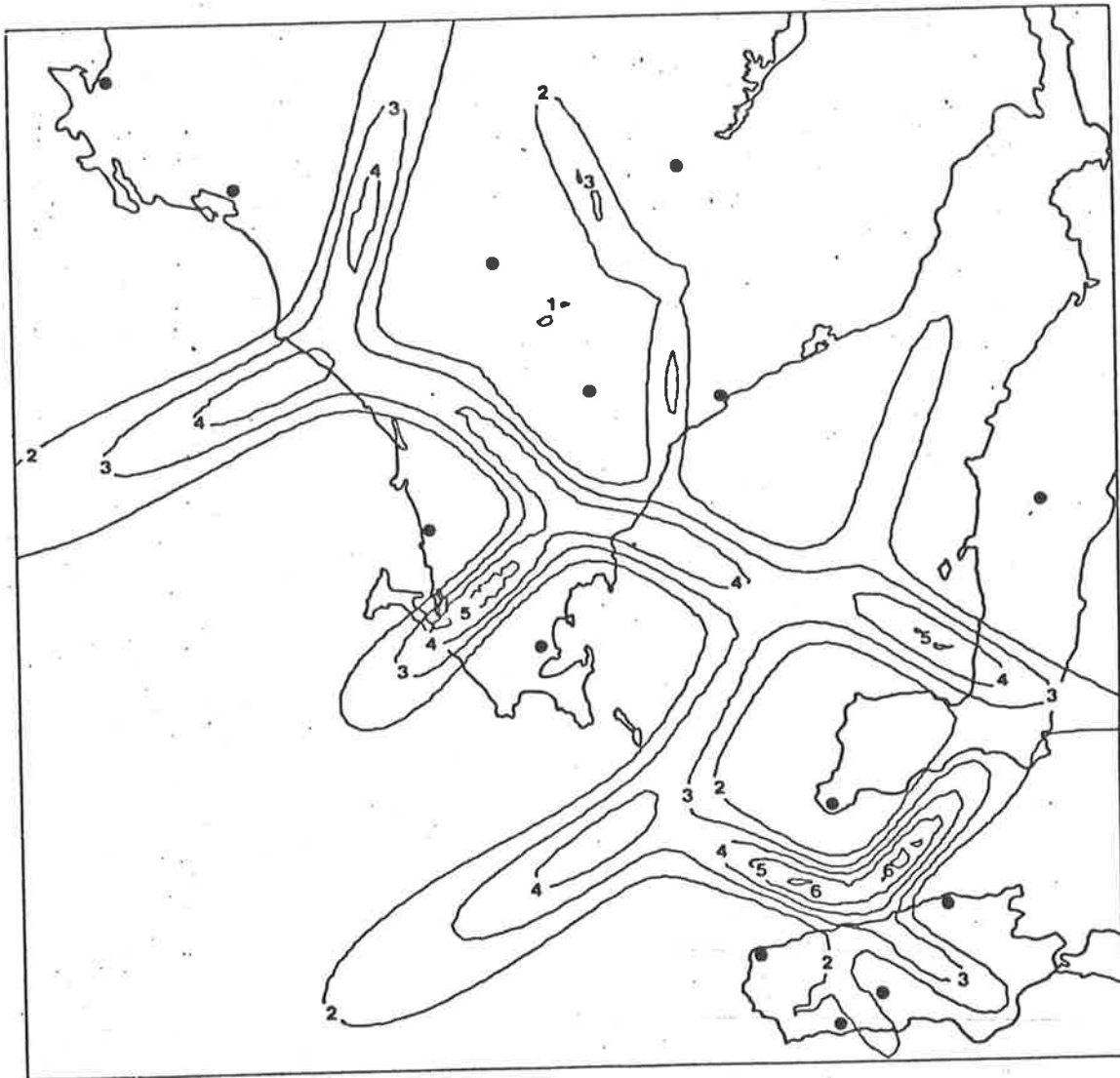


Fig. 32. The composite differential formed from 18 characters in populations of the *P. calycina* - *P. microphylla* - *P. serpyllifolia* complex. Contour symbols and values are: 1 = 0.04; 2 = 0.06; 3 = 0.09; 4 = 0.11; 5 = 0.14; 6 = 0.16.

Stenhouse Bay (11) and Moonta (4) populations, (iii) Stenhouse Bay and Eyre Peninsula (1 - 3, 9 & 10, 12 - 14) populations, while within Eyre Peninsula, the following populations show high levels of distinctness, (iv) Pt Lincoln (9), (v) Mt Greenly (10), and (vi) Venus Bay and Streaky Bay collectively (13 & 14, respectively).

The more northerly populations (1 - 4, 12) (excluding 13 & 14) are more or less strongly differentiated from the other more southerly populations. The Kimba (1), Arno Bay (2) and Moonta (4) populations are collectively very homogeneous. The plants of these three localities have short leaves which are relatively broad, short pedicels and short calyces. In general, the density of hairs on the vegetative parts, pedicels and calyces is significantly greater than the density of glands for these same parts. With respect to the expression of these characters (character states), there is a parallel between these populations and the northern populations of P. aspalathoides (p. 95). Populations from Lock (3) and Hincks (12) are slightly differentiated from the former three populations (1, 2 & 4). The plants from these two localities frequently tend to have character states which are intermediate between the former three populations (1, 2 & 4) and the four coastal populations (9, 10, 13, & 14) (Figs. 28 & 30). Overall, this is an area of phenetic heterogeneity, with some characters having character states similar to populations 1 and 2, whereas other characters having character states similar to some or all of the southern and western coastal populations (9, 10, 13 & 14).

There are strong coastal environmental factors operating on the mainland populations of 9 - 11, 13 & 14. A 'ridge' of strong differentiation separates populations 4 from 11, and 3 and 12 from 9, 10, 13 & 14 (Fig. 32). All of these populations (9, 10, 13 & 14) tend to be more glandular than

the inland populations, except for the Venus Bay and Streaky Bay (13 & 14) populations which are very hairy. These coastal populations also have larger, shiny leaves which are often thickened, longer prophylls, longer pedicels (except populations 13 & 14), and larger calyces than the inland specimens. These features are typical of many coastal species, e.g. Ixodia achillaeoides (Compositae) (Copley 1982), Euphrasia collina ssp, tetragona (Scropulariaceae) (Barker 1982). Other examples and further details are given in Specht (1972; and literature cited therein). It is proposed that the phenotype of these coastal plants is significantly affected by environmental factors. The constitution of the genotype is not known, as my attempts to transplant specimens from these areas were unsuccessful. However, P. calycina has been cultivated (refer p. 74) and it maintained its distinctness.

Three major regions of differentiation occur between the five coastal populations being considered. The two western populations (13 & 14) which represent P. calycina [for numerical analysis of this species refer pp. 69 - 75] are distinct from the other populations (Fig. 32). The specimens from all the other populations belong to P. serpyllifolia. The Mt Greenly (10) population is characterized by specimens with long pedicels. This is further discussed under P. serpyllifolia (p. 173). The distinctness of population 9 (Fig. 32) is almost certainly, largely an environmentally induced effect. Furthermore, when additional collections (not used in the production of the composite differential) are considered, this population is very heterogeneous and tends to intergrade with population 12. The Stenhouse Bay population (11) is made up of individuals which are glabrous or very sparsely hairy. These specimens have a very high glandular density on most organs. The taxonomic importance of the Mt Greenly form and the Stenhouse Bay form is not known. It seems unlikely that examination of normal macromorphological characters will resolve this part of the P. serpyllifolia-P. microphylla complex.

The Investigator Strait and St. Vincents Gulf represent significant barriers to interbreeding between the Kangaroo Island (5 - 8) and mainland populations (Fig. 32) (cf. P. aspalathoides, p. 96). The Kangaroo Island populations differentiate into two main groups. One group, which is represented by the Cape Borda (5), Kelly Hill Caves (6) and Mt Taylor (7) populations, is generally very hairy with many irregularly branched hairs. These three populations occur in sandy to sandy loam soils, associated with limestone. The habitat of these populations is a Eucalyptus dominated mallee community, with a more or less dense understorey of shrubs and herbs. The Cape Cassini (8) population, which represents the second group, is associated with skeletal soils of exposed coastal limestone cliffs. These plants are more or less prostrate and are salt-pruned. Most characters for the plants at Cape Cassini, show slight (although generally insignificant) differences when compared with populations 5 - 7. However, in general, the plants are glabrous on most organs or at least, usually less hairy (with the occasional exception of branches) than the plants of populations 5, 6 and 7. In contrast to these latter populations, the plants from Cape Cassini have only simple hairs, similar to those found throughout most of section Klanderia. The taxonomic significance of the irregularly branched hairs, as found in the plants of populations 5 - 7 (and P. chlorantha) is not known.

P. calycina and P. serpyllifolia (incl. P. microphylla) occur in soils derived from, or at least associated with calcarenites, with the exception of the Mt Greenly population (and some specimens from Pt Lincoln, p. 175, which were not included in the composite differential) which occurs in association with quartzites and granitic gneisses. The phenotype of the Mt Greenly and Kirton Point (Port Lincoln) populations of P. serpyllifolia may have been induced (at least in part) by the relatively unique geological nature of these areas. Whether there is a corresponding genetic distinctness is not known.

In New South Wales, Victoria, most of Western Australia, and the Murray Mallee region of South Australia, P. serpyllifolia is confined to the SemiArid Moisture region (Gentilli 1972), with phytohydroxeric indices between 5 and 10. In the area dealt with by this study of the pattern of geographic variation (Fig. 27), SubHumid (SH), SemiArid (SA) and Arid (A) Moisture regions occur, with phytohydroxeric indices ranging from approximately 3 to greater than 10. In figure 33, the average annual rainfall (adapted from Laut et al. 1977b, 1977c), annual phytohydroxeric indices and Moisture regions (Gentilli 1972), have been overlaid on the contour map (from differential systematics) for P. calycina and P. serpyllifolia (cf. Fig. 32).

In this region of South Australia, the coast line is deeply indented by elongated gulfs and peninsulas. This alternation of land and water surfaces results in a large number of localized climatic modifications. Although these modifications are too slight to be of regional significance, they represent very important climatic influences for the local biota. The SubHumid Moisture region (phytohydroxeric indices ≥ 10) discontinuously occurs on the western parts of Kangaroo Island, the most southerly point of Yorke Peninsula (Innes National Park), and the southern parts of Eyre Peninsula (Fig. 33). Populations 5 - 7, 9 and 11 occur in this region, whereas populations 4, 8 and 10 occur in the SemiArid Moisture region. As well as the Moonta (4) population being morphologically similar to those populations of Victoria and New South Wales, it also occurs in the same climatic zone. Although the Cape Cassini (8) population occurs in the SemiArid Moisture region, the actual level of aridity is probably greater because it occurs on the exposed coastal cliff. The environmental factors operating on population 8 are dramatically different to that

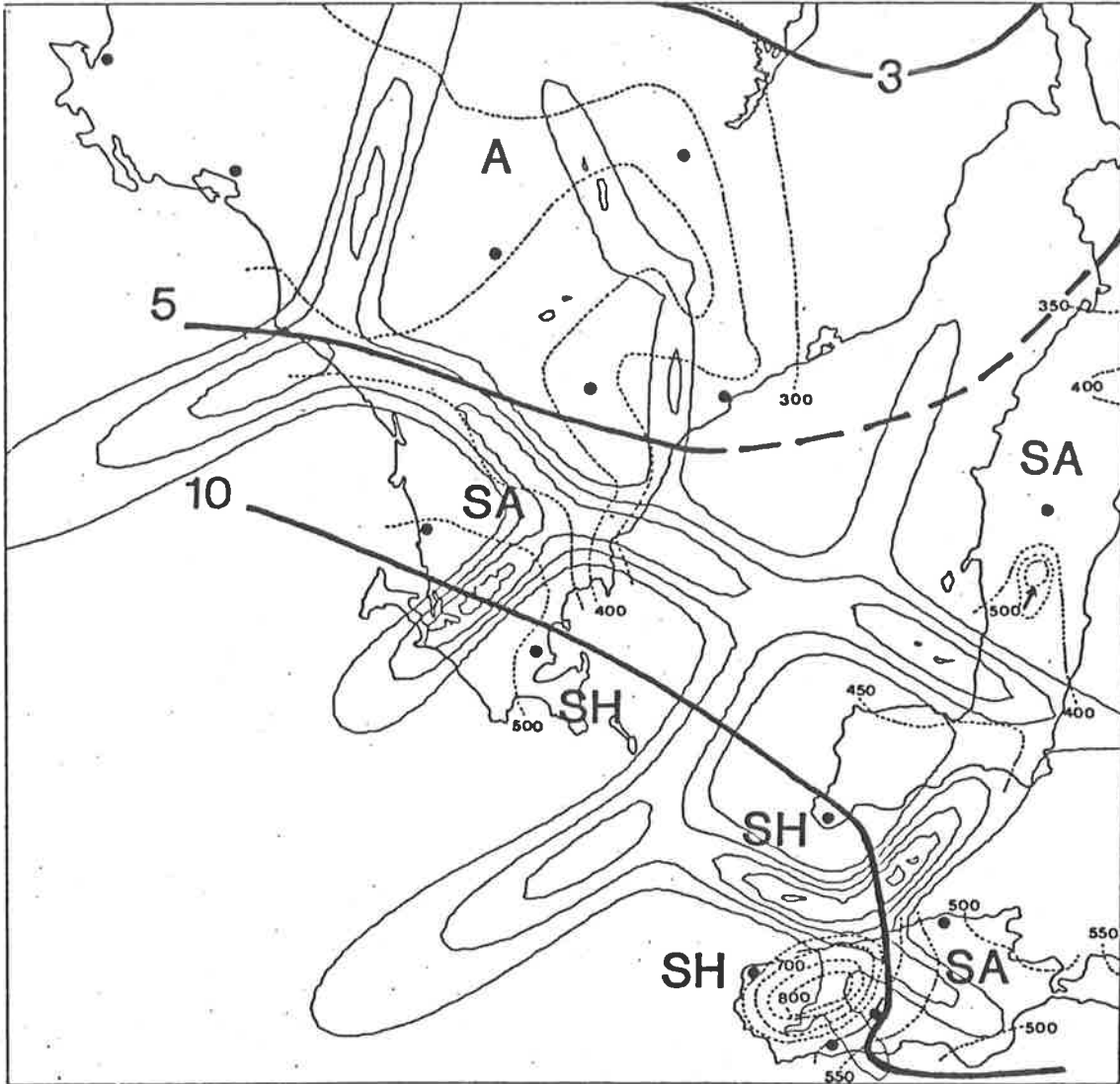


Fig. 33. Annual rainfall distribution (mm) (fine dotted lines), Moisture regions (bold capital letters) and phytohydroxeric indices (bold numbers and lines) overlaid onto the composite differential formed from 18 characters in the populations of the *P. calycina* - *P. microphylla* - *P. serpyllifolia* complex. For contour symbols and values refer Fig. 32. For explanation of symbols used for Moisture regions refer text, p. 109.

operating on the other Kangaroo Island populations (5 - 7). These climatic differences may explain why the Kangaroo Island populations have differentiated into two main groups.

Although Mt Greenly (10) occurs in the SemiArid Moisture region, the local topography associated with its relatively high latitude and proximity to the ocean (hence, increased exposure to the westerly streams of oceanic air), results in this population being under *more* SubHumid conditions than indicated by the generalized climatic map overlaid in figure 33.

The angle of the western coastline of Eyre Peninsula prevents the rain-bearing winds from penetrating deeply inland (Gentilli 1972). Populations 1 - 3 and 12 occur in the Arid Moisture region (phytohydroxic indices between 3 and 5). Although the Arno Bay (2) population is more or less coastal, the major climatic influences are from the west. Therefore, the coastal influences only slightly modify the inland arid conditions. Populations 13 and 14 also occur in this Moisture region because the rain-bearing winds tend to be tangential to the coastline (the isohyets tending to lie parallel to the west coast, Laut *et al.* 1977c, Fig. 1). Since Venus Bay and Streaky Bay occur at lower latitudes, they are not as strongly influenced by the westerly oceanic air currents as are the more southerly land points. Therefore, the Moisture region in association with the high salt content of the air (in this coastal environment), exposes *P. calycina* to a different set of environmental factors when compared with the other coastal populations of Eyre Peninsula.

Morphological variation in the *Prostanthera laricoides* complex

The Western Australian specimens included in this numerical study of section *Klanderia* (excluding *P. serpyllifolia* ssp. *microphylla*), which are

regarded as distinct from the taxa of South Australia and the eastern states (Figs. 6 & 8), were studied in more detail. Previously they were regarded as P. aspalathoides (populations 1 - 7) or P. microphylla (8) (Fig. 34). The details of the eight populations (based solely on herbarium collections), including the number of specimens in each population, are given in Table 11 and figure 34.

Of the original 23 characters, 22 showed both a significant F-test and a significant SNK test (both at the 0.01 level). Characters STBB, STHL, STHW and STMX (refer Table 1) were deleted from the character set because some individuals had glabrous branches. The remaining 19 characters were used in the analysis of the pattern of geographic variation for these taxa.

Considering each character separately, there are four main pattern types. One common type of pattern of geographic variation is illustrated by the length of the anther appendage - AAL (Fig. 35). Populations 1 (P. laricoides) and 8 (P. patens) have specimens which have long appendages on the anthers, whereas the other populations have short appendages or the appendages are absent. Slightly more structure to the pattern of variation is found in the contour map of the position of the hairs on the branches INTER (Fig. 36). P. patens (8) has hairs on all 'sides' of the axes, while P. laricoides (1) and P. incurvata (3 & 4) have hairs on two 'sides'. Populations 5 & 6 (P. semiteres p.p.) and P. pedicellata (7) have glabrous or very sparsely hairy axes. The density of hairs on the branches (STHD), the position of the prophylls (LKLP), and the density of hairs on the outer surface of the calyx (KHDO) all show patterns of variation comparable to this common type. In general, populations 1 (P. laricoides) and 8 (P. patens) have significantly high values for the respective character, whereas the other populations (2 - 7) have significantly low values.

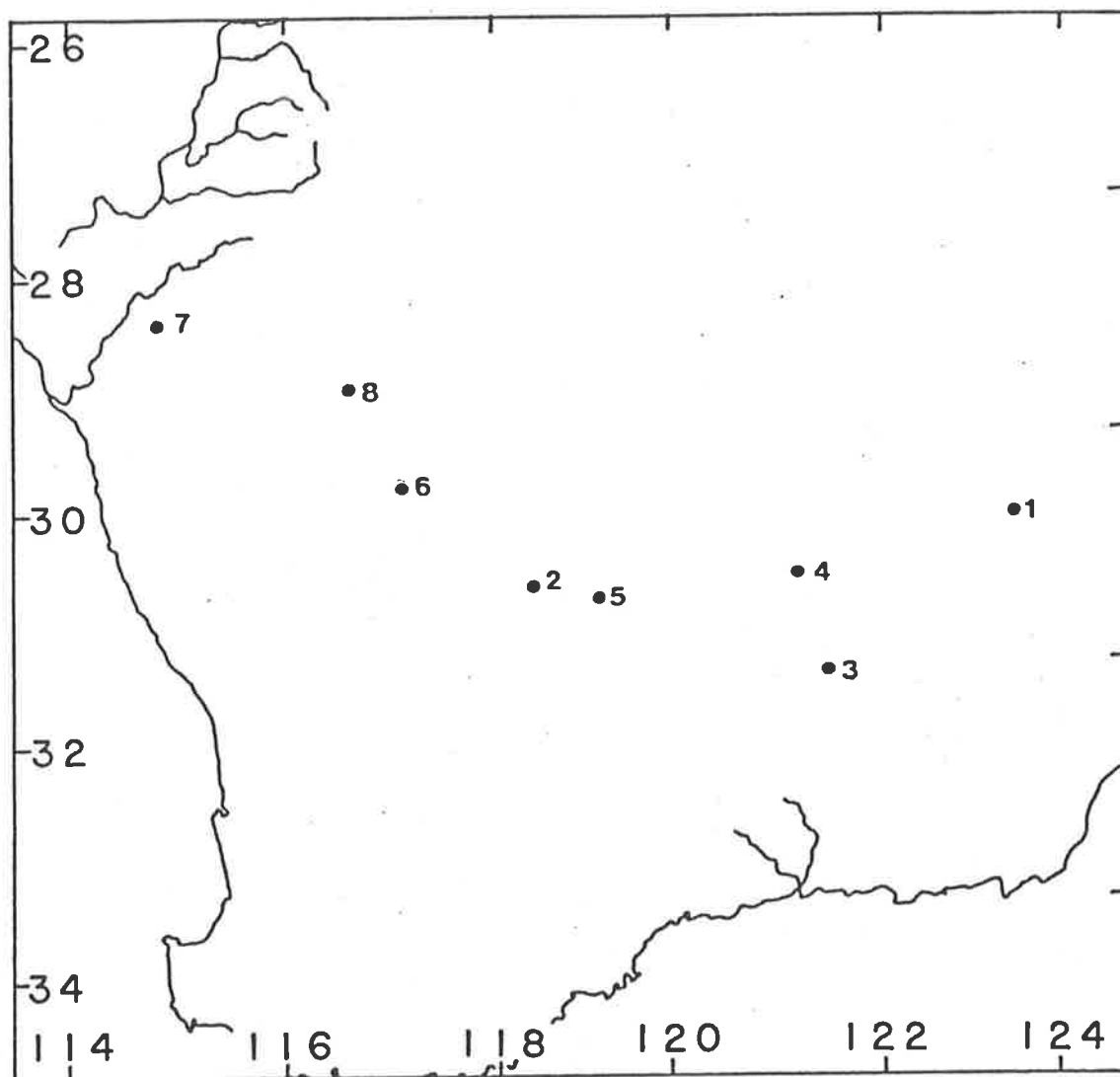


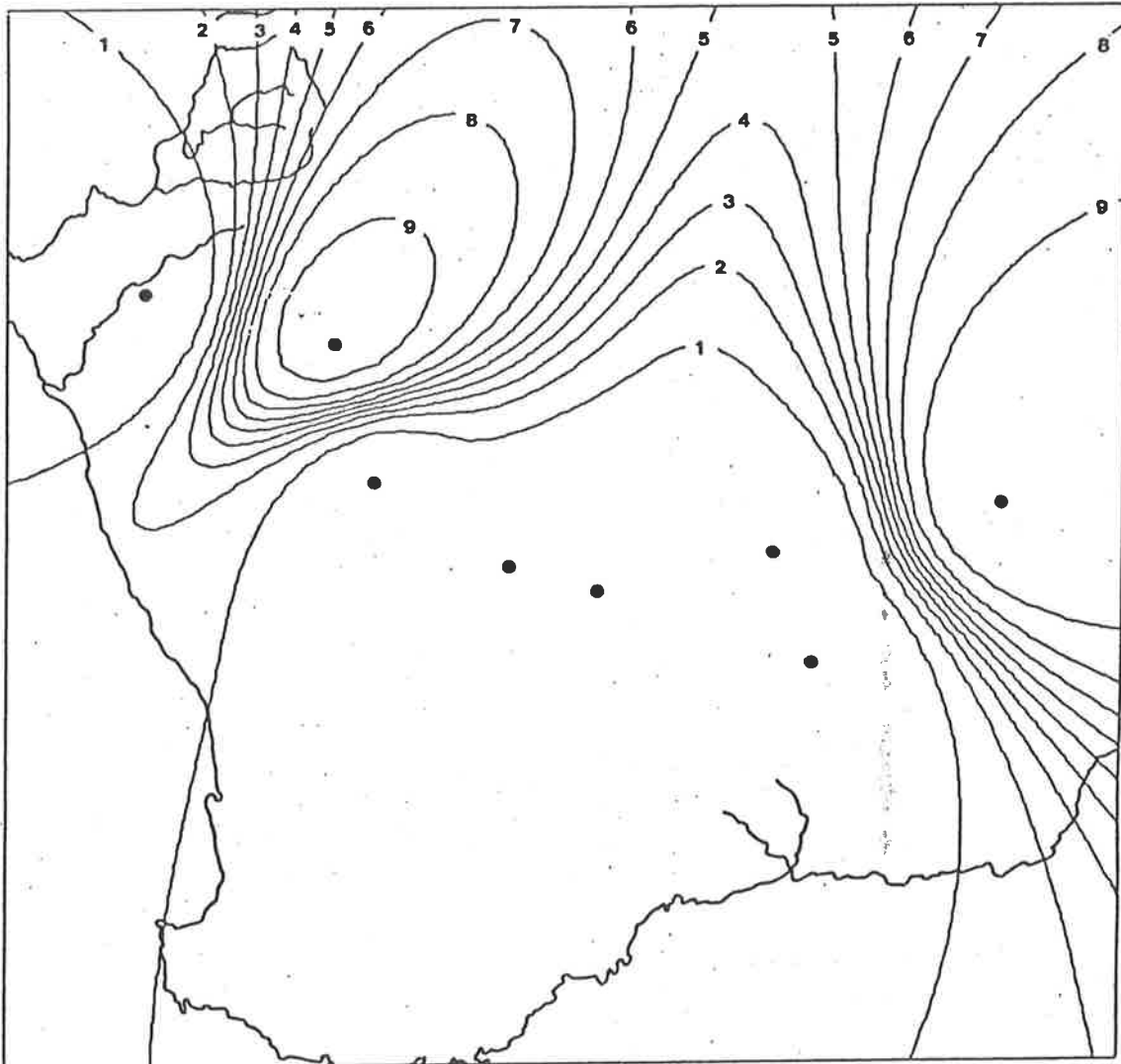
Fig. 34. Locality details of the 8 populations of the *P. laricoides* complex used for morphological variation studies. For further details of populations refer Table 10. A separate transparency of this figure is included inside the back cover to be used as an overlay on Figs 35 - 40.

Approximate locality of Population	Number of specimens/ Population
WESTERN AUSTRALIA	
1. Cundeelee	5
2. Campion	6
3. Lake Cowan	5
4. Kalgoorlie	6
5. Southern Cross	5
6. Mt Churchman	5
7. Pindar	7
8. Paynes Find	5

Table 11. Details of the 8 populations of the *P. laricoides* complex used for morphological variation studies.

1. Royce 5472	23. Wilson 3508
2. Royce 5371	24. Wilson 3515
3. Boswell F66	25. Chinnock 3132
4. Butler <i>s.n.</i>	26. Ashby 3585
5. Main <i>s.n.</i>	27. Blackall 3452
6. Beard 4744	28. Rosier 309
7. Canning CBG 26146	29. Rosier 251
8. Phillips CBG 23274	30. Weber 5188
9. Newbey 2538	31. Beard 5944
10. George 2670	32. Demarz 5261
11. Gardner 2060	33. Ashby 2993
12. Blackall 979	34. Ashby 3931
13. Burbidge 2664	35. Ashby 5112
14. Blackall 896	36. Ashby 5035
15. Gardner 2797	37. Maiden <i>s.n.</i>
16. Broadbent 1054	38. Phillips CBS 54467
17. Bale 123	39. Beard 6687
18. Kemsley <i>s.n.</i>	40. Burns 1037/2
19. Phillips CBG 23260	41. Alpin 2551
20. Lidgely 5 & 7	42. Steenbohm <i>s.n.</i>
21. Wilson 3112	43. Ashby 5209
22. Chinnock 3055	44. Ashby 5220

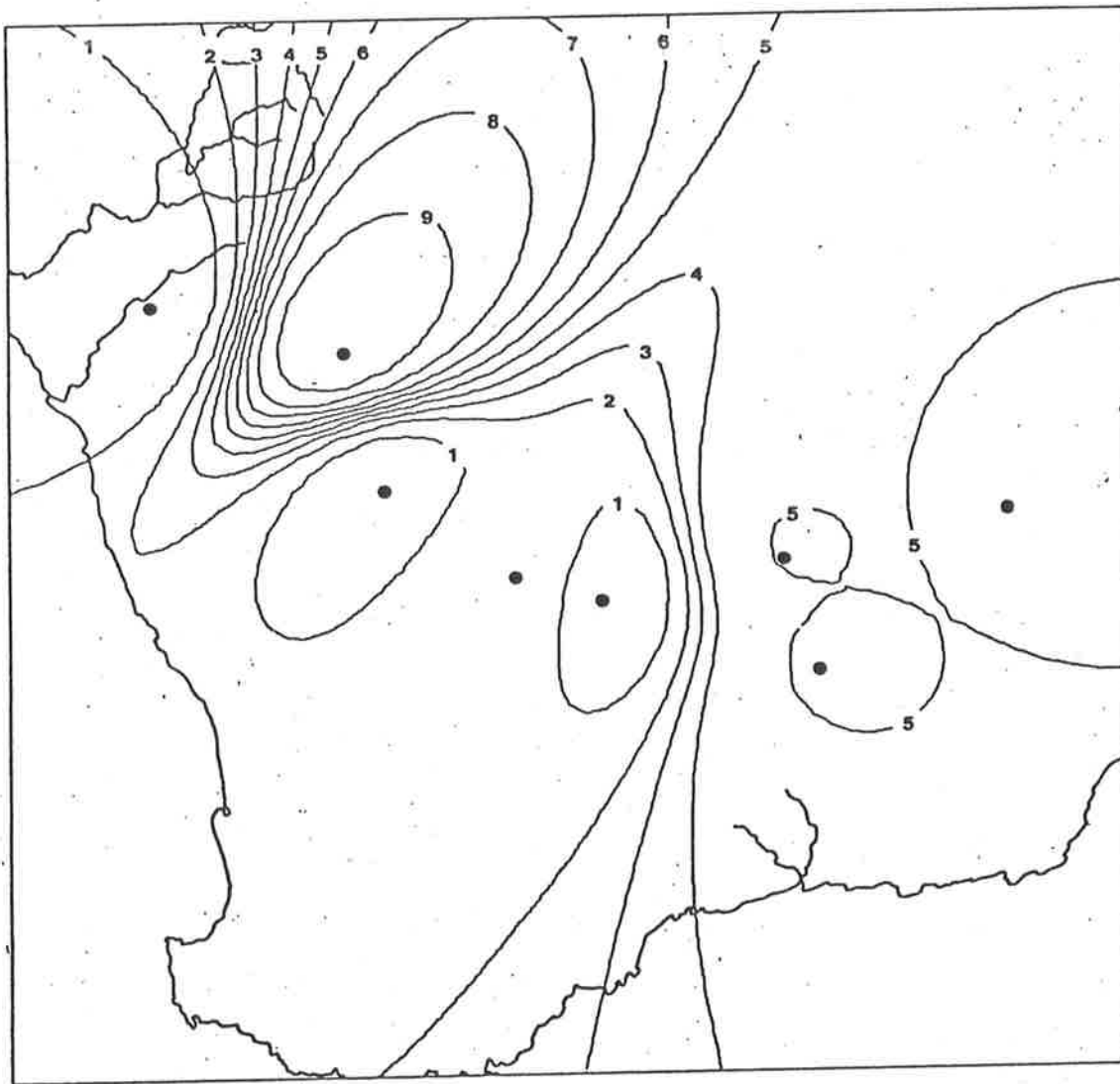
Table 12. Details of the 44 collections used in the study of morphological variation in the *P. laricoides* complex.



01 08 02 04 05 06 07 03

Fig. 35. Contour map (with summary of SNK test) of the anther appendage length (AAL) for populations of the *P. laricoides* complex.

Contour symbols and values are: 1 = 0.08; 2 = 0.24; 3 = 0.39;
4 = 0.55; 5 = 0.71; 6 = 0.87; 7 = 1.02; 8 = 1.18; 9 = 1.34.



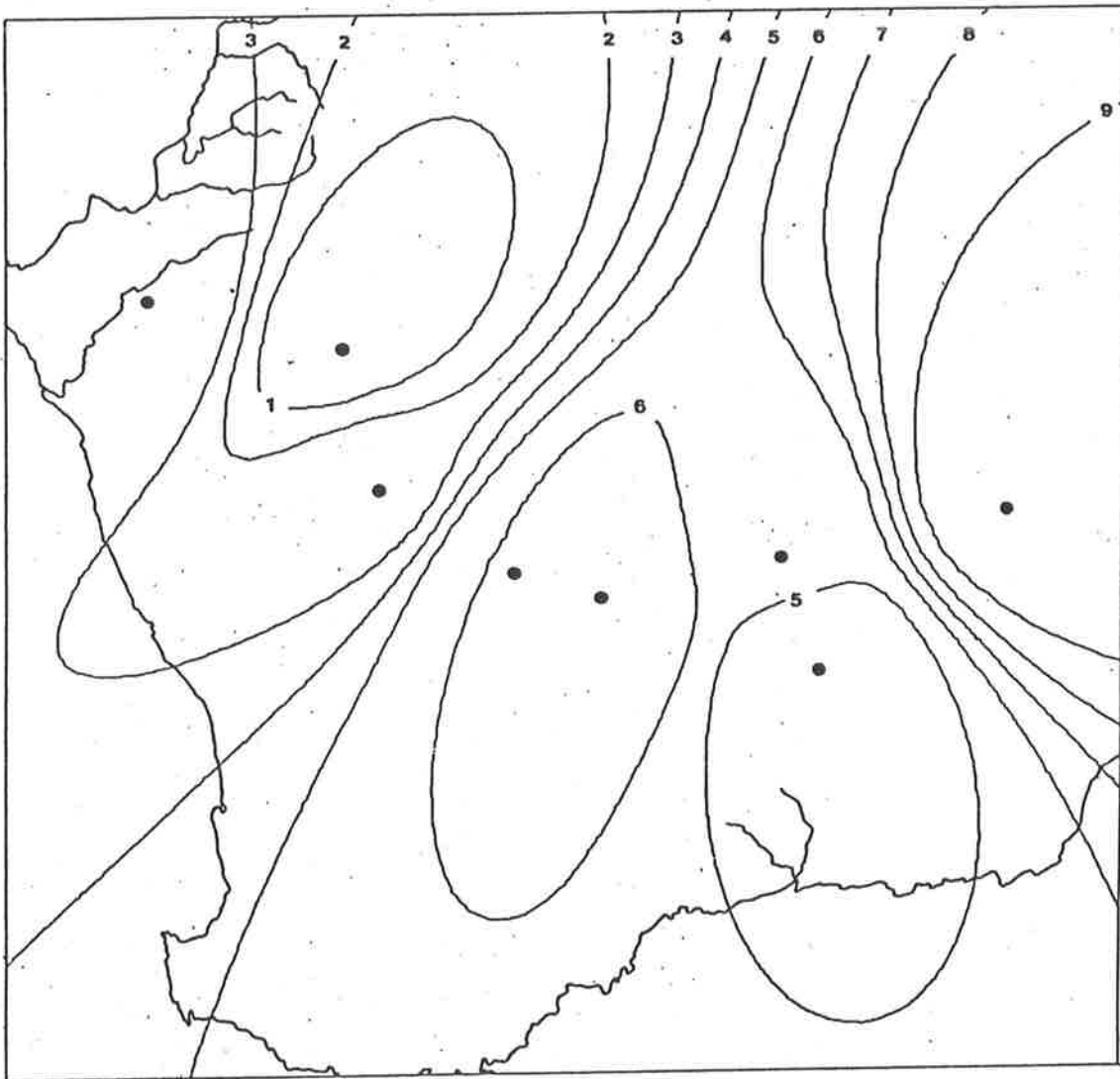
08 03 04 01 02 06 07 05

Fig. 36. Contour map (with summary of SNK test) of the position of the hairs on the branches (INTER) for populations of the *P. laricoides* complex. Contour symbols and values are: 1 = 0.11; 2 = 0.33; 3 = 0.55; 4 = 0.77; 5 = 0.99; 6 = 1.21; 7 = 1.43; 8 = 1.65; 9 = 1.87.

Another common type of pattern of geographic variation is illustrated by the length of the lamina - LL (Fig. 37). P. laricoides (1) has long leaves which are significantly different from all other populations. Populations 7 (P. pedicellata), 6 (P. semiteres ssp. intricata) and 8 (P. patens) have very short leaves. The other populations (2 - 5) have leaves of intermediate length between the two former groups. Other characters which have a similar pattern of variation include, the density of glands on the branches (STGD), the length to width ratio of the lamina (LLW), the density of glands on the outer surface of the calyx (KGDO), and the density of the glands on the lamina (LGD). In general, there is an east-west trend, such that population 1 (P. laricoides) has the largest values for the respective character, with populations 3 and 4 (P. incurvata), 5, 2 and 6 (P. semiteres), 8 (P. patens), and 7 (P. pedicellata) have progressively lower values.

The third common type is exemplified by the length of the pedicel - LP (Fig. 38). In this type of pattern of variation, there is a general west-east trend. The highest values for the respective character occurs in population 7 or 8, with the more easterly populations tending to have progressively lower values. Other characters with a similar pattern of variation are the length of the petiole to the length of the lamina (LPLL), calyx length (KL), and calyx lobe to tube ratio (KLLT).

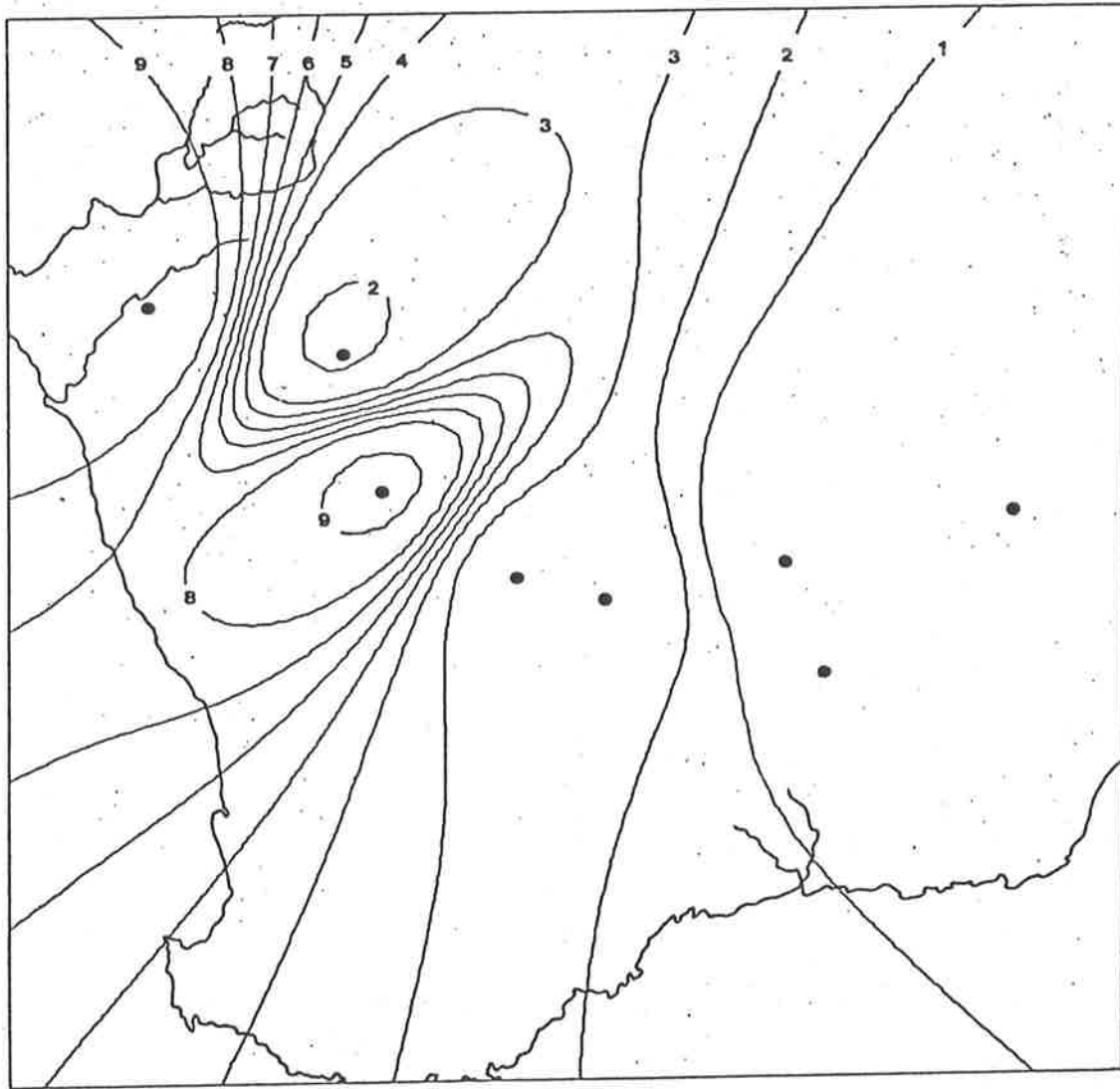
The final main type of geographic variation occurs for the length of the prophylls - BL (Fig. 39) and the length to width ratio of the prophyll (BLW). This type of pattern of variation is more or less opposite to the first type (refer Fig. 35). Populations 8 (P. patens) and 1 (P. laricoides) have short prophylls (Fig. 39) and small prophyll length to width ratios, while the other populations have long prophylls (Fig. 39) and large prophyll



01 05 02 04 03 07 06 08

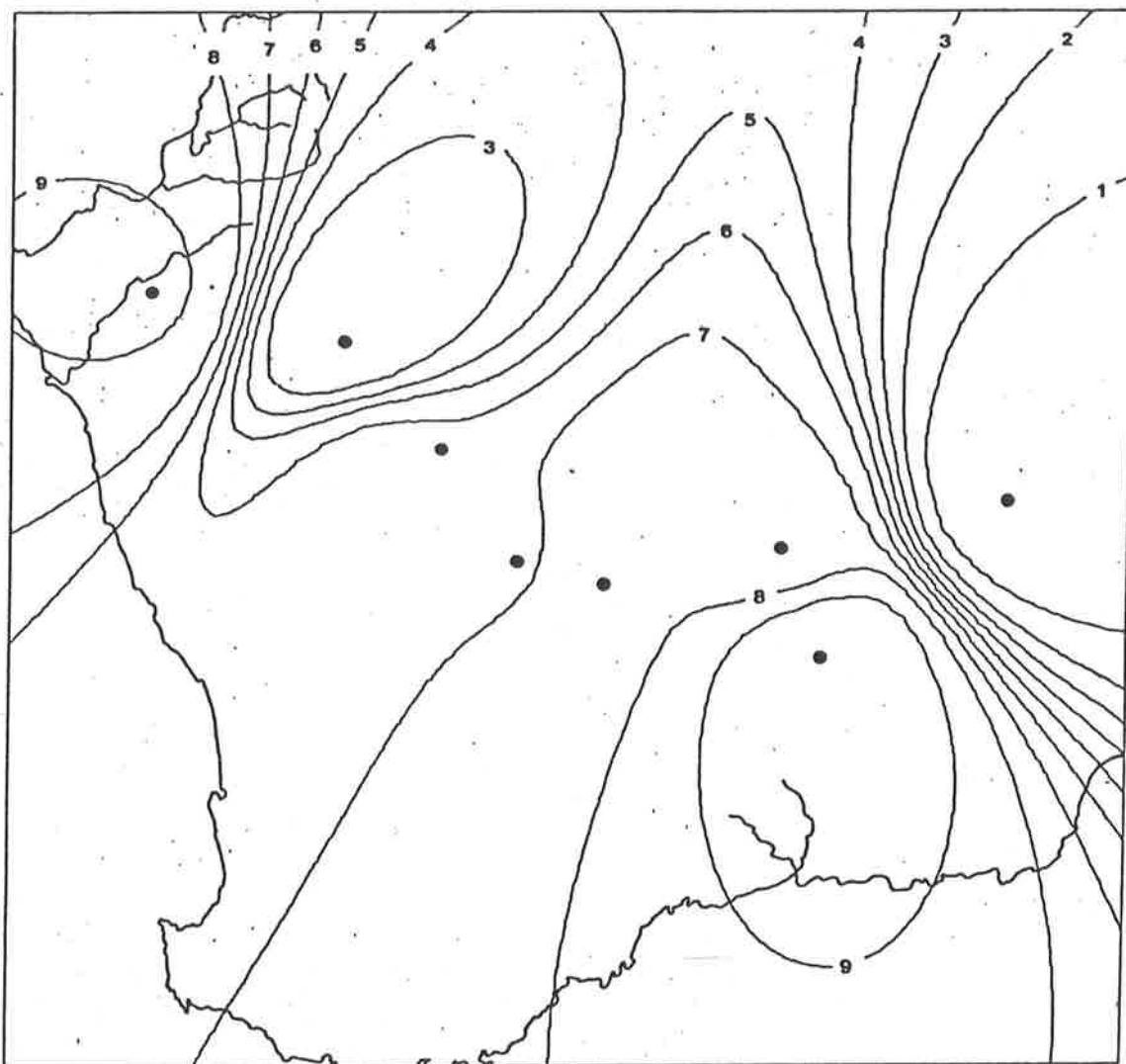


Fig. 37. Contour map (with summary of SNK test) of the lamina length (LL) for populations of the *P. laricoides* complex. Contour symbols and values are: 1 = 2.39; 2 = 3.71; 3 = 5.03; 4 = 6.35; 5 = 7.66; 6 = 8.98; 7 = 10.30; 8 = 11.62; 9 = 12.94.



07 06 02 05 08 03 01 04

Fig. 38. Contour map (with summary of SNK test) of the pedicel length (PL) for populations of the *P. laricoides* complex. Contour symbols and values are: 1 = 2.79; 2 = 3.31; 3 = 3.83; 4 = 4.35; 5 = 4.87; 6 = 5.39; 7 = 5.91; 8 = 6.43; 9 = 6.95.



03 07 05 04 02 06 08 01

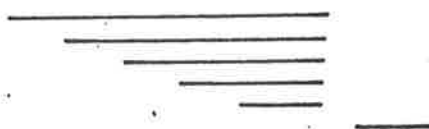


Fig. 39. Contour map (with summary of SNK test) of the prophyll length (BL) for populations of the *P. laricoides* complex. Contour symbols and values are: 1 = 5.11; 2 = 5.36; 3 = 5.62; 4 = 5.88; 5 = 6.13; 6 = 6.39; 7 = 6.64; 8 = 6.90; 9 = 7.16.

length to width ratios.

The composite differential formed from the 19 characters which showed both a significant F-test and a significant SNK test (both at the 0.01 level) is presented in figure 40. The most rapid areas of change occur between (i) P. laricoides (1) and P. incurvata (3 & 4), (ii) P. incurvata and P. semiteres (2, 5 & 6), (iii) P. patens (8) and all other populations, (iv) P. pedicellata (7) and all other populations.

The interpretation of the various surface trend analyses and the composite differential is severely limited by the small number of individuals (44) included in this study and by the lack of field information. For example, it is not known if the populations represent interbreeding units. Most populations, as defined by this study, are very heterogenous (Fig. 17) and additional collections may weaken the distinctness of some populations.

The prostantheras of this region are under-collected, but the present collection localities of the populations may more or less represent their actual distribution. If this is so, the disjunctions assumed may exist. Based on field-label information (which is very inadequate), Sheets 5 and 10 - SW Sheet (Atlas of Australian Soils, Division of Natl. Mapping, Dept. Natl. Development, Canberra, 1968) and Stace, et al. (1968), all taxa appear to be confined to light soils which are usually sandy to sandy-loam. P. laricoides occurs in red sands; P. incurvata occurs in shallow calcareous loamy soils (near Kalgoorlie) and in brown calcareous earths (near Lake Cowan); P. semiteres ssp. semiteres occurs in yellow earths; P. patens occurs in shallow earthy loams; and P. pedicellata occurs in yellow-brown earths with ironstone gravel on surface. The distribution of soils may represent an important factor controlling the distribution of these taxa. It is of interest to

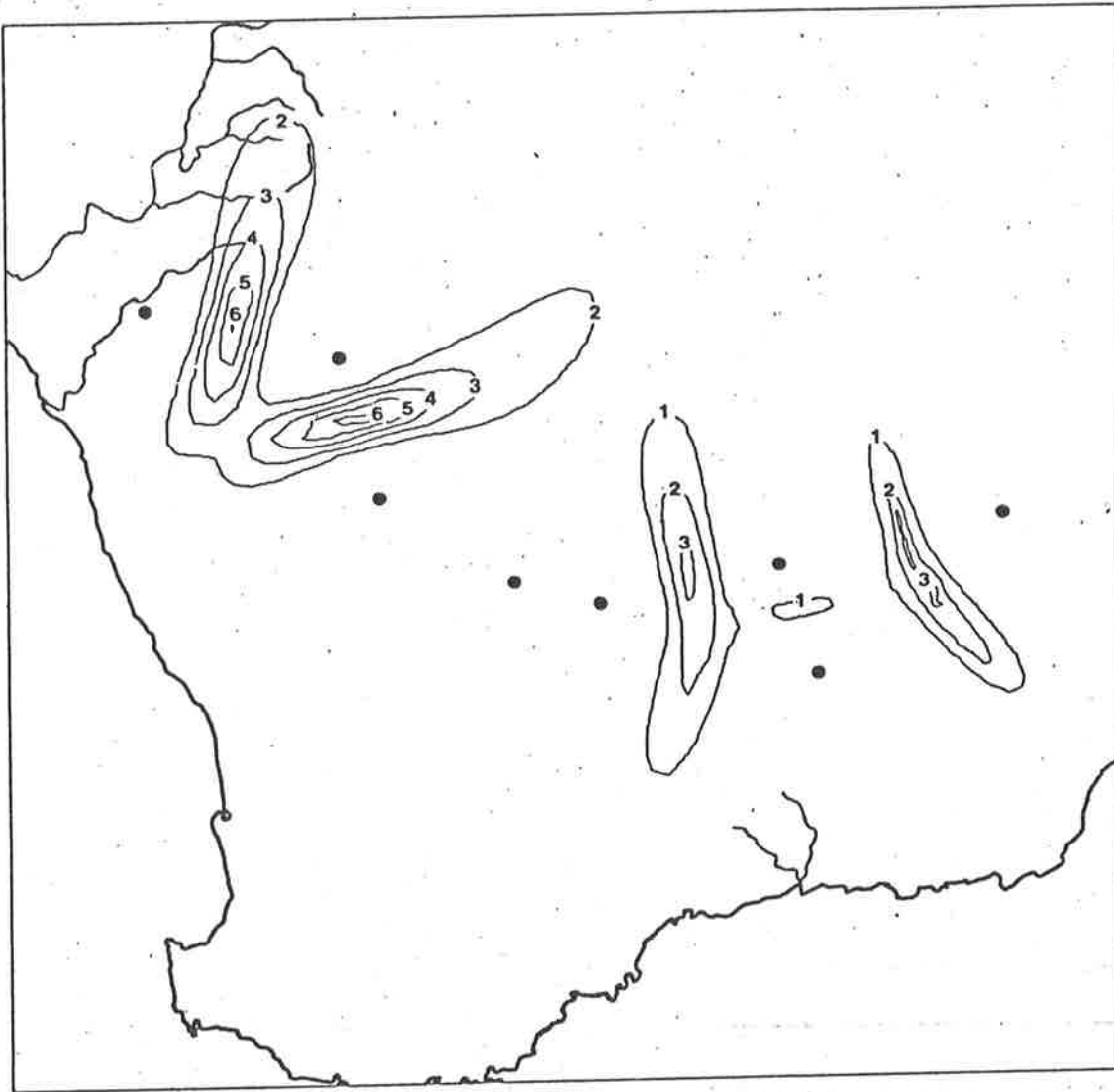


Fig. 40. The composite differential formed from 19 characters in populations of the *P. laricoides* complex. Contour symbols and values are: 1 = 0.04; 2 = 0.10; 3 = 0.16; 4 = 0.22; 5 = 0.27; 6 = 0.33.

note that P. pedicellata and P. semiteres spp. intricata, which both have long pedicels, occur in yellow to yellow-brown earths.

Without further field information, climatic data does not appear to suggest useful hypotheses to explain the composite differential (Fig. 40). These taxa occur in the Arid Moisture region (Gentilli 1972) (populations 2, 3, 5 - 8 with phytohydroxeric indices between 3 and 5, populations 1 and 4 with phytohydroxeric indices between 2 and 3). Although it is tempting to suggest that P. laricoides (1) may, at least in part, be distinct because it occurs in a subdesert (Gentilli 1972) interzone between PerArid and Arid Moisture regions, it is noted that it has been collected from amongst rocks. This taxon may be sufficiently sheltered to avoid the harshness of the subdesert interzone, such that the microclimate may be similar to that of the other populations (2 - 6).

Conclusions from geographic variation studies

In the three previously discussed studies I have used geographic variation analysis in two ways. In the study of the P. aspalathoides complex I used the various techniques to study the variation within a single species, whereas in the latter two complexes (P. calycina-P. microphylla-P. serpyllifolia, P. laricoides) more than one species was involved in each. Gould & Johnston's (1972) three main aims of geographic variation studies are presented on page 82. With respect to my work, the first two aims have been accomplished. The actual pattern of morphological variation has been established in all three complexes. This has made it possible to suggest and test (subjectively) possible causes for these patterns. Climatic and environmental conditions have been proposed as causal factors influencing the observed morphological variation in P. aspalathoides, P. calycina and P. serpyllifolia. However, there appears to be relatively little climatic and/or environmental differentiation which could explain the morphological variation observed in the P. laricoides complex. Detailed field infor-

mation on this latter complex is required.

Gould and Johnston's (1972) third aim (viz. 'to determine if any trends of evolution or speciation are implied by such patterns of variation') is more difficult to accomplish. For instance, one of the main problems is the determination of the evolutionary significance of the morphological differences observed between taxa. This is particularly relevant in this study where character differences are quantitative and so may be of reduced evolutionary significance.

Since the Kangaroo Island populations of both P. aspalathoides and P. serpyllifolia are relatively distinct from their respective mainland populations, this suggests that these populations may be genetically drifting away from the mainland populations. However, it is not possible to hypothesize on the possible mode of speciation or to provide further insights into the lines of migration of these species because insufficient information was provided by the geographic variation analyses. With respect to the P. laricoides complex, no obvious trends of speciation or lines of migration were detected.

VOLATILE OILS (TERPENOIDS)

Volatile oils are valid taxonomic characters (von Rudloff, 1975) which have proved useful in various studies. They have been successfully used in the study of specific and infraspecific variation (e.g. Adams 1970b, 1972a; Adams & Turner 1970; Emboden & Lewis 1967; Flake et al., in Runeckles & Mabry 1973; Hefendehl & Murray 1972; Turner 1970; von Rudloff 1967, 1972a, 1973, 1975; Whiffin 1978; Zavarin & Snajberk 1973), and in the detection of hybrids (e.g. Whiffin 1977, 1981; Zavarin et al. 1969). They have also proved to be a convenient, accurate and a significant source of data which can be used to characterize individuals or populations. Although there is some subjectivity in the choice of the method of extraction and analysis, the final data are essentially, objectively derived.

The biosynthesis of volatile oils is relatively unknown, although significant advances have been made by a number of workers (refer Loomis & Croteau, in Runeckles & Mabry 1973). Similarly the mechanism of genetic control has not been fully clarified. In general, the inheritance of most compounds appears to be under the control of one or a few genes (e.g. Irving & Adams, in Runeckles & Mabry 1973). Hanover (1966a) and von Rudloff (1972a) have shown that environmental factors have little or no effect on the composition of the volatile oils. However, the actual amount of oil produced may be influenced by such factors.

Materials and methods

The amount and composition of the oil produced is affected by the maturity of the leaves (Adams & Hagerman 1976; Firmage & Irving 1979; Hanover 1966a; Maarse & Kepner 1970; von Rudloff 1972b; Zavarin et al. 1971), and may also be affected by seasonal variation (e.g. Adams 1970a;

Attaway et al. 1967; Maarse & Kepner 1970; Powell & Adams 1973; von Rudloff 1967, 1972b; Zavarin et al. 1971). To minimise such affects, all samples were collected during mid- to late 'spring' (September - early November). Spring is here defined as the season when mature flowers are common throughout the population being sampled. Therefore, collections from Kangaroo Island in November, are regarded as comparable to collections from lower latitudes in September. Adams (1970a), Cheng & von Rudloff (1970), and other workers, recommend that chemosystematic studies should be carried out during autumn and winter because this is the period in which the oil composition is most stable. For various reasons, this was not possible and so great care was taken to ensure that only the previous seasons mature (c. 1 year old) leaves were sampled. To minimize diurnal effects (Adams & Hagerman 1977, Adams 1979) most collections were made between 10 a.m. and 1 p.m.

Fresh foliage samples from each plant were sealed in polyethylene bags, kept as cool as possible until air-freighted to Adelaide, where they were stored at approximately 2°C until processed. Since the samples were kept at low temperatures none were apparently affected by 'sweating' (Penfold & Willis, 1961).

Fresh foliage (10 - 30 g) was steam distilled in an all-glass apparatus (modification of Forss & Holloway 1967). The oil was extracted and concentrated according to Whiffin (1978), except that the oil was extracted into ether instead of freon11. Oil samples were concentrated with a jet of high-purity nitrogen and stored under that gas in sealed vials at -20°C until analysed.

The oils were analysed on a Perkin Elmer 900 gas-liquid chromatograph, using 15 m x 0.5 mm i.d. FFAP coated stainless steel SCOT columns with He

(at 2.5 psi) as carrier gas. Individual runs (with injection size 0.3 μ l) were held at 80°C for 3 min., then temperature programmed from 80 to 170°C at 6°/min., and finally held at 170°C for 30 min. Gas flow rates for the flame-ionization detector were: Air 30 psi; H₂ 22 psi. Individual components were identified by their retention times and by co-injection with authentic compounds. A Hewlett Packard 3370A Integrator was used to determine percentage compositions.

Each individual component of the volatile oils was assigned a unique number by superimposition of the chromatograms and by comparison of retention times. Adams (1972b) regards the errors resulting from miscomparison as only slightly affecting comparisons between taxa. The retention times of α - Terpineol and Limonene, checked after each run, were used as standards. Thirty-seven consistently separable components were obtained. Since it is often difficult to determine whether a compound is present in trace amounts or absent (Southwell 1973), all variation in the data is regarded as quantitative rather than qualitative. Those components which were present in amounts less than 0.1% of the total oil were called 'traces' (refer Table 13) and were given an arbitrary value of 0.1%. Since the biogenesis of unknown compounds can not be known, there is a very real danger that some characters ('peaks') may represent one biogenetical system (Weimarck 1972), whereas others may represent several independent systems. Therefore, even though some characters may be highly correlated because they belong to the one biogenetical pathway, they will receive equal 'weighting' with other characters in the various numerical analyses. Although I was unable to avoid the effects of the above type of character correlation, because the biogenetic pathways are now known for Prostanthera, only those chemical characters whose identity had been verified, at least

COMPOUND	POPULATIONS					
	1	2	3	4	5	6
1. α - Pinene	tr	0.4	4.3	0.8	2.4	1.4
2. β - Pinene	0.8	2.9	9.98	0.9	4.7	4.2
3. $C_{10}H_{16}$	0.4	0.7	0.48	0.8	2.6	0.4
4. $C_{10}H_{16}$	0	0.7	0.3	0	0	0
5. Limonene	0.7	0.78	3.1	0.4	1.3	0.5
6. 1,8-Cineole	33.5	41.3	45.2	41.1	41.0	29.4
7. ρ - Cymene	2.9	0.9	0.4	1.0	1.1	0.6
8. $C_{10}H_{14}O$	1.0	1.2	0.3	0.1	0.1	0.4
9. $C_{10}H_{18}$	1.4	0.6	0.8	0.1	0.1	0.6
10. Terpinen-4-ol	0.7	0.9	0.5	1.0	1.1	1.2
11. $C_{10}H_{14}O$	0.9	2.1	1.2	0.4	0.1	1.1
12. $C_{10}H_{16}O$	0.9	2.7	0	0.2	0.6	0.3
13. $C_{15}H_{24}$	6.8	4.7	2.7	4.4	3.1	1.4
14. $C_{15}H_{24}$	0.3	0.6	0	0.2	0.1	0.2
15. $C_{10}H_{16}O$	0.7	1.8	0.3	1.0	0.1	0.6
16. α - Terpineol	1.2	3.7	0.7	2.9	0.6	0.4
17. $C_{10}H_{18}O$	3.7	0.4	0.6	1.1	0.1	0.4
18. $C_{15}H_{24}$	1.0	0.7	1.3	0.5	0.5	0.5
19. $C_{10}H_{16}O$	0.4	1.9	1.2	0.6	0.6	3.3
20. $C_{10}H_{14}O$	tr	0.3	0.4	0.4	0.1	0.2
21. Maaliol	34.0	0.2	tr	8.7	1.8	0.3
22. $C_{15}H_{26}O$	3.5	3.5	0.5	4.2	4.6	8.8
23. Globulol	2.1	5.2	4.5	2.2	3.6	6.7
24. Viridiflorol	0.4	0.8	1.0	5.6	11.1	2.2
25. $C_{15}H_{22}O$	0.3	0.1	tr	0.2	0.1	0.3
26. $C_{15}H_{24}O$	0.4	0.4	1.3	1.1	0.1	0.5
27. $C_{15}H_{26}O$	0.3	16.5	tr	0.3	0	0.01

Table 13. Mean % composition of selected volatile leaf oils of *P. aspalathoides*.

tentatively (using the previously discussed techniques), were used in subsequent analyses (Table 13). My final volatile leaf-oil character set is based on that used by Lassak (1980).

NUMERICAL ANALYSES OF VOLATILE LEAF-OILS OF *PROSTANTHERA ASPALATHOIDES*

The volatile leaf oils of forty-four individuals of *P. aspalathoides* were sampled (refer figure 44 for details of specimens). The location of these populations is shown in figure 41, with further details in Table 14.

Evaluation of volatile leaf-oil character set

Most characters (70.4%) were nonparametrically distributed. Kurtosis and Skewness values are presented in Table 15. All characters appear to provide a high level of 'uniqueness' with respect to their information content ($-0.60 < \text{Kendall's tau} < + 0.60$, Table 16). The first three axes (factors) of principal factor analysis account for 48% of the variance. Those characters with high scores on these three factors are summarized in Table 17. Characters 8, 11 - 16 and 27 tend to cluster in the plot of factor 1 versus factor 2 (Fig. 42), scoring high on factor 1 (Table 17), but low on all other factors. Characters 1, 2, 4, 5 and 7 loosely cluster in the plot of factor 2 versus 3 (Fig. 43), scoring high on factor 2 (Table 17). It can also be seen that characters 9, 13, 17 and 21 have high positive scores (Fig. 43, Table 17).

Numerical analyses of specimens

Whiffin (1982) suggests that volatile oil data sequentially standardized by standard deviation is marginally better than standardization by range. However, since both are useful, the latter procedure was used so as to conform with that used on the morphological data (p. 64). The

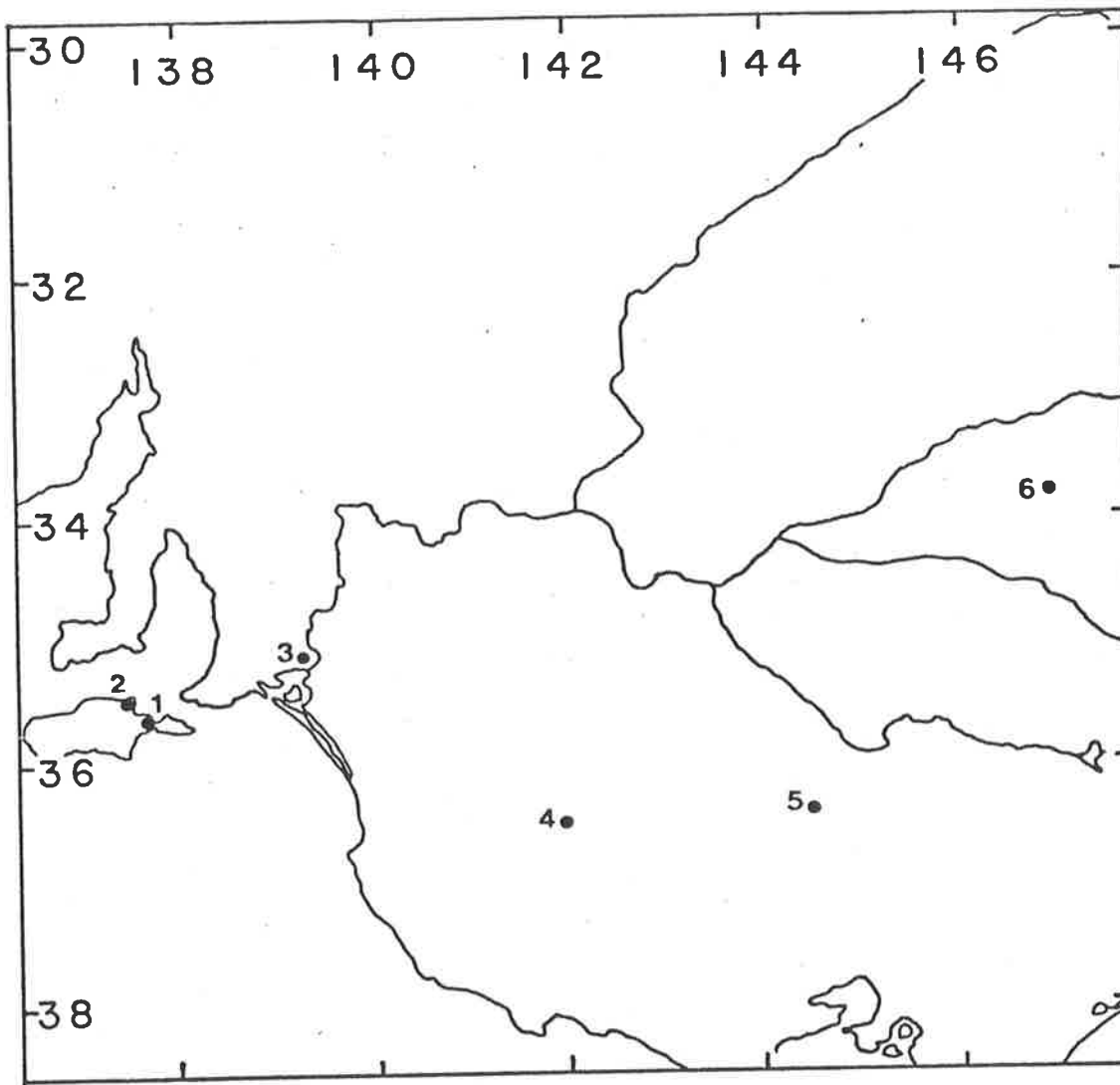


Fig. 41. Locality details of the 6 populations of *P. aspalathoides* used for volatile leaf oil variation studies. For further details of populations refer Table 14. A separate transparency of this figure is included inside the back cover to be used as an overlay on Figs 47

POPULATION	NUMBER OF SPECIMENS/POPULATION
SOUTH AUSTRALIA	
1. American River	3
2. Kingscote	22
3. Braendler's Scrub	3
VICTORIA	
4. Little Desert	4
5. Bendigo	5
NEW SOUTH WALES	
6. Rankin Springs	7

Table 14. Details of the 44 collections used in the study of the volatile leaf oil variation of *P. aspalathoides*.

Character	Kurtosis	Skewness.
1. α -Pinene	5.45	2.23
2. β -Pinene	9.63	2.67
3. $C_{10}H_{16}$	1.34	1.12
4. $C_{10}H_{16}$	3.74	1.12
5. Limonene	6.64	2.17
6. 1,8-Cineole	-0.85	-0.56
7. p -Cymene	2.07	1.32
8. $C_{10}H_{14}O$	-1.23	-0.10
9. $C_{10}H_{18}$	0.21	0.74
10. Terpinen-4-ol	18.44	3.74
11. $C_{10}H_{14}O$	-0.36	0.14
12. $C_{10}H_{16}O$	-1.33	0.13
13. $C_{15}H_{24}$	-0.05	-0.14
14. $C_{15}H_{24}$	1.54	1.07
15. $C_{10}H_{16}O$	-1.30	-0.04
16. α -Terpineol	-0.45	0.69
17. $C_{10}H_{18}O$	11.04	3.26
18. $C_{15}H_{24}$	5.35	1.81
19. $C_{10}H_{16}O$	33.91	5.58
20. $C_{10}H_{14}O$	-0.18	0.93
21. Maaliol	9.80	3.17
22. $C_{15}H_{26}O$	26.21	4.69
23. Globulol	3.83	1.54
24. Viridiflorol	4.57	2.42
25. $C_{15}H_{22}O$	8.13	2.79
26. $C_{15}H_{24}O$	2.61	1.58
27. $C_{15}H_{26}O$	-1.24	0.67

Table 15. Kurtosis and skewness values for 27 volatile leaf oil compounds of *P. aspalathoides*.

CHARACTER-PAIR	KENDALL'S TAU
C1 — C2	0.4907
C2 — C5	0.5751
C2 — C7	0.5061
C4 — C20	0.4910
C8 — C11	0.5064
C8 — C12	0.5623
C8 — C14	0.6018
C8 — C16	0.5204
C8 — C19	0.5198
C11 — C19	0.5117
C12 — C15	0.5761
C12 — C16	0.5954
C12 — C27	0.5922
C15 — C16	0.5484
C16 — C27	0.5586

Table 16. Correlation coefficients for selected character-pairs (Kendall's tau) for volatile leaf oils of *P. aspalathoides*.

FACTOR 1		FACTOR 2		FACTOR 3				
12.	$C_{10}H_{16}O$	0.887	18.	$C_{15}H_{24}$	0.798	21.	Maaliol	0.742
15.	$C_{10}H_{16}O$	0.828	2.	β -Pinene	0.725	17.	$C_{10}H_{18}O$	0.651
27.	$C_{15}H_{26}O$	0.768	5.	Limonene	0.643	6.	1,8-Cineole	-0.613
8.	$C_{10}H_{14}O$	0.744	4.	$C_{10}H_{16}$	0.610	9.	$C_{10}H_{18}O$	0.575
1.	α -Pinene	-0.738	23.	Globulol	0.519			
16.	α -Terpineol	0.729	26.	$C_{15}H_{24}O$	0.511			
11.	$C_{10}H_{14}O$	0.629						
14.	$C_{15}H_{24}$	0.624						
13.	$C_{15}H_{24}$	0.534						
5.	Limonene	-0.518						

Table 17. Volatile leaf oil compounds with high factor scores on the first three extracted factors from Principal factor analysis.

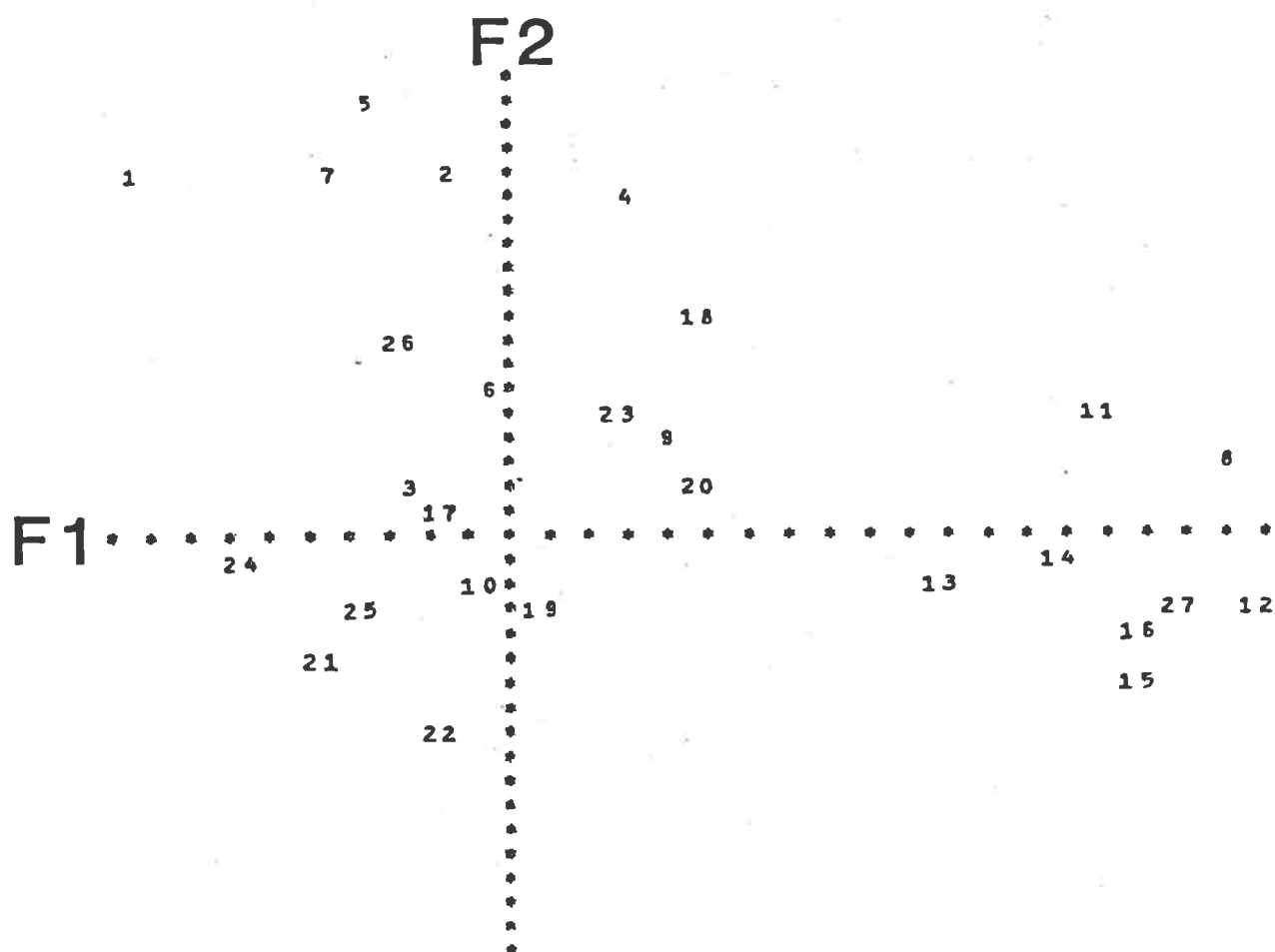


Fig. 42. Principal factor plot (function 1 versus function 2) of the volatile leaf oils of *P. aspalathoides*. For further details of volatile leaf oils refer Table 15.

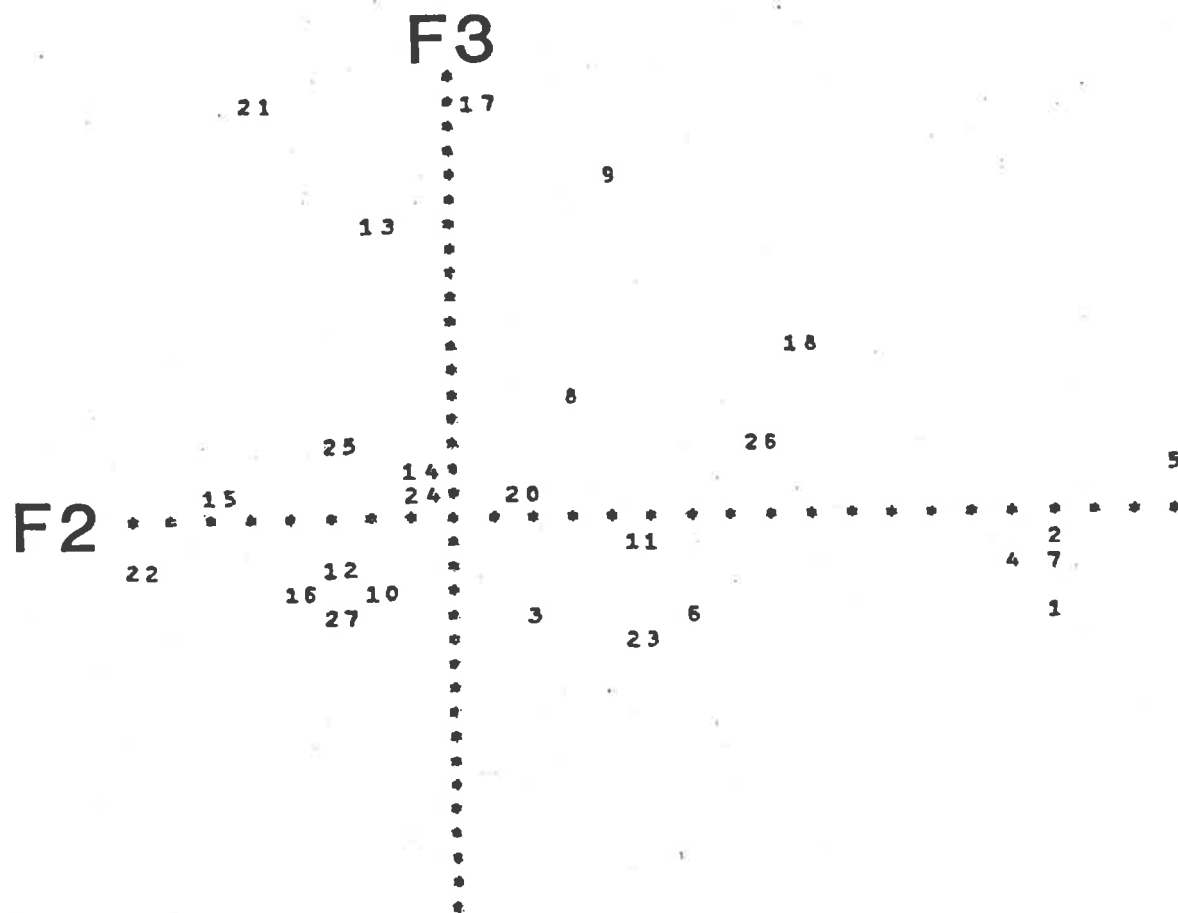


Fig. 43. Principal factor plot (function 2 versus function 3) of the volatile leaf oils of *P. aspalathoides*. For further details of the volatile leaf oils refer Table 15.

nearest-neighbour phenogram of 41 individual specimens (based on a matrix of Manhattan metric distances of the full data set) is presented in figure 44. The most striking feature of this phenogram is the within-population heterogeneity. The Kingscote population (2) (viz. Conn 1047) has the Little Desert population (4) (viz. Conn 697) as its nearest neighbour (Fig. 44), not the American River population (1) as might be expected. However, the American River population has the Kingscote population as its second nearest neighbour. The American River population (viz. Conn 1067) has Conn 694 (of the Little Desert population) as its nearest neighbour (Fig. 44). The Rankin Springs population (6) has its closest relationship with the Little Desert population (4), then to Bendigo (5), and finally with Braendler's scrub (3).

The first four axes of the principal coordinate analysis account for 68.33% of the total variation. Therefore, these ordinations provide a useful simplification of the data. In the plots of function 1 versus function 2 (Fig. 45), and function 1 versus function 3 (Fig. 46), the Kingscote population (2) forms a distinct cluster, separate from all other populations. The American River population (1) is distinct from all populations on several functions (e.g. Fig. 45), but on others (e.g. Fig. 46) it is closely related to the mainland populations. The Rankin Springs population (6) usually forms indistinct clusters. The Bendigo population (5) has its closest relationship with the Rankin Springs population and is usually distinct from the other mainland populations (3 & 4). Overall, the mainland populations are weakly clustered on most functions such that they do not form easily separable population-based clusters.

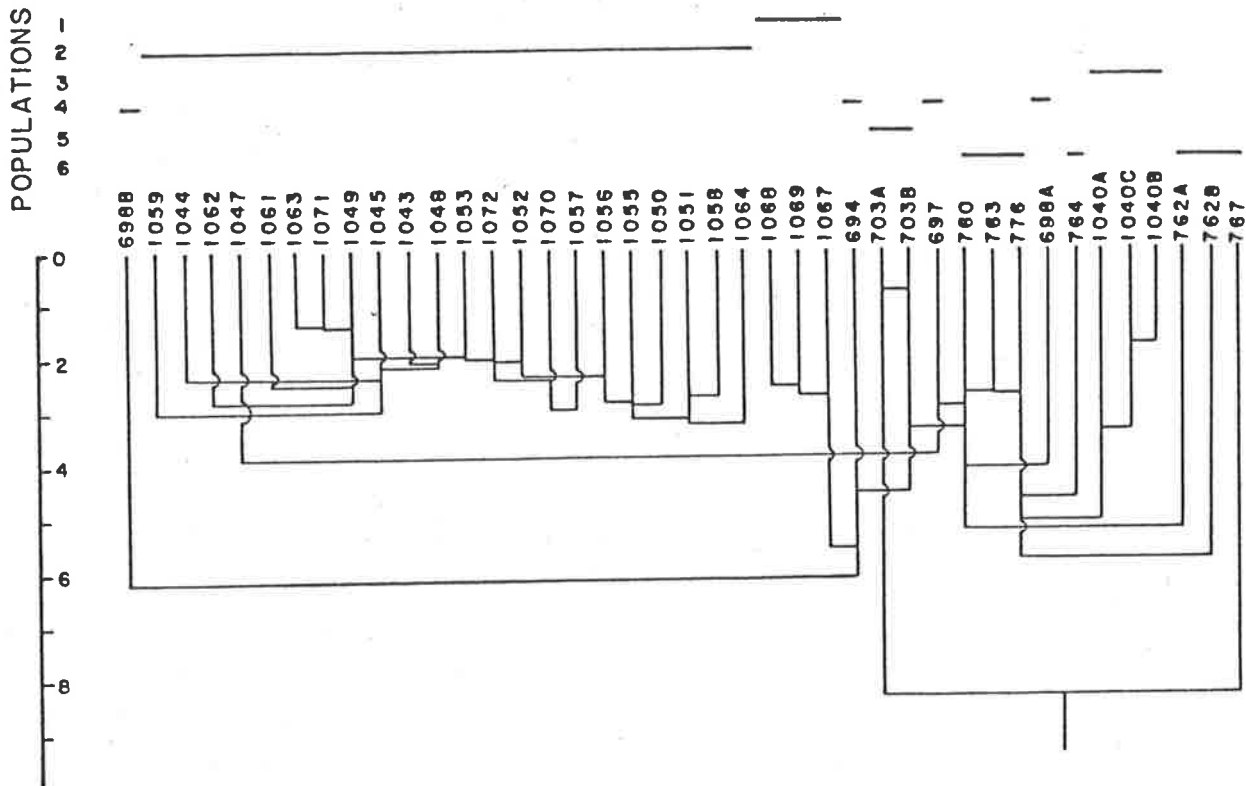


Fig. 43. Nearest neighbour phenogram generated from the Manhattan distance matrix of 41 specimens of *P. aspalathoides* (based on the volatile leaf oils). The collection numbers given immediately above the phenogram were all collected by the author. The horizontal lines above the phenogram group the specimens into their respective populations (for further details of populations refer Table 14).

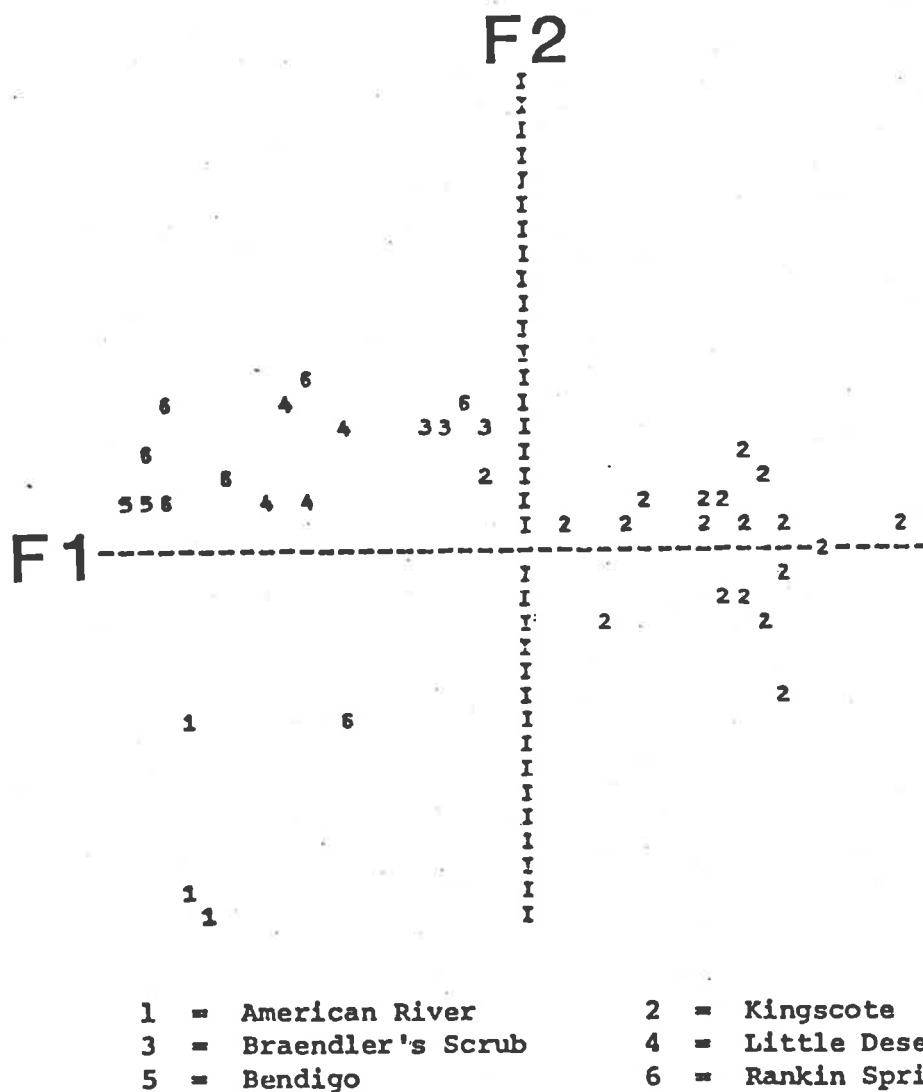
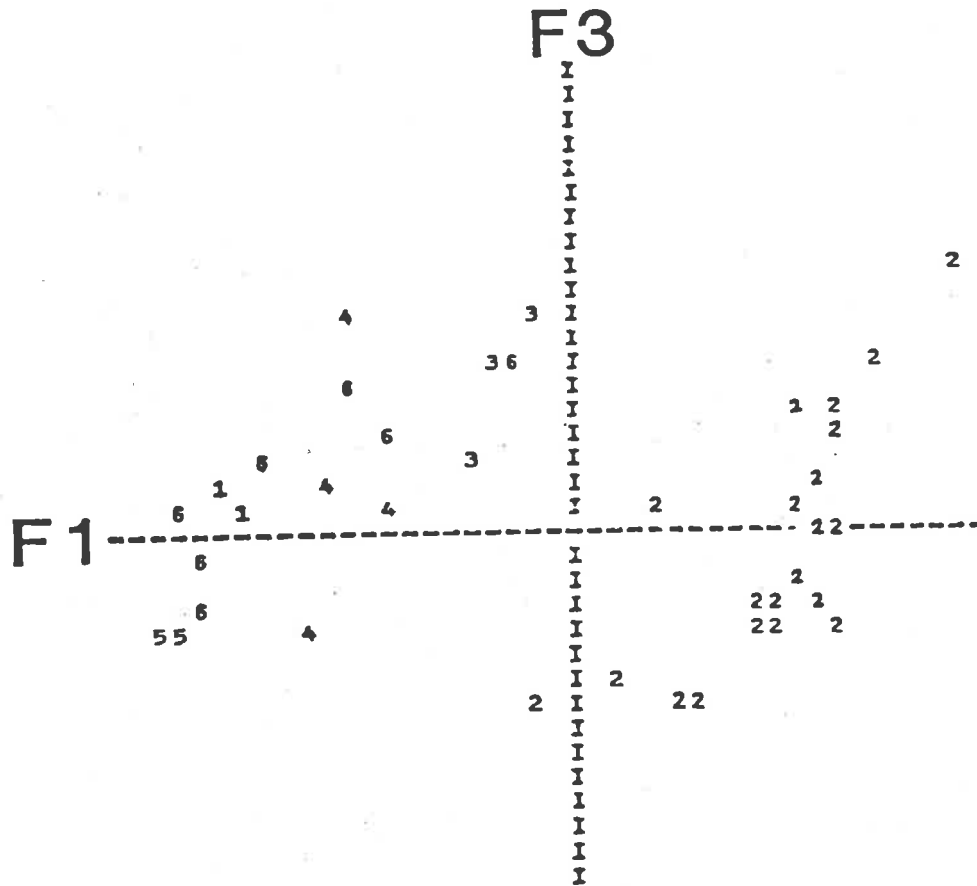


Fig. 45. Principal coordinate plot (function 1 versus function 2) of the *P aspalathoides* populations (based on volatile leaf oils). For further details of populations refer Fig. 41 and Table 14.



- | | |
|-----------------------|--------------------|
| 1 = American River | 2 = Kingscote |
| 3 = Braendler's Scrub | 4 = Little Desert |
| 5 = Bendigo | 6 = Rankin Springs |

Fig. 46. Principal coordinate plot (function 1 versus function 3) of the *P. aspalathoides* populations (based on volatile leaf oils). For further details of populations refer Fig. 41 and Table 14.

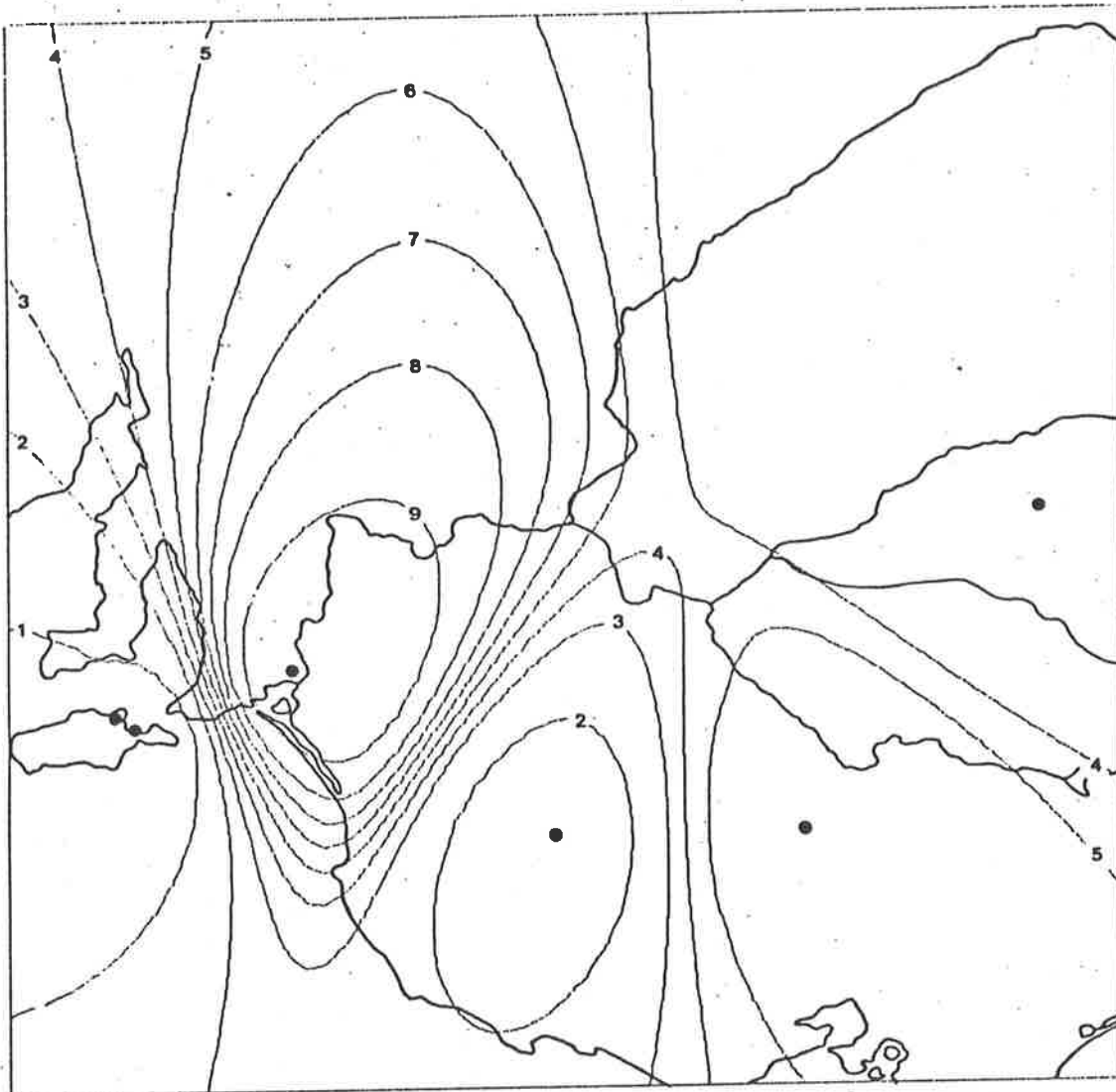
GEOGRAPHIC VARIATION OF PROSTANTHERA ASPALATHOIDES
 BASED ON VOLATILE LEAF-OILS

Of the original 27 characters, 18 showed both a significant F -test and a significant SNK test (both at the 0.01 level). Considering each character separately, there are four pattern types. One common type of pattern of geographic variation is illustrated by α - Pinene (character 1) (Fig. 47) and β - Pinene (character 2). The Braendler's scrub population (3) is rich in α - Pinene and is significantly different with respect to this character, from all the other populations. The two Kangaroo Island populations (1 & 2) have the lowest quantities of α - Pinene, whereas the other populations (4 - 6) have intermediate amounts.

The second common type is exemplified by the character 18 ($C_{15}H_{24}$) (Fig. 48). The Kingscote (2) and the Little Desert (4) populations are rich in this sesquiterpene but the other populations (1, 3, 5 & 6) have progressively lower amounts of this component. The monoterpene $C_{10}H_{14}O$ (character 13) has a similar pattern of geographic variation.

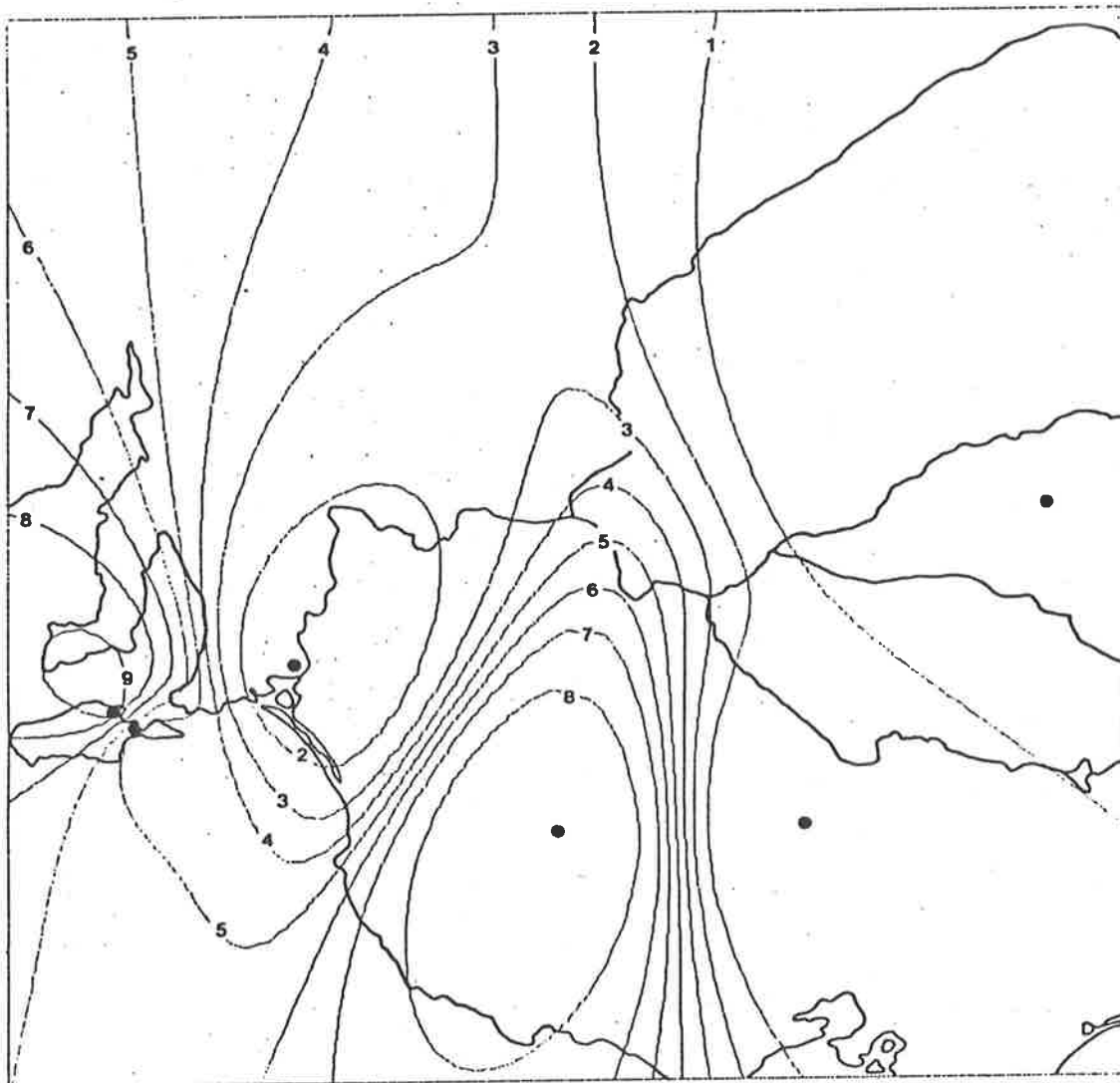
The third common type of pattern is a slight modification of the previous type. This type is illustrated by p - Cymene (character 7) (Fig. 49). The Kangaroo Island populations (1 & 2) are rich in p - Cymene (the Kingscote population richer). The mainland populations tending to show a combined west-east and north-south trend. That is, the Rankin Springs (6) and the Braendler's scrub (3) populations are richer in the relevant component (e.g. p - Cymene, Fig. 46; character 11 - $C_{10}H_{18}$), with the Little Desert (4) and the Bendigo (5) populations having progressively smaller amounts.

The fourth common type of pattern is exemplified by character 15 -



03 05 06 04 02 01

Fig. 47. Contour map (with summary of SNK test) of % composition of α - Pinene (character 1) for populations of *P. aspalathoides*. Contour symbols and values are: 1 = 0.33; 2 = 0.80; 3 = 1.27; 4 = 1.74; 5 = 2.21; 6 = 2.68; 7 = 3.15; 8 = 3.62; 9 = 4.09.



02 04 01 03 05 06

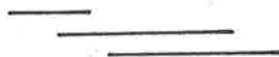
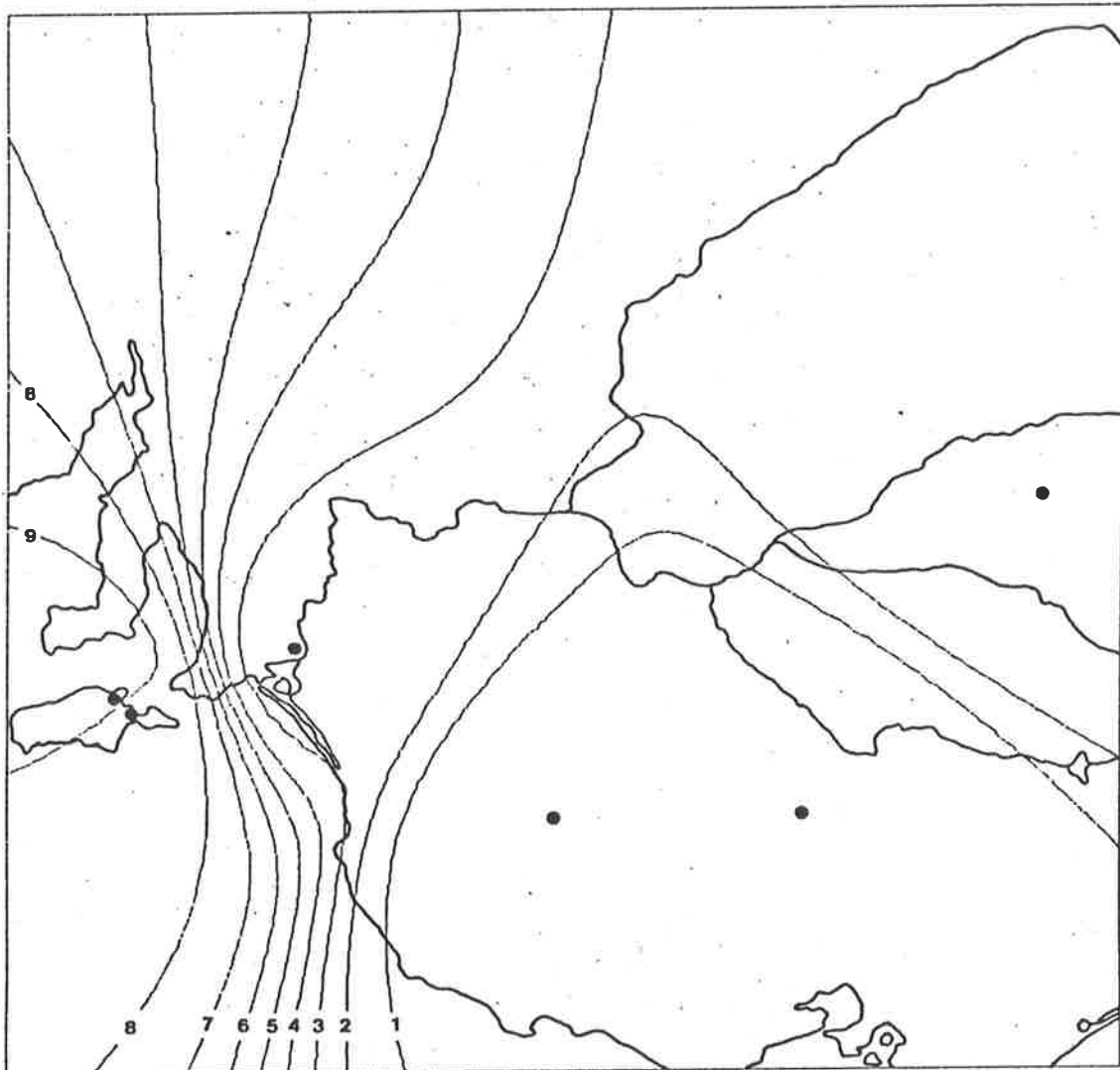


Fig. 48. Contour map (with summary of SNK test) of % composition of $C_{15}H_{24}$ (character 18) for populations of *P. aspalathoides*. Contour symbols and values are: 1 = 0.53; 2 = 0.86; 3 = 1.18; 4 = 1.50; 6 = 2.14; 7 = 2.47; 8 = 2.79; 9 = 3.11.



02 01 04 06 05 03

Fig. 49. Contour map (with summary of the SNK test) of % composition of p - Cymene (character 7) for populations of *P. aspalathoides*. Contour symbols and values are: 1 = 0.16; 2 = 0.28; 3 = 0.39; 4 = 0.51; 5 = 0.63; 6 = 0.75; 7 = 0.86; 8 = 0.98; 9 = 1.10.

$C_{10}H_{16}O$ (Fig. 50) and Maaliol (character 21). The Kangaroo Island populations (1 & 2) are rich in the relevant component, whereas the Braendler's scrub (3) population has significantly low amounts. The other populations (4 - 6) are intermediate between the previous two groups.

The composite differential formed from the 18 characters which showed both a significant F -test and a significant SNK test (both at the 0.01 level) is presented in figure 51. The most rapid changes occur between (i) the Kangaroo Island (1 & 2) and mainland (3 - 6) populations, and (ii) between the Braendler's scrub (3) and the Victorian (4 & 5) populations.

Since the sample is very small for most populations (Table 14), interpretation of these results is difficult and by necessity must be tentative. One consequence of limited population sampling is that it is not known how representative these individuals are of the respective populations. Since chemical forms are usually merely quantitatively different (e.g. Hellyer et al. 1969), a larger sample improves the statistical basis for any consideration of these differences. Obviously the optimal sample size is dependent upon many factors which are possibly different for different taxa. Adams (1970b, 1972a), Hunt & von Rudloff (1974), and von Rudloff (1972a) have found that populations represented by five individuals can still show significant differences between populations. However, five individuals are more likely to represent the minimal sample size. It can be seen, for example, that five individuals probably could not adequately represent the heterogeneity of the Kingscote population (Fig. 44).

It was found that the amount of 1,8 - Cineole was consistently high (mean value of 38.6% of the total composition for all populations) and is

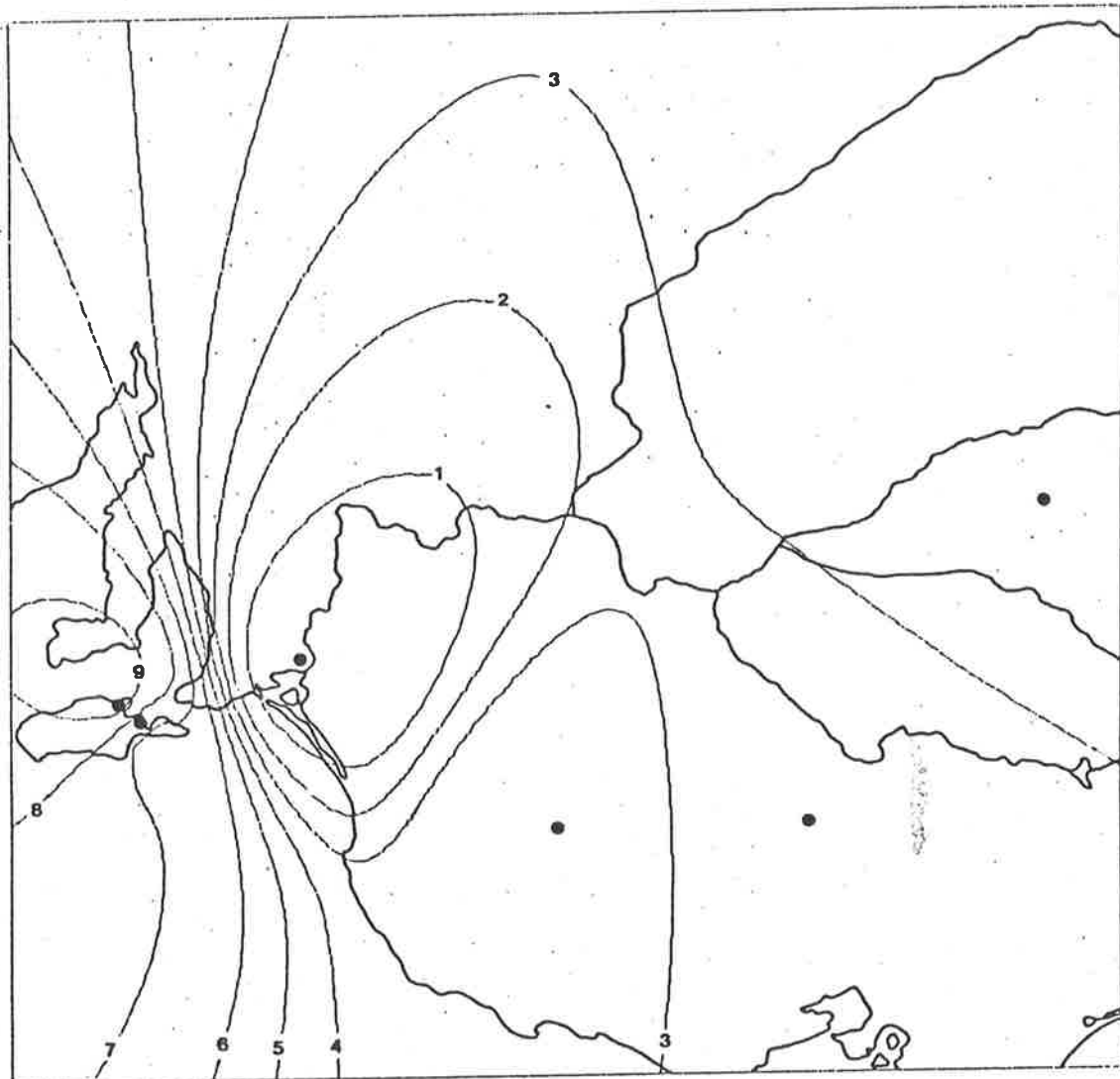


Fig. 50. Contour map (with summary of SNK test) of % composition of $C_{10}H_{16}O$ (character 15) for populations of *P. aspalathoides*. Contour symbols and values are: 1 = 0.03; 2 = 0.09; 3 = 0.15; 4 = 0.21; 5 = 0.27; 6 = 0.33; 7 = 0.39; 8 = 0.45; 9 = 0.51.

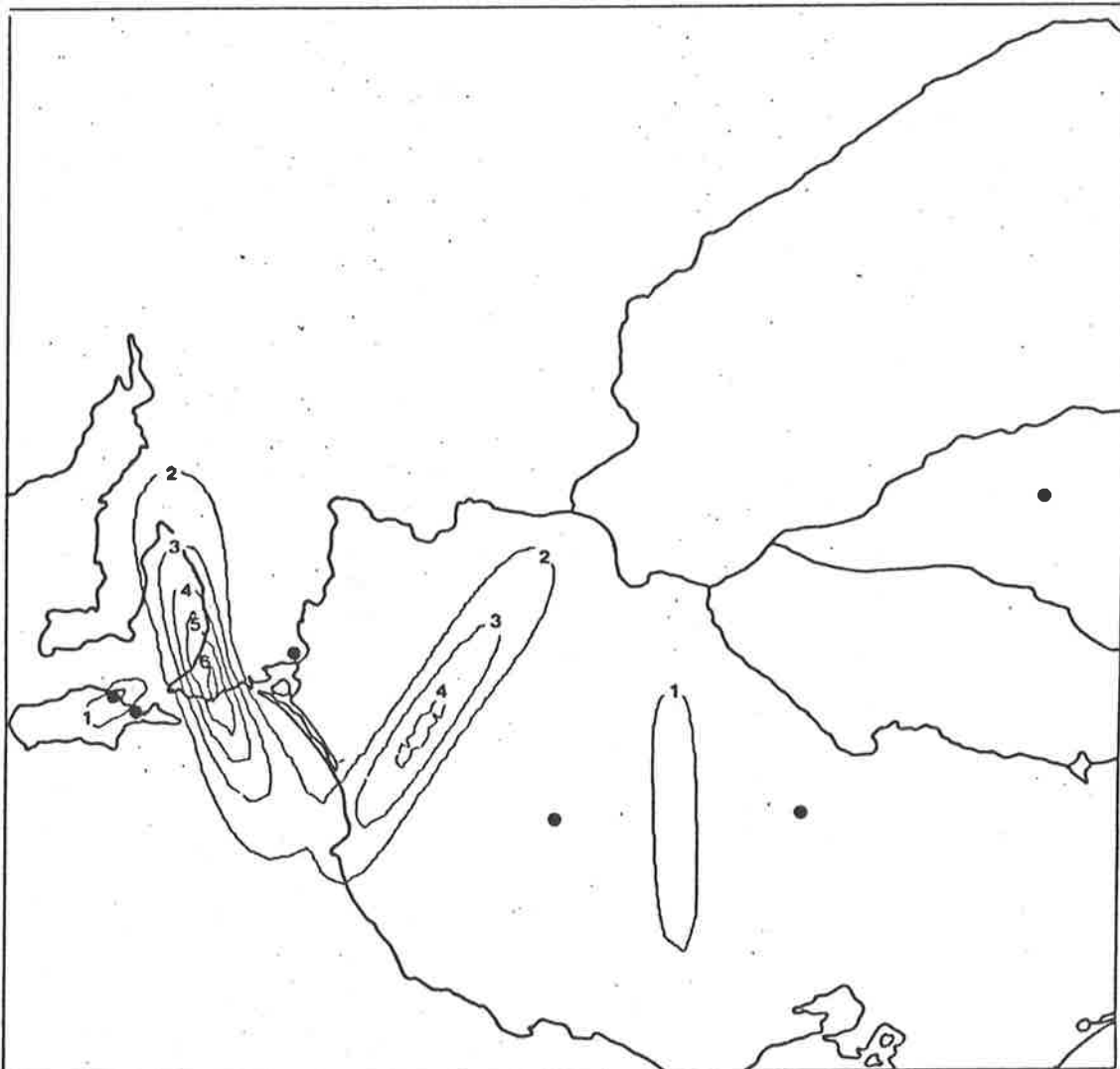


Fig. 51. The composite differential formed from volatile leaf oil compounds in populations of *P. aspalathoides*. Contour symbols and values are: 1 = 0.09; 2 = 0.15; 3 = 0.22; 4 = 0.28; 5 = 0.34; 6 = 0.40.

the major compound of the leaf oils. Lassak, in Althofer (1978) and Lassak (1980) also found that 1, 8 - Cineole was the main component of P. aspalathoides. Similarly, in a preliminary study of P. serpyllifolia (the Mt. Greenly population), I found that it was also the main component (54.4%).

The Kangaroo Island populations (1 & 2) have significantly high values of ρ - Cymene and several other monoterpenes (e.g. characters 9, 13 & 15). These populations are also rich in the two sesquiterpenes, Maaliol and character 18 (Table 13). The presence of Maaliol and ρ - Cymene is of particular interest since the specimens (from New South Wales) processed by Lassak (1980) lacked both of these compounds.

The Braendler's scrub population (3) is characterized by significantly high values of α - and β - Pinene. However, this may be an artifact of inadequate sampling, particularly for α - Pinene, which had values ranging from 2.3 to 5.9%. Since Lassak (1980) recorded a value of 2%, the small sample size in my study may have over-emphasized a chemical form rich in this compound, which is represented by certain individuals of the population.

To assess the extent to which the oil data supports the morphological data in explaining the pattern of geographic variation, the matrices of the Manhattan metric distances of both the leaf oil characters and the morphological characters (based on the same individuals) were compared by computing Pearson's correlation coefficient (r). The correlation coefficient for the comparison of the two matrices, based on all characters (except KHDI and STMX, refer p. 65), was only 0.3. However, a correlation coefficient of $r = 0.61$ resulted from the comparison of the two matrices, based on those characters which had a significant F-test and a significant SNK test (both at the 0.01 level). Since the chemical characters appear to be under

strict genetic control (Hanover 1966a, 1966b; Forsen & von Schantz, in Bendz & Santesson 1973; von Rudloff 1972b; Irving & Adams, in Runeckles & Mabry 1973), the regions of differentiation (Figs. 26 & 51), in particular the region of rapid change between the mainland and the Kangaroo Island populations, may reflect genotypic as well as phenotypic distinctness.

FUNCTION OF VOLATILE OILS IN PROSTANTHERA: A DISCUSSION

The function of terpenoids is very inadequately known and has often been regarded as obscure. For example, Bonner (1950) assigned no function to lower terpenoids, whereas Sandermann (1962) regarded terpenoids as waste products. Contrary to the above, Fraenkel (1959) concluded that the secondary compounds (in a number of families) repelled or attracted insects. A similar view was expressed by Briquet (1895) for the Labiatae. Recent biochemical and physiological studies have shown that many terpenoids participate in the metabolism of the plant (refer Loomis, in Pridham 1967). Other studies have further established probably functions for terpenoids (e.g. Ehrlich & Raven 1965; Goodwin, in Pridham 1967; Harborne 1972 (& papers therein), 1977 (& literature cited therein), 1978 (& papers therein); Langenheim 1969, 1981; Muller 1966; Nicholas 1973; Smith 1976; and Sundheimer & Simeone 1970). However, Nicholas (1973) concluded that 'there is no established role for any monoterpene with regard to its physiological or biochemical function within plant tissues'. Furthermore, because of the large number of terpenoids already known, it is unlikely that every one will have a specific function (Goodwin, in Pridham 1967). Smith (1976) suggests that the terpenoids are more likely to have a collective function.

Volatile oils as a defence against animals and insects

In Prostanthera I have noted that the foliage (particularly of sect.

Klanderia) is not attacked by insects nor is it usually grazed by animals (p. 33). Whether or not the high concentration of volatile oils (in leaves, stems and calyces) is a definite insect-repellant and/or is unpalatable to animals, is not known. Oh et al. (1967) showed that monoterpenes, which are common in Prostanthera (refer Table 13; also Lassak, 1980), inhibit digestion in deer and sheep. It is not clear, however, whether these effects are related to palatability differences (Harborne 1977). Harborne (1977) summarizes the feeding preferences of insects with respect to the known role of various chemicals as insect attractants and/or deterrents. Monoterpenes are frequently olfactory attractants, whereas a number of sesquiterpenes are important repellants. The importance of monoterpenes as feeding repellants is not clear (Harborne, 1977).

Initial analyses of P. monticola and P. walteri (both sect. Klanderia) indicate that both of these species have relatively low quantities of volatile leaf oils. However, the foliage of both species was not grazed and it appeared to be free from insect attack. Therefore, at least the amount of oil does not appear to influence insect or animal feeding preferences.

Sumimoto et al. (1975; as summarized in Harborne 1977) found that the chemical insect repellent of Pinus was present only in very small amounts. Preliminary analysis of the leaves of P. behriana (sect. Prostanthera series Subconcaevae Benth.) show that this species either lacks volatile leaf oils or these oils occur only in trace amounts. Similar to P. monticola and P. walteri, the foliage did not appear to be affected by insects. However, this species is sometimes grazed (presumably by kangaroos and rabbits). A few other species (also of sect. Prostanthera series Subconcaevae Benth.), viz. P. baxteri, P. nivea, P. saxicola, and P. suborbicularis,

appear to lack volatile oils (Lassak 1980). At this stage, the evidence concerning the possible unpalatability (to grazers) and the possible role as insect repellants (for Prostanthera) is inconclusive.

Volatile oils and pollination

Insect pollinated flowers typically have a floral scent (Bergström, in Harborne 1978; Faegri & van der Pijl 1979; Hills et al. 1972; Holman & Heimermann 1973; Thien et al. 1975). However, the flowers of sect. Prostanthera (which are insect pollinated) (p. 26) appear to lack floral odour (at least to human senses). I have noted that a number of species in this section (in particular P. ovalifolia and P. lasianthos) readily volatilize their essential oils, especially when in flower. It seems likely that the essential oils of the leaves, branches and calyces (in particular, the monoterpenes) may act as a general olfactory attractant which guides insects to the scentless flowers. However, until the presence or absence of floral odours in Prostanthera is verified using techniques similar to those of Bergström (in Harborne 1978) or Holman & Heimermann (1973), it is difficult to assess the importance of essential oil volatilization in relation to pollination. Since insects are extremely sensitive to small concentrations of volatile substances, 'flower odours are probably effective at relatively low concentrations' (Harborne 1977).

SYSTEMATIC TREATMENT

The following circumscription of *Prostanthera* section *Prostanthera* is based on the work of Bentham (1870). This brief description is offered so that the diagnostic features of the two sections can be more readily compared (refer Figs 52 & 53).

a. *Prostanthera* section *Prostanthera* - Fig. 52

Benth., Fl. austral. 5(1870)93 [as sect. '*Euprostanthera*']; Briq., in Engl. & Prantl, Nat. Pflanzenfam. 4, 3a(1895)220 [as sect. '*Euprostanthera*']; C. Moore, Handb. fl. New S. Wales (1893)350 [as sect. 'I'].

Calyx tube striate, lobes unequal in length. Corolla tube short, broad distally; abaxial lobe longer and more spreading than the erect adaxial lobes. Fruit with 4 mericarps enclosed by inward folded abaxial calyx lobe; adaxial calyx lobe usually recurved.

Note: This section contains approximately 80 species. Although it is in need of revision, a systematic account is not included in this study.

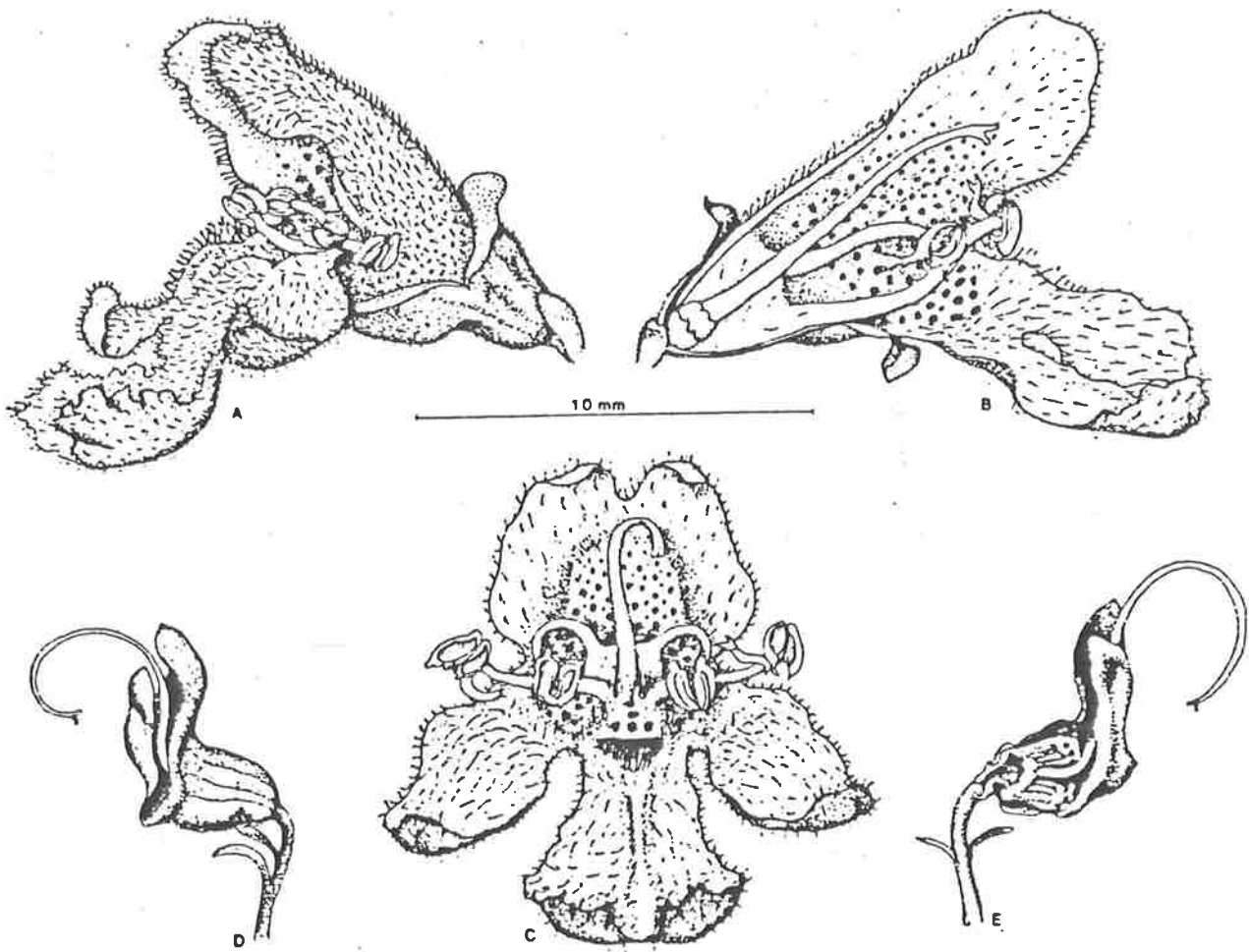


Fig. 52 *Prostanthera lasianthos*. - A. flower; B. open flower with half of calyx and corolla removed; C. distal view of corolla, androecium (after anthesis), style and stigma; D. calyx after fertilization; E. part of calyx removed to show two mericarps and style (all from cultivated material, Burrendong Arboretum).

b. *Prostanthera* Labill. sect. *Klanderia* - Fig. 53

Prostanthera sect. *Klanderia* (F. v. Muell.) Benth., Fl. austral.

5(1870)105; C. Moore, Handb. fl. New S. Wales (1893)352 [as sect. 'II'].

Klanderia F. v. Muell., Linnaea 25(1852)426; Walpers, Ann. bot. syst.

5(1858)667; - Type species: *Prostanthera chlorantha* (F. v. Muell.) Benth.

Prostanthera sect. *Cryphia* (R. Br.) Briq., in Engl. & Prantl, Nat.

Pflanzenfam. 4, 3a(1895)220; *Cryphia* R. Br., Prodr. 1(1810) 508; Poir., in

F. Cuvier (Ed.), Dict. sci. nat. 2nd ed. 12(1819)78; Sprengel, Linn. Syst.

veg. ed. 16, 2(1825)704; Gen. pl. 2(1831)468; Benth., Labiat. gen. spec.

(1834)448; G. Don, Gen. hist. 4(1837-8)798; Endl., Gen. 8(1838)621; D. Dietr.,

Syn. pl. 3(1842)354; Walpers, Rep. bot. syst. 3(1844)764; *ibid* 3(1845)985;

Benth., in DC., Prodr. 12(1848)558 - Based on: - *P. serpyllifolia*

(R. Br.) Briq. and *C. microphylla* R. Br.

Small shrubs, up to c. 2 m high, diameter up to 1(-1.5) m. Leaves with margin + entire; venation usually not visible, sometimes faint.

Inflorescence racemiform on leafy branches, uniflorescence monadic; prophylls

2. Calyx with 2 more or less equal lobes, margin entire. Corolla glabrous

basally on outer surface, at least on that part enclosed by the calyx; tube

long, + straight to incurved, gradually expanded distally, mouth + elliptic

in outline, 4 - 8 mm wide along shortest axis, inner surface glabrous;

median adaxial and abaxial lobes usually + equal in length, usually ovate to

obovate, apices often rounded, abaxial lobe slightly recurved to reflexed,

adaxial lobe extended forward, sometimes recurved to reflexed near apex,

concave in section; lateral lobes usually shorter than median lobes, +

triangular, spreading to reflexed, apices usually subacute to obtuse.

Stamens 4; filaments ligulate to subterete, glabrous; anthers basifixed between lobes, 1 - 2.5 mm long, introrse, connective with small fringe at distal end of filament. Disc up to 1 mm long, diameter up to 1.5 mm.

Pistil glabrous; ovary + cylindrical-ovoid to obovoid, 4-lobed, lobes 0.1 - 0.3 mm long, enlarging after fertilization; style terminal, slender, ligulate to terete; slightly curved, lying next to inner adaxial surface of corolla; stigma shortly bifid. Fruit of 4 mericarps, mericarps not enclosed by calyx lobes; seed + flattened, ellipsoid to oblong-ellipsoid, rarely sub-cylindrical, slightly incurved, 1 - 2.5 x 0.5 - 0.8 x 0.2 - 0.5 mm, thickened distally.

Recognized taxa and their distribution: In this revision fourteen species are recognized in section Klanderia (viz. P. aspalathoides, P. calycina, P. chlorantha, P. florifera, P. grylloana, P. incurvata, P. laricoides, P. monticola, P. patens, P. pedicellata, P. ringens, P. semiteres, P. serpyllifolia and P. walteri). Prostanthera sect. Klanderia occurs in all mainland States of Australia (except the Northern Territory), but is absent from Tasmania (Fig. 53-II). The number of species of sect. Klanderia which occur in each State are: Queensland 2; New South Wales 4; Victoria 4; South Australia 5; and Western Australia 7. P. serpyllifolia ssp. serpyllifolia is confined to South Australia, whereas P. serpyllifolia ssp. microphylla occurs in New South Wales, Victoria, South Australia and Western Australia. The two subspecies of P. semiteres (viz. ssp. semiteres and ssp. intricata) are confined to Western Australia. P. grylloana, P. incurvata, P. laricoides, P. patens and P. pedicellata are confined to Western Australia. P. calycina, P. chlorantha and P. florifera are confined to South Australia. P. aspalathoides occurs in all eastern mainland states plus South Australia. P. monticola occurs in New South Wales and Victoria. P. ringens occurs in Queensland and New South Wales. P. walteri is restricted to south-eastern Victoria.

Fig. 53. Floral structure and species diversity of *Prostanthera* sect. *Klanderia*. I. *Prostanthera aspalathoides*. - A. flower; B. open flower with half of calyx and corolla removed; C. distal view of corolla, androecium, style and stigma, as seen from abaxial side; D. calyx after fertilization; E. part of calyx removed to show two mericarps and style (all Conn 3307). II. Species diversity of *Prostanthera* sect. *Klanderia*. - above the hyphen the endemic species for each State, below the hyphen the non-endemic species.

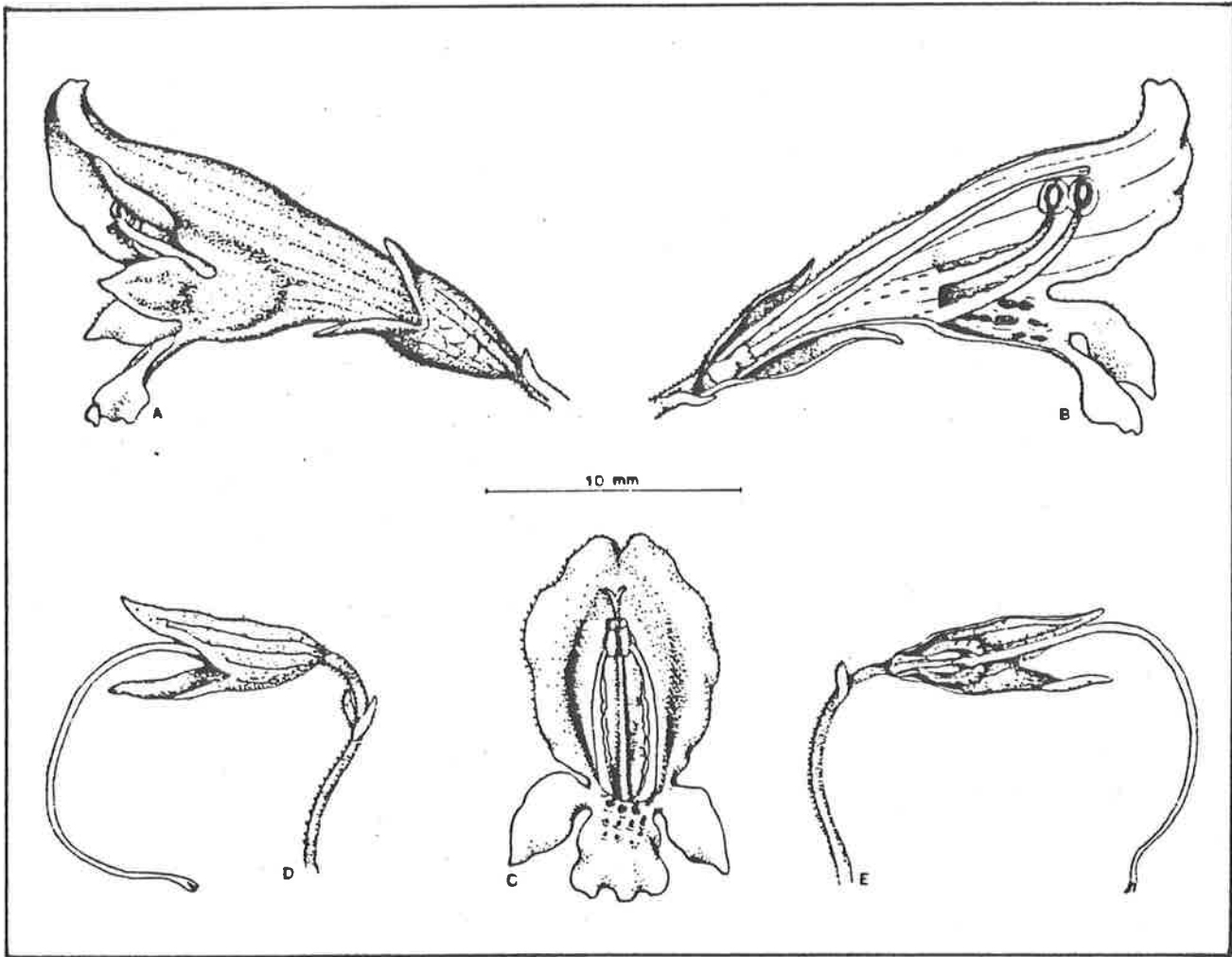


Fig. 53 - I

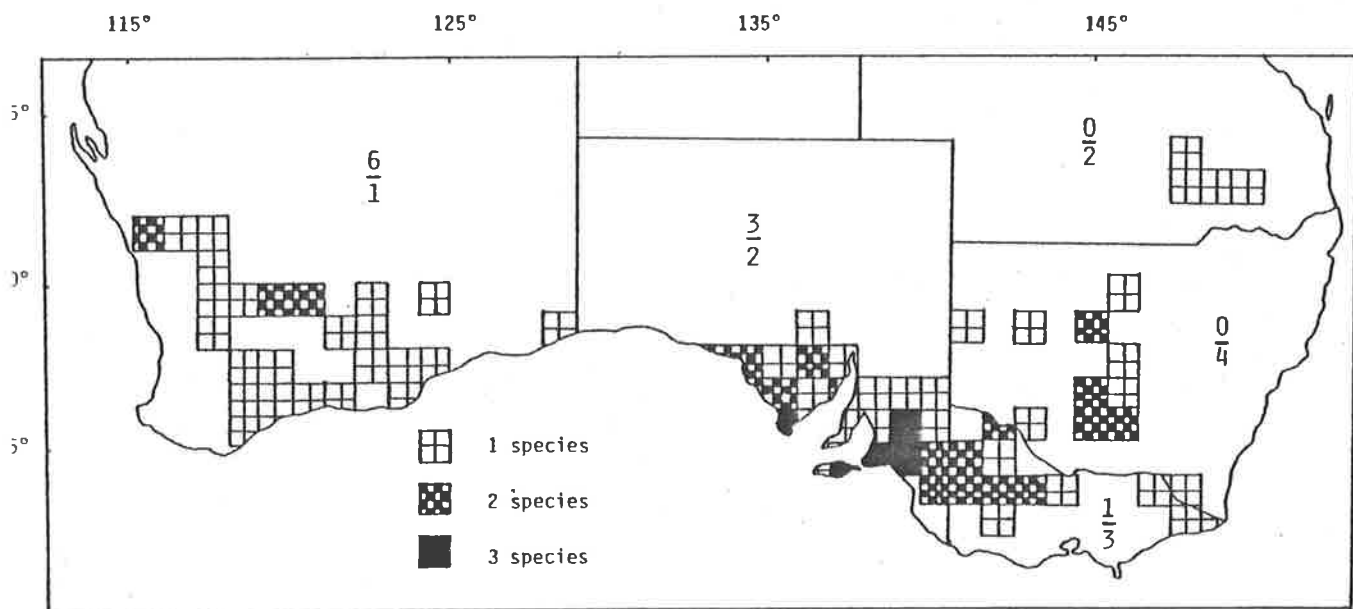


Fig. 53 - II

KEY TO SPECIES

- 1a. Inner surface of calyx hairy, may be sparsely so,
or if glabrous then pedicel at least 9 mm long with
branches glabrous and densely glandular, and corolla
red 2
- 1b. Inner surface of calyx glabrous, sometimes with a
few hairs near margin 8
- 2a. Leaves 5-13 mm wide; lamina 15-50 mm long;
corolla 30-35 mm long; prophylls 10-18 mm long
(New South Wales, Victoria) 13. *P. monticola*
- 2b. Leaves up to 2.5(-3) mm wide; lamina up to
20 mm long; corolla 12-27 mm long; prophylls
2(-2.5) mm long (Western Australia) 3
- 3a. Outer surface of calyx hairy throughout
(sometimes sparsely so) 4
- 3b. Outer surface of calyx glabrous or if hairy,
then hairs restricted to distal part of
calyx and then sparsely so 7
- 4a. Anther appendage absent; inner surface of calyx
sparsely hairy; branches glabrous; pedicel*
7-13 mm long 7. *P. pedicellata*
- 4b. Anther appendage present; inner surface of calyx
densely hairy; branches hairy (usually densely
so); pedicel less than 3.5 mm long 5
- 5a. Leaves spatulate, conduplicate 12. *P. grylloana*
- 5b. Leaves ± terete or ovate to oval; margin recurved
so lamina often appearing oblong, never conduplicate 6

* Pedicel = a₁ axis + anthopodium.

- 6a. Leaves less than 2 mm long; lamina length to width ratio less than 2; calyx lobes length to tube ratio greater than 0.5 3. *P. patens*
- 6b. Leaves at least 10 mm long; lamina length to width ratio (6-)12-32; calyx lobes length to tube ratio less than 0.45 10. *P. laricoides*
- 7a. Branches hairy, sometimes restricted to two opposite lines along branches (rarely glabrous); pedicel up to 1.5(-2) mm long; leaves usually incurved 8. *P. incurvata*
- 7b. Branches glabrous (rarely with an occasional hair); pedicel 3-15 mm long; leaves \pm straight to slightly recurved 9. *P. semiteres*
- 8a. Prophylls inserted at base or on lower half of pedicel; [anthopodium to a_1 axis ratio (1-)2-7] (Queensland, New South Wales) 11. *P. ringens*
- 8b. Prophylls inserted at base of calyx or on upper half of pedicel; [anthopodium to a_1 axis ratio usually less than 1] 9
- 9a. Hairs irregularly ramose, \pm densely covering branches, leaves, pedicels and calyx (simple hairs may also be present) (South Australia) 1. *P. chlorantha*
- 9b. Hairs simple, sometimes with a few ramose hairs on calyx (Kangaroo Island populations of *P. serpyllifolia* ssp. *microphylla*), never on branches or leaves 10

- 10a. Hairs (of branches, leaves - particularly on margin and midrib of abaxial surface and calyx) stiff, straight, appressed; hair apex directed towards distal part of organ (Eyre Peninsula, South Australia) 4. *P. calycina*
- 10b. Hairs (of branches, leaves and calyx) + soft, recurved to reflexed, never appressed, frequently curled (widespread) 11
- 11a. Leaves + terete to linear-oblongate 12
- 11b. Leaves ovate to lanceolate, sometimes suborbicular, never terete or linear-oblongate 13
- 12a. Anther appendage 1-2.5 mm long; calyx 7-12 mm long (Gawler Ranges, South Australia) ... 6. *P. florifera*
- 12b. Anther appendage up to 0.3(-0.5) mm long; calyx 5-7 mm long (widespread, absent from Gawler Ranges) 5. *P. aspalathoides*
- 13a. Lamina (10-)18-26(-38) x 5-15(-17) mm; petiole 2-5(-8) mm long; venation faint; abaxial median corolla lobe 5-10 mm long; lateral corolla lobes (4-)5-7(-10) mm long (eastern Victoria) 14. *P. walteri*
- 13b. Lamina (1-)1.5-13 x 0.5-4(-6) mm; petiole absent or 0.4-2.5(-5) mm long; venation not visible; abaxial median corolla lobe 3-4 mm long; lateral corolla lobes 1-4.5 mm long (widespread; in Victoria N & W of Great Dividing Range) 2. *P. serpyllifolia*

1. *Prostanthera chlorantha* (F.v. Muell.) F.v. Muell. ex Benth. -

Figs 54 & 55

Prostanthera chlorantha (F.v. Muell.) F.v. Muell. ex Benth., Fl.

austral. 5(1870)108; F.v. Muell., Fragm. 9(1875)162; *op. cit.* 10(1876)18;

Woolfs, Pl. New S. Wales (1885)83; F.v. Muell., Key Vict. pl. 2(1885)42;

op. cit. 1(1887)386; Tate, Trans. Roy. Soc. S. Austral. 12(1889)111;

Handb. fl. extratrop. S. Austral. (1890)151, 252; C. Moore, Handb. fl.

New S. Wales (1893)353; Briq., in Engl. & Prantl, Nat. Pflanzenfam. 4,

3a(1895)220; Dixon, Pl. New S. Wales (1906)232; Guilfoyle, Austral. pl.

(1911)302; J.M. Black, Fl. S. Austral. ed. 1, 3(1926)492; *op. cit.* ed. 2,

4(1957)739, t. 1058; Hj. Eichler, Suppl. Black's fl. S. Austral. (1965)269;

Galbraith, Wildfl. SE. Austral. (1977)326; Althofer, Cradle of Incense (1978)

124, 128, 129. *Klanderia chlorantha* F.v. Muell., Linnaea 25(1852)426;

Walpers, Ann. bot. syst. 5(1858)667. - L e c t o t y p e (here chosen):

Fischer s.n., -?xi.1851, 'Prostanthera coccinea ferd. Mueller var. chlorantha.

Mount Barker Creek.', South Australia (MEL 41908 - lower left specimen;

isolecto. MEL 41908 - upper and centre right specimens, probable isolecto.

K, MEL 41906, MEL 41907). [refer Typification]

Small shrub, up to 0.5(-1) m high. Branches ± terete, hairy, hairs
ramose, with occasional simple hairs, 0.1 - 0.4 mm long; sparsely glandular.

Leaves mostly arranged along short side branches, hairy, hairs ramose;

petiole absent or if present, then less than 0.5 mm long; lamina suborb-

cular to broad-ovate, 1 - 3 x 1 - 2.5(-3) mm, base rounded, margin entire,

strongly recurved especially towards base and so lamina appearing deltoid,

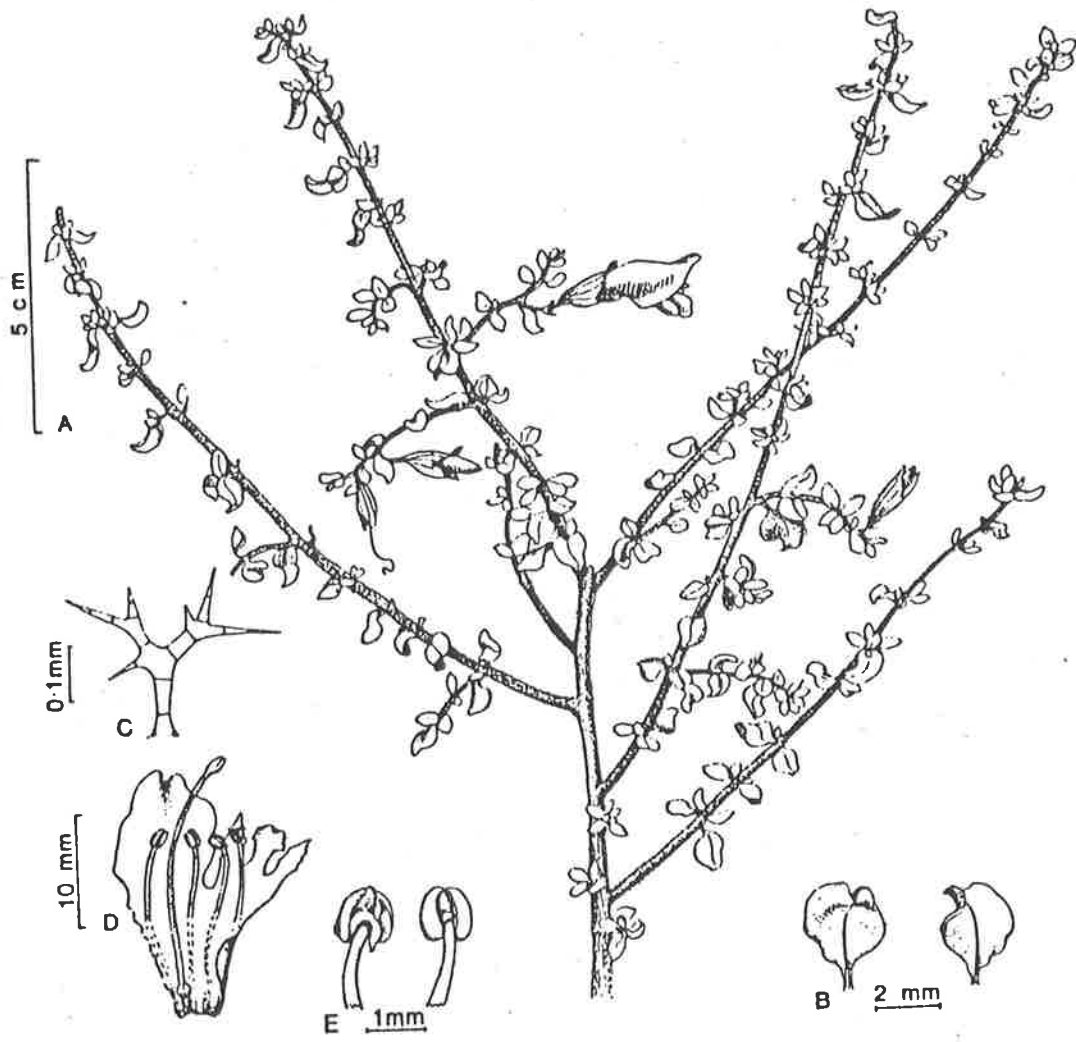
apex obtuse to rounded; venation not visible to indistinct. Pedicel

5 - 13 mm long, slender, often glabrous basally, glabrescent for much of

its length, distally with ramose hairs, sparsely glandular; prophylls

inserted 0.5 - 3 mm from distal end of pedicel and so, usually not or occasionally just, overlapping basal part of calyx (sometimes alternately arranged), + linear-oblongate, 1 - 2 x c. 0.5 mm long, slightly concave, abaxial surface and margin hairy (hairs ramose) and lepidote, adaxial surface glabrous, apex obtuse. Calyx 8 - 12 mm long, green, often with red-purple ribs (streaks), especially on tube; outer surface ramosely tomentose and lepidote; inner surface glabrous; tube 5 - 6 mm long; lobes triangular, 3 - 6 mm long, 2 - 4 mm wide at base, apex acute. Corolla 15 - 25 mm long, mauve, blue-green, dusty green-red to green-yellow with a pink tinge; outer surface sparsely hairy distally, hair simple, c. 0.1 mm long; inner surface lacking dark spots, glabrous; tube 10 - 25 mm long; abaxial median lobe obovate, 2 - 5 mm long, c. 2 mm wide at base, slightly recurved, margin + entire to slightly irregular, apex obtuse to rounded, often emarginate, sinus up to 0.2 mm long; lateral lobes oblong-ovate, 4 - 5 mm long, c. 2 mm wide at base, margin entire, apex subacute; adaxial median lobe-pair suborbicular to broad-ovate, 5 - 10 mm long, c. 10 mm wide at base, slightly recurved distally, margin entire, apex rounded, sometimes emarginate, sinus up to 0.5 mm long. Stamens inserted c. 10 mm above base of corolla; filaments c. 5 mm long, with minute broad-triangular glandular trichomes; anthers 1.5 - 2 mm long, base of lobes minutely acuminate, acumen c. 0.1 mm long, apex obtuse to minutely acuminate, although appendage appearing absent, one side of connective usually slightly extended to form a minute basal appendage, appendage up to 0.03 mm long, sometimes with minute broad-triangular trichomes on appendage. Pistil 17 - 22 mm long; 0.5 mm long; ovary c. 0.5 mm long, diameter c. 1 mm at base, lobes small, c. 0.1 mm long; style 15 - 18 mm long, stigma lobes up to 1 mm long. Mericarps 2 - 3 mm long, c. 1 mm wide distally, distally 0.4 - 0.6 mm extended beyond base of style.

Fig. 54. *Prostanthera chlorantha*. - A. twig and flowers;
B. detail of leaves; C. irregularly branched hair; D.
open corolla; E. stamens - ventral and dorsal views (all
Conn 811).



Typification: The herbarium sheet MEL 41908 contains five specimens and two envelopes of fragments. The herbarium label (in Mueller's hand) corresponds with the locality details given in the protologue ('In montibus altis petraeis juxta amnem Mount - Barker - creek sitis flumen Bremer versus Fischer'; Mueller 1852, p. 426). There is close agreement between the brief description provided in the protologue and the lower left specimen of MEL 41908. Since Bentham examined this sheet (initials on label and on one envelope of fragments) this provides additional support for selecting a specimen from this sheet.

Distribution: South Australia - Murray Mallee, Mt Lofty Block (incl. Kangaroo Island), Southern Highlands and Plains [Eyre Peninsula].

Ecology: This species forms small populations of a few scattered plants, on sandy and loamy soils. It is commonly associated with *Banksia*, *Daviesia*, *Comosperma*, and *Leptospermum* shrubland.

Notes: This species is readily identified by the presence of irregularly branched hairs. *P. serpyllifolia* ssp. *microphylla* (from Kangaroo Island) is the only other taxon which has similar indumentum. However, the latter taxon has fewer branched hairs than those of *P. chlorantha*. Furthermore, in ssp. *microphylla* the branched hairs only occur on the calyx. Other features including habit and leaf shape, suggest close affinities between these two taxa.

This species appears to be conservationally endangered.

Selected specimens examined: (c. 60 collections)

SOUTH AUSTRALIA.- Murray Mallee (Goolwa): Hunt 2649, 16.vii.1966, near Currency Creek, on main Goolwa to Strathalbyn road (AD). Mt Lofty Block: Peninsula Uplands (Barossa): Purdie 83, 4.ix.1966, back of Barossa Reservoir (AD); (Para): Ising s.n., -.x.1920, Para River near Gawler (AD); (Hahndorf): Cleland s.n., 18.ix.1965, back road from Harrogate to Monarto (AD); (Sander-grove): Ising s.n., -.vi.1925, Kinchina (AD); (Scotts Hill): Mueller s.n., s. *dat.* Mt Barker Creek (MEL 41903 - 41905); (Inman Valley): Carrick 2959 - 2964, 21.x.1971, Victor Harbour (AD); Kangaroo Island (Mt Marsden): Rogers s.n., -.ix.1908, Retta's Lagoon (NSW); (Cygnet): Eichler 15262, 6.xi.1958, c. 13 km S of Kingscote (AD); (Amberley): P. Wilson 889, 13.xi.1958, near Birchmore Lagoon (AD); (MacGillivray): Carrick 3509, 9.xi.1973, Kingscote Council Sand Reserve, near MacGillivray (AD).-[Eyre Peninsula] Southern Highlands and Plains (Lincoln): Dixon s.n. in herb. Tate, -.x.1883, Port Lincoln (AD 96928849).



Fig. 55. Distribution map of *Prostanthera chlorantha*.

2. *Prostanthera serpyllifolia* (R. Br.) Briq. - Figs 56-58

Cryphia serpyllifolia R. Br., Prodr. (1810) 508. - *Prostanthera serpyllifolia* (R. Br.) Briq., in Engl. & Prantl, Nat. Pflanzenfam. 4, 3a (1895) 220. — T y p e: R. Brown s.n. [J.J. Bennett 2360], anno 1802-5 [22.ii.1802 (R. Br. MSS. - microfilm copy at AD)], South Coast, Bay IX (also refer R. Br. MSS.) [Memory Cove (Stearn 1960)], southern Eyre Peninsula, South Australia (BM *n.v.*; probable duplicates in BRI, E, K, MEL 43408 - left specimen, P, S). [for full synonymy and notes on typification, see *ssp. serpyllifolia*]

C. microphylla R. Br. *lc.* [see *ssp. microphylla*]

P. microphylla Benth., Labiat. gen. spec. (1834) 454: [see *ssp. microphylla*]

P. coccinea F.v. Muell., Trans. Phil. Soc. Victoria 1 (1855) 48. [see *ssp. serpyllifolia*, *ssp. microphylla*]

P. arenicola S. Moore, J. Bot. 59 (1921) 247. [see *ssp. microphylla*]

P. microphylla f. *aeruginosa* J.H. Willis, Vict. Natural. 73 (1957) 200. [see *ssp. microphylla*]

Small shrub, prostrate to erect, up to 0.5(-1.6) m high. Branches + terete, often slightly flattened distally, moderately to densely hairy, hairs (0.09-)0.1 - 0.4(-0.5) mm long, white; glandular, glands hemispherical, 1 - 35(-90) glands/mm², rarely eglandular. Leaves sparsely to densely hairy, occasionally glabrous, sparsely to densely glandular, glands sunken in pits or raised and hemispherical; petiole absent or if present, then up to 1.5(-3) mm long; lamina oval (rarely suborbicular) to oblong-ovate, (1-)1.5 - 13 x (0.5-)0.7 - 4(-6) mm, [length to width ratio (1-)1.3 - 4(-5.5), length of maximum width from base to total lamina length (0.07-) 0.2 - 0.6(-0.7)]; base subattenuate to rounded; margin entire, recurved;

apex obtuse to rounded; venation indistinct, base of midrib sometimes slightly raised on abaxial surface, sometimes slightly sunken on adaxial surface. Pedicel (0.8-)1 - 5(-13) mm long, \pm terete, green or maroon, glabrous or hairy, hairs (when present) 0.09 - 0.4(-0.5) mm long, white; prophylls inserted at base of calyx (rarely up to 1 mm from base of calyx), hence overlapping base of calyx, narrow-oblong to \pm oblong, (1.1-)2 - 4(-5.3) x (0.3-)0.5 - 0.8(-1) mm [length to width ratio (2.5-)3 - 7.5(-12)], slightly concave, often recurved distally, rarely reflexed, glabrous or sparsely to densely hairy, hairs often restricted to margin, margin entire, usually slightly recurved, apex obtuse. Calyx (4.3-)5 - 12 mm long, maroon or green; outer surface glabrous, or with a few scattered hairs to densely hairy, hairs white, sparsely to densely glandular, glands hemispherical, inner surface glabrous; tube 3 - 6(-7) mm long; lobes \pm broad-deltoid, 1.5 - 4.5(-5) mm long, 4 - 6 mm wide at base, margin entire, apex \pm obtuse to rounded. Corolla 15 - 22 mm long, pink to mid-red, mid (metallic) blue-green, occasionally yellow, inner surface paler than outer surface, outer surface glabrous at base, sparsely to densely hairy distally, inner surface glabrous; tube 9 - 17 mm long; abaxial median lobe \pm oblong-deltoid to \pm obovate, 3 - 4 mm long, \pm recurved to reflexed, margin entire, apex obtuse to broadly rounded (when obovate) often emarginate, sinus up to 0.8 mm long; lateral lobes \pm ovate to deltoid, often narrowly so, sometimes obovate, 1 - 4.5 mm long, \pm recurved to reflexed, margin entire, sometimes irregular distally, apex obtuse to subacute; adaxial median lobe-pair broadly deltoid, 5 - 6.5 mm long, slightly incurved basally, often recurved distally, margin entire, apex obtuse, often slightly emarginate, sinus up to 0.3(-0.5) mm long. Stamens inserted c. 8.5 - 9 mm from base of corolla; filaments c. 5.5 - 9 mm long, with a few glandular trichomes; anthers 1 - 2 mm long, base of lobes with a minute acumen, acumen

up to 0.1 mm long, connective basally extended to form 1 or 2 short appendages, appendages (0.1-)0.4 - 1.4 mm long, appendage rarely absent.

Pistil 20 - 24 mm long; ovary 0.5 - 0.8 mm long, diameter at base 0.6 - 1 mm, lobes small, c. 0.1 mm long; style 19 - 23 mm long; stigma lobes up to 0.5 mm long. Mericarps 1.5 - 1.7 mm long, distally 0.5 mm extended beyond base of styles.

Distribution: Toowoomba, Queensland (Bailey, 1901); New South Wales - Central Western Slopes, South Western Plains; Victoria - western Northern Plains, Mallee; South Australia - Murray Mallee, Mt Lofty Block (incl. Kangaroo Island), Yorke and Eyre Peninsulas; and Western Australia - south-eastern Eremaean, and South West.

Ecology: This species frequently occurs in Mallee communities, particularly on loamy and sandy soils which are overlying and associated with calcarenite (limestone), frequently with outcrops of calcrete.

KEY TO SUBSPECIES OF *PROSTANTHERA SERPYLLIFOLIA*

- 1a. Lamina 4 - 13 x 1 - 4(-6) mm, + flat (straight), usually not recurved or reflexed, leaves not clustered; petiole 0.4 - 1.5 (-3) mm long; pedicel 3 - 15 mm long; calyx (6-)8 - 12 mm long
 2.1 ssp. *serpyllifolia*
- 1b. Lamina (1-)1.5 - 3(-3.5) x 0.5 - 1(-1.5) mm, recurved to reflexed and/or majority of foliage occurring on short lateral axes so that leaves appearing clustered; petiole absent or up to 0.3(-0.5) mm long; pedicel 0.7 - 2.5(-5) mm long; calyx (4.3-)5 - 7.5(-9.5) mm long..... 2.2 ssp. *microphylla*

2.1 ssp. *serpyllifolia* - Fig. 56

Cryphia serpyllifolia R. Br., Prodr. (1810)508; Sprengel, Linn. Syst. veg. ed. 16, 2(1825)704 ; G. Don, Gen. hist. 4(1837)798; Walpers, Rep. bot. syst. 3(1844)764; Benth., Labiat. gen. spec. (1834)448; in DC., Prodr. 12(1848)588. - *P. serpyllifolia* (R. Br.) Briq., in Engl. & Prantl, Nat. Pflanzenfam. 4, 3a(1895)220; J. M. Black, Fl. S. Austral. ed. 1, 3(1926)492; *op. cit.*, ed. 2, 4(1957)739; Galbraith, Wildfl. SE Austral. (1977)325; Althofer, Cradle of Incense (1978)146, 153. - T y p e: R. Brown [J. J. Bennett 2360], anno 1802-5 [22.ii.1802 (R. Br. MSS. - microfilm copy at AD)], South Coast, Bay IX (also refer R. Br. MSS.) [Memory Cove (Stearn, 1960)], southern Eyre Peninsula, South Australia (BM *n.v.*; probable duplicates in BRI, E, K, MEL 43408 - left specimen, P, S). [Refer typification and p. 9]

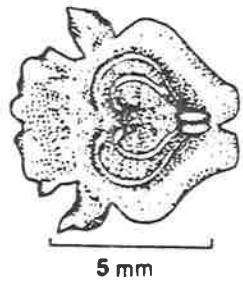
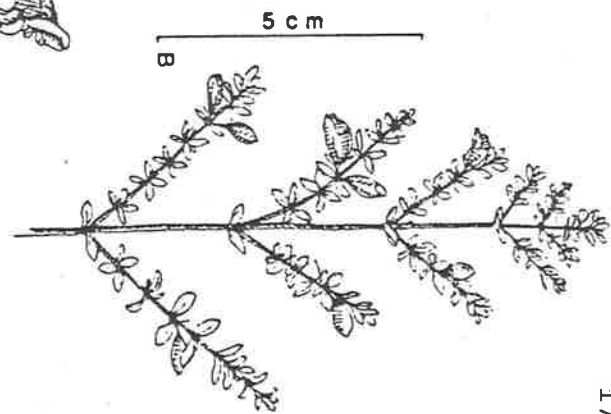
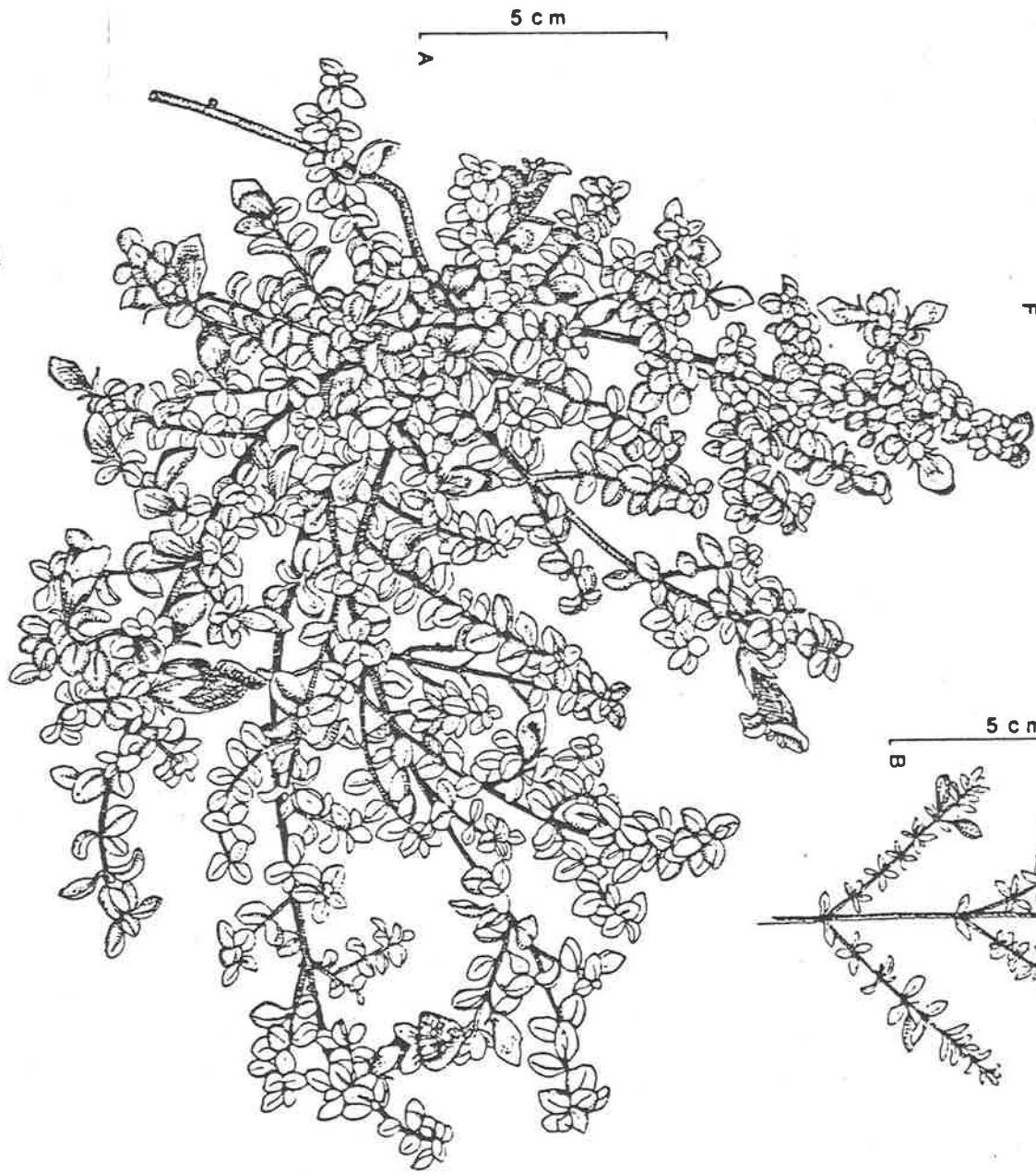
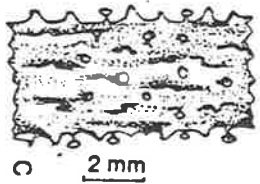
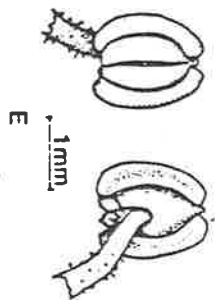
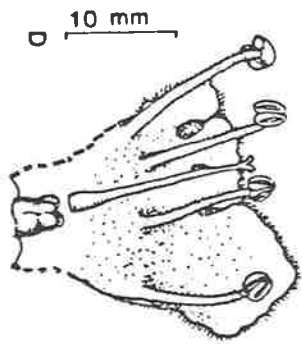
P. coccinea F. v. Muell., [Sec. gen. report veg. colony (Oct. 1854) 13, *nom. nud.*] Trans. Phil. Soc. Victoria 1(1855)48, p.p.; J. Bot. 8(1856) 168, p.p.; Fragm. 6(1868)108, p.p.; *op. cit.* 9(1875)162, p.p. -
 L e c t o t y p e (here chosen): Anon. s.n., s. dat., 'Prope m. Dutton. Fruticul. humil. diffus.', southern Eyre Peninsula, South Australia (MEL 43386). [refer Typification]

Branches moderately to densely hairy, 26 - 200(-272) hairs/mm², hairs (0.1-)0.15 - 0.4(-0.5) mm long, recurved to reflexed. Leaves arranged along the axis and branches, not clustered along short axes, sparsely to moderately hairy, often glabrous, hairs similar to those of branches; petiole 0.3 - 1.5(-2) mm long; lamina oval to ovate-oblong, 4 - 13 x 1 - 4(-6) mm [length to width ratio (1.5-)2 - 3.5(-4), distance of maximum width from base to total lamina length (0.14-)0.2 - 0.4(-0.6)], base obtuse to sub-attenuate, hairs similar to those of branches, + confined to upper surface, up to 30(-80) hairs/mm². Pedicel (1.5-)2.5 - 5(-13) mm long, usually sparsely hairy or glabrous, hairs similar to those of branches. Calyx (6-)8 - 12 mm long, usually maroon, sometimes green; outer surface glabrous or sparsely to moderately hairy, up to 15(-22) hairs/mm², hairs similar to those of branches, sparsely to densely glandular on outer surface; tube 4 - 6(-7) mm long; lobes 3 - 4.5(-5) mm long, 5 - 6 mm wide at base. Corolla red, often with yellow tinge distally, or metallic blue-green, occasionally yellow; tube 12 - 17 mm long.

Typification: Brown (1810) does not cite any specimens for *Cryphia serpyllifolia* in the protologue. The locality is imprecisely cited as '(M)' [Ora Meridionalis - the South coast from Cape Leeuwin, Western Australia, to the islands of Bass Strait and Wilson's Promontory, Victoria (Stearn 1960)].

Fig. 56. *Prostanthera serpyllifolia* ssp. *serpyllifolia*.

A. twig and flowers (Jackson 2641); B. twig and flowers (Tindale 589); C. glandular trichomes of branch; D. open corolla; E. stamens - ventral and dorsal views (Jackson 2641); F. distal view of corolla and androecium, gynoecium removed (Carrick 3911A).



As pointed out by Burbidge (1956), such imprecise localities are useless for the determination of type localities. However, in Brown's MSS (microfilm copy held at AD, also refer Burbidge 1955), he cites the locality as 'Bay IX' [Memory Cove (Burbidge 1956; Stearn 1960)] and the date of collection as 'Feby. 22. 1802'.

Stearn (1960) gives a detailed account of the Brown herbarium. He suggests that it is best to select as the 'lectotype of a Brownian species the most complete individual specimen in the British Museum annotated by Brown ...'. Therefore, I have delayed the choosing of a lectotype until I have examined Brown's material in the British Museum (see p. 9). J. Carrick (*in adnot.*) mentions a number of specimens held at BM (which I have not examined) which could be referable to the type. Of these, 'Brown 2360. *Cryphia serpyllifolia*, Bay IX South Coast' seems likely to be part of the original collection.

F. v. Mueller applied a broad concept to his 'consolidated' species, *P. coccinea*. His 'consolidated' species concept applied when he reduced a number of taxa to one species. Rather than use one of the existing names, he believed that the person who affected the reductions should 'choose a collective designation for the consolidated species' (von Mueller 1882, pp. vii. & viii). At various stages he included *P. aspalathoides*, *P. serpyllifolia*, *P. microphylla* and *P. caleyi* (Mueller 1855, 1868 & 1875). However, the majority of the annotated herbarium specimens are *P. serpyllifolia*. Contrary to this, most other authors appear to have applied a concept which is much closer to that of *P. microphylla*.

Of the material that I have examined, *Anon. s.n., s. dat.*, 'Prope m. Dutton. Fruticul. humil. diffus.' (MEL 43386) most completely fits the protologue. It is not known if Mueller would have regarded Mount Dutton as 'Spencer's Gulf' (as stated in the protologue). However, it is possible that he may have because he did not visit Eyre Peninsula (Churchill, *et al.* 1978) and so, may not have been aware of the exact locality of Mount Dutton. The brief description on the label (refer above) corresponds with the protologue, where Mueller describes this taxon as 'A low diffuse bush'. The only other specimen which is almost certainly a syntype of *P. coccinea* is *Anon. s.n., s. dat.*, 'Near Spencers Gulf' (MEL 43876).

Distribution: South Australia - [Yorke Peninsula] Southern Yorke Peninsula (Innes); - Western Pastoral: ?Gawler Ranges (*Sullivan s.n.*, MEL 43875); - [Eyre Peninsula] Central Mallee & Dunes (Kyancutta, Cleve, Hambidge, Tooligie, Blue Range, Hincks), West Coast (Drummond, Polda, Mt Cooper, Inkster, Streaky Bay), Southern Highlands & Plains (Marble Range, Yalunda, Peake Bay, Lincoln).

Ecology: Occurs on calcarenite ridges and in sandy to sandy loams of undulating calcreted plains in Mallee communities. At Innes National Park (Yorke Peninsula) it occurs on the limestone cliffs in shallow skeletal calcareous sands, whereas at Mount Greenly (Eyre Peninsula) it is associated with coastal shrubbery in loamy soils amongst granitic rocks.

Notes: At Mount Greenly (refer Fig. 31) and some populations at Port Lincoln (e.g. Kirton Point), there is a long pedicellate form of this subspecies [pedicel (6-)9 - 15 mm long; calyx 6 - 9 mm long]. Elsewhere, the pedicel is usually up to 6 mm long. At Innes National Park (Yorke Peninsula), a few specimens have long pedicels (pedicel

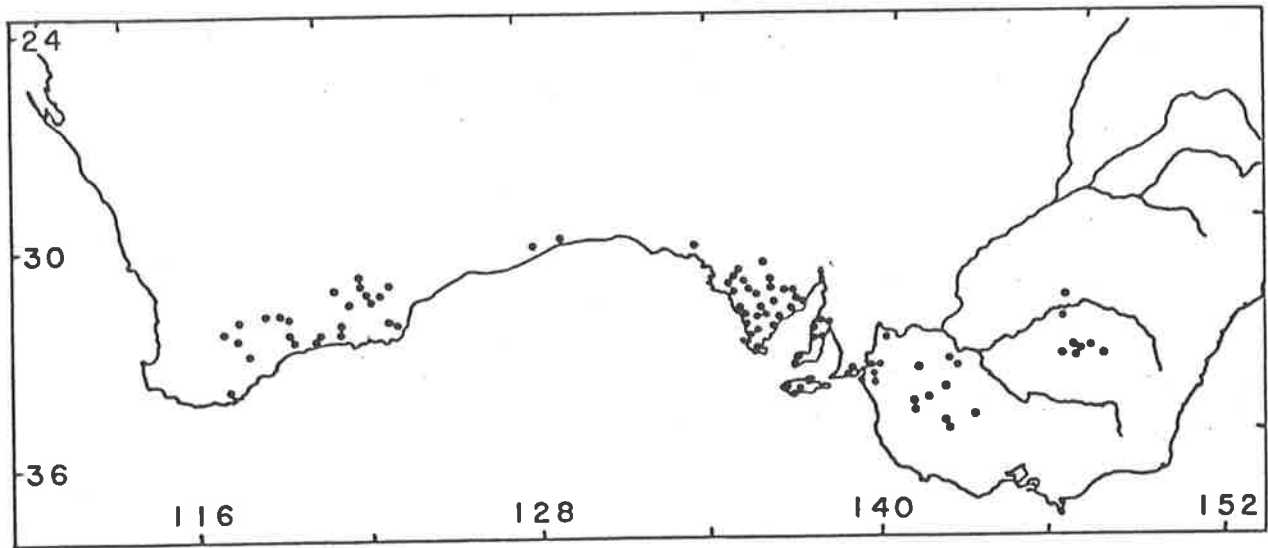


Fig. 57. Distribution map of *P. serpyllifolia*.

3 - 10 mm long; calyx 7 - 12 mm long). However, when the calyx is at least 9 mm long (in the latter population), the pedicel is usually less than 6 mm long. The taxonomic significance of this form is not known, but it does not appear to warrant formal taxonomic status. It is of interest to note that it appears to be restricted to quartzites and granitic gneisses rather than calcarenites (refer Johns, 1961). Specimens referable to this long pedicellate form are:

SOUTH AUSTRALIA. - [Eyre Peninsula] Central Mallee Plains & Dunes (Lincoln): Alcock 807, 23.x.1965, Proper Bay Road (AD); Black s.n., s. *dat.*, Port Lincoln (AD 96909025); Browne s.n., s. *dat.*, Port Lincoln (MEL 43407); Cleland s.n., 17.xii.1941, Proper Bay (AD 966031652); Dixon s.n., -.x.1883, Port Lincoln (AD 96928848); Wilson 410, 12.x.1958, Kirton Point (AD, UC); Wilson 411, 12.x.1958, Kirton Point (AD, M, SYD, UC); Specht 2706, 10.xi.1960, Flora & Fauna Reserve, 15 km SSE of Port Lincoln (AD); (Drummond): Conn 684, 20.ix.1979, Mt Greenly (AD); Williams 2103, 18.iv.1965, Mt Greenly (AD).

The smaller leafed individuals are often difficult to distinguish from the larger leafed specimens of ssp. *microphylla* in the Arno Bay, Hincks National Park, Kimba, and Bascombe Well regions of Eyre Peninsula (South Australia). However, the lamina of the former subspecies are usually not reflexed and their pedicels are usually longer than those of ssp. *microphylla*.

Selected specimens examined: (c. 95 collections)

SOUTH AUSTRALIA - [Yorke Peninsula] Southern Yorke Peninsula (Innes): Alcock 4539, 6.x.1974, southern end of eastern boundary, Innes National Park (AD); Conn 1106, 11.x.1981, Ethel Bay, Innes National Park (AD). - [Eyre Peninsula] Central Mallee Plains & Dunes (Kyancutta): Ising s.n., 9.ix.1938, Wudinna (AD 97650196); (Cleve): Alcock 1005, 7.xii.1966, Cleve Parklands (AD); (Hambidge): Barker 3639, 28.ix.1978, opposite turnoff

to Red Bank, near Arno Bay (AD); Wheeler 561, 3.x.1967, c. 7 km SW of Bascombe Well Homstead (AD); (Tooligie): Cleland s.n., 9.xi.1960, Tooligie Hill (AD); (Blue Range): Alcock 2202, 7.x.1968, c. 1.6 km N of Oak Amphitheatre, Blue Range (AD); (Hincks): Symon 6426, 11.x.1968, c. 3 miles N of Butler Gate on southern boundary of Hincks National Park (ADW); (Drummond): Wilhelmi s.n., -.i.1855, Lake Hamilton (HBG, MEL 41900, W); (Polda): Eichler 19373, 9.x.1967, Mt Wedge (AD); (Mt Cooper): B. Copley 4801, 10.ix.1975, Mt Cooper (AD); (Inkster): Canning 23603, 30.viii.1968, 15 miles from Poochera (AD); (Streaky Bay): Donner 2484, 13.x.1967, c. 40 km S of Streaky Bay (AD); (Marble Range): E. Jackson 3656, 1.x.1979, slopes of South Block (AD); (Yalunda): M. Clarke s.n., 5.x.1965, Hundred of Koppio (AD 966042262); (Lincoln): Richards s.n., -.x.1882, Port Lincoln road (MEL 43874).

2.2 *ssp. microphylla* (R. Br.) Conn *stat. nov.* - Fig. 58

Cryphia microphylla R. Br., Prodr. (1810)508; Sprengel, Linn. Syst. veg. ed. 16, 2(1825)704; Benth., Labiat. gen. spec. (1834)448; G. Don, Gen. hist. 4(1837)798; Walpers, Rep. bot. syst. 3(1844)764; Benth., in DC., Prodr. 12(1848) 559; Briq., in Engl. & Prantl, Nat. Pflanzenfam. 4, 3a (1895)220 [as *P. microphylla* R. Br., *nom. illeg.* - latter homonym of *P. microphylla* A. Cunn. ex Benth. (1834)]. - T y p e: R. Brown [J. Bennett 2359], *anno* 1802-5 [-.ii.1802], South Coast, Bay 10 [Pt Lincoln, (Stearn, 1960)], southern Eyre Peninsula, South Australia (BM *n.v.*; probable dupl. in E - upper left specimen, K *n.v.*). [refer Typification and p. 9]

P. microphylla A. Cunn. ex Benth., Labiat. gen. spec. (1834)454; G. Don, Gen. hist. 4(1837)800; Walpers, Rep. bot. syst. 3(1844)767; Benth., in DC., Prodr. 12(1848)562; Fl. austral. 5(1870)106; F.M. Bailey, Queensl.

fl. 4(1901)1204; Guilfoyle, Austral. pl. (1911)305; F. M. Bailey, Compr. cat. Queensl. pl. (1913)392; J. M. Black, Fl. S. Austral. ed. 1, 3(1926)492; Ewart, Fl. Victoria (1930)982; C. A. Gardner, Enum. pl. austral. occid. (1931)114; J. M. Black, Fl. S. Austral. ed. 2, 4(1957)738, 739; Hj. Eichler, Suppl. Black's fl. S. Austral. (1965)269; Blackall & Grieve, W. Austral. wildfl. 3(1965)594; J. S. Beard, Descr. cat. W. Austral. pl. (s. dat. [Oct. 1965])94 [as *P. microphylla* (R. Br.) A. Cunn.]; Galbraith, Wildfl. SE Austral. (1977)325; Althofer, Cradle of Incense (1978)74, 76 82. - L e c t o t y p e (here chosen): [A. Cunningham], s. dat., 'Eurylean [Euryalean] scrub' near Lachlan River, New South Wales (K - lower left specimen; probable isolect. A. Cunningham 225, anno 1817, 'Near Lachlan River. Euryalian [Euryalean] scrub' (typed label), New South Wales (MEL 43382 - centre right specimen). [refer Typification]

P. coccinea F. v. Muell., [Sec. gen report veg. colony (Oct. 1854) 13, *nom. nud.*] Trans. Phil. Soc. Victoria 1(1855)48, p.p., lectotype excl.; J. Bot. 8(1856)168, p.p.; Fragm. 6(1868)108, p.p.; *op. cit.* 9(1875)162, p.p.; Tepper, Trans. Roy. Soc. S. Austral. 3(1880)31, 32, 43; Tate, Trans. Roy. Soc. S. Austral. 3(1880)78; *op. cit.* 6(1883)145, 146, 165; F. v. Muell. Key Vict. pl. 2(1885)42; *op. cit.* 1(1887)385; Woolls, Pl. New S. Wales (1887)385; Tate, *op. cit.* 12(1899)111; Handb. fl. extratrop. S. Austral. (1890)151, 252; C. Moore, Handb. fl. New S. Wales (1893)353; F. v. Muell. & Tate, Trans. Roy. Soc. S. Austral. 16(1896)374; Dixon, Pl. New S. Wales (1906)232; Pescott, Nat. fl. Victoria (s. dat. [1914])99. [refer Typification for ssp. *serpyllifolia* p. 170].

P. arenicola S. Moore, J. Bot. 59(1921)247; C. A. Gardner, Enum. pl. austral. occid. (1931)114; Althofer, Cradle of Incense (1978)74.
H o l o t y p e: Sargent 858, 22.x.1920, Gnowangerup, Western Australia (BM).

P. microphylla f. *aeruginosa* J. H. Willis, Vict. Natural. 73(1957) 200; Ewart, Fl. Victoria (1930)983 (as '*P. chlorantha* F. v. Muell.');

J. H. Willis, Handb. pl. Victoria 2(1973)587. - H o l o t y p e: J. H. Willis s.n., 29.viii.1955, 'Rock Holes bore', NW Victoria, near South Australian border (MEL 43383). [refer Notes]

Branches moderately to densely hairy, (25-)30 - 170(-290) hairs/mm², hairs (0.09-)0.12 - 0.46(-0.52) mm long, recurved to reflexed, often appearing curled. Leaves usually clustered on short axes and arranged (unclustered) along long axes, sparsely to densely hairy, hairs similar to those of branches; leaves sessile or with petiole up to 0.3(-0.5) mm long; lamina ovate to oval, (1-)1.5 - 3(-3.8) x (0.5-)0.7 - 1.3(-2.7) mm [length to width ratio (1-)1.3 - 2.8(-3.6), distance of maximum width from base to total lamina length (0.07-)0.2 - 0.45(-0.7)], often reflexed, base obtuse to rounded, sometimes + truncate; lower surface usually glabrous, sometimes with an occasional hair; upper surface glabrous or sparsely to densely hairy, (0-)7 - 60(-113) hairs/mm², hairs similar to those of branches. Pedicel (0.8-)1 - 3.5(-4.8) mm long, sparsely to densely hairy, hairs similar to those of branches. Calyx (4.3-)5 - 7.5(-9.5) mm long, maroon or green; outer surface sparsely to densely hairy, rarely glabrous, (0-)17 - 40(-122) hairs/mm², hairs similar to those of branches; tube 3 - 5 mm long; lobes 1.5 - 2.2 mm long, c. 4 mm wide at base. Corolla bright pink to mid-red, often white basally, and/or with yellow tinge distally, or light metallic blue-green; tube 9 - 14 mm long.

Typification: Brown (1810) does not cite any specimens for *Cryphia microphylla* in the protologue. As for *C. serpyllifolia* (refer to Typification notes for ssp. *serpyllifolia*), the locality is imprecisely cited as '(M)' [South Coast]. The only source of additional information is Brown's original collection (as held at BM) because he does not mention this taxon in his manuscripts (microfilm copy held at AD).

For the same reasons as given under ssp. *serpyllifolia*, I have delayed the choosing of a lectotype until I have examined Brown's collections in the British Museum. J. Carrick (*in adnot.*) indicates that one collection of Brown's, held at the British Museum (which I have not examined): 'Brown 2359. *Cryphia microphylla*, Bay IX South Coast' - seems likely to be part of the original collection.

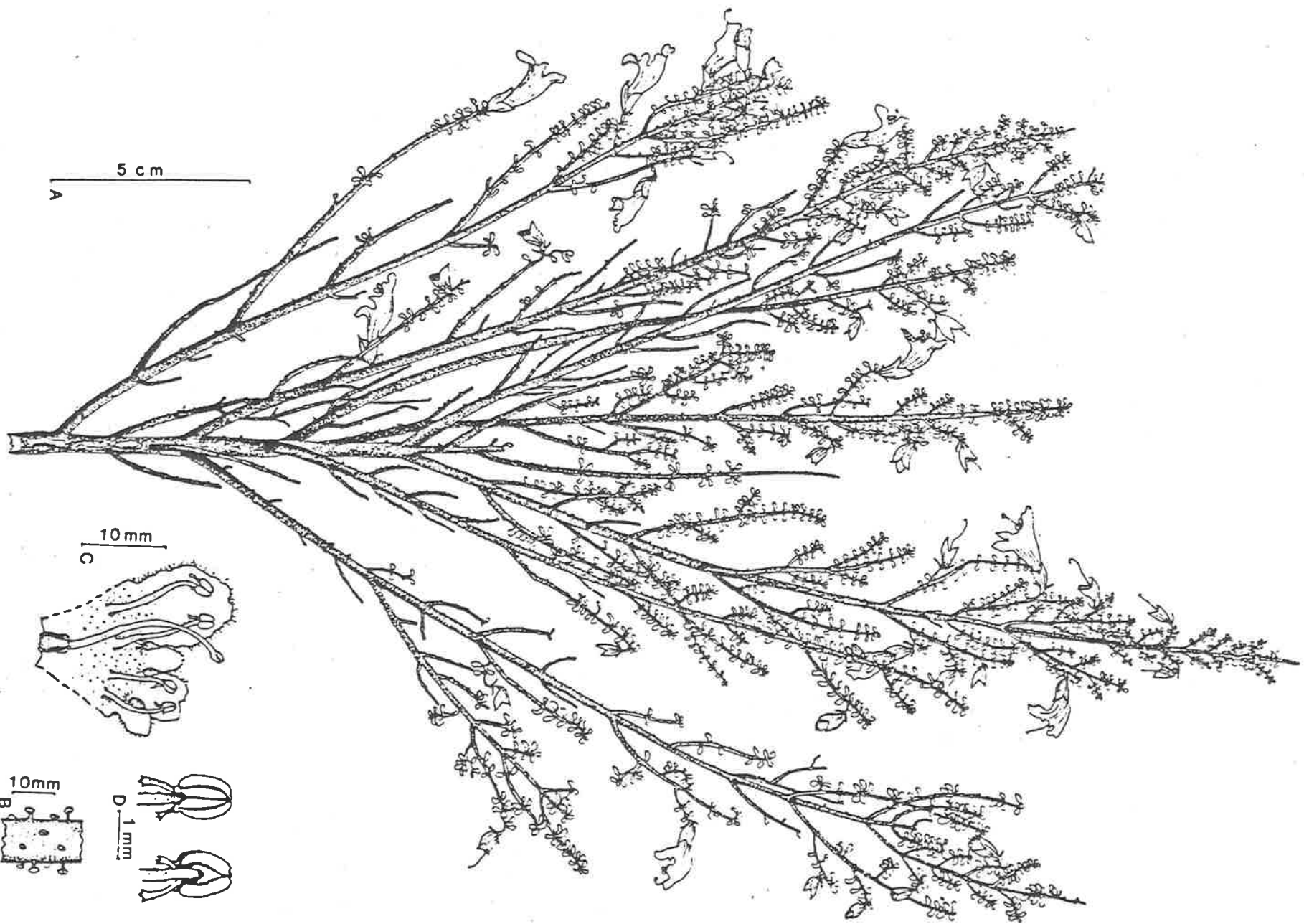
Since J. J. Bennett distributed duplicates of Brown's collections to the Royal Botanic Gardens, Kew, and to the Royal Botanic Garden, Edinburgh (and other herbaria) (Stearn 1960), the upper left specimen on a sheet at Edinburgh (E): 'R. Brown, *Iter Australiense*, 1802-5 Presented by direction of J. J. Bennett, 1876. No. Prostanthera microphylla? Genus inter Prostantheram Scutellariam. South Coast Bays 9 & 10', can probably be regarded as a syntype, and hence, may be chosen as an isolectotype.

A. Cunningham 225 (MEL 43382) is morphologically similar to Anonymous [A. Cunningham] (K). Furthermore, the locality information given in the protologue (Bentham 1834) and on the labels of the above two collections are similar. Therefore, the centre right specimen of A. Cunningham 225 (MEL 43382) is here regarded as a probably isolecotype of P. microphylla A. Cunn. ex Benth.

The MEL material of A. Cunningham 225 is a mixed collection which has subsequently been mounted on separate sheets. MEL 43382 contains four specimens of P. serpyllifolia ssp. microphylla, MEL 61361 has one specimen of P. aspalathoides, and MEL 613622 has one specimen of an unidentified species of Prostanthera section Prostanthera {possibly P. scutellarioides (R. Br.) Briq.}.

Distribution: New South Wales - Central Western Slopes, South Western Plains; Victoria - western Northern Plains, Mallee; South Australia - Murray Mallee, Mt Lofty Block (incl. Kangaroo Island), Yorke and Eyre Peninsulas; Western Australia - Eremaean: south-eastern Eucla, southern Coolgardie; South-West: Eyre, Roe, south-eastern Darling, southern Avon.

Fig. 58. *Prostanthera serpyllifolia* ssp. *microphylla*.
A. twig and flowers; B. glandular trichomes of branch;
C. open corolla; D. stamens - ventral and dorsal views
(all Carrick 3192).



Ecology: Refer species. At Cape Cassini (Kangaroo Island), it occurs on limestone cliffs in shallow skeletal soils. Between Kimba and Whyalla it occurs in *Triodia* dominated grasslands (Phillips 160).

Notes: Most authors have applied a much narrower concept to *P. coccinea* than did Mueller. Although the exact concept used is not always clear, it seems that most authors regarded *P. coccinea* as very closely related to *P. microphylla*.

This subspecies is characterized by the small, usually ovate leaves which are recurved to reflexed. The calyx is consistently densely hairy in all Victorian populations and sparsely to densely hairy in New South Wales populations. In South Australia, the calyx is sparsely to densely hairy in those populations east of Murray Bridge (with few exceptions), Kangaroo Island (except at Cape Cassini), and central and northern Yorke Peninsula. Populations on northern Eyre Peninsula mostly have a hairy calyx, while those further South are more variable, such that the calyx is frequently glabrous. The populations in Western Australia are similar to those of Eyre Peninsula.

P. microphylla f. *aeruginosa* is reduced to synonymy because it is merely a colour form in a taxon which is extremely variable with respect to corolla colour.

Selected specimens examined: (c. 230 collections)

NEW SOUTH WALES - Central Western Slopes: Kaspiew 1342, 24.xii.-, Cowra (F).- South Western Plains: Whaite 2726, 21.ix.1963, 31 miles N of Hillston on Cobar road (NSW).

VICTORIA - Mallee: Beauglehole 1064, -.x.1948, Hattah Lakes National Park (AD). - Northern Plains: Dalton s.n., 27.ix.1911, Dimboola District (LE); Walter s.n., 29.i.1889, West Wimmera (GH, MO, P).

SOUTH AUSTRALIA - Murray Mallee: Upper Murray Lands (Pata): Specht 2360, 14.x.1960, c. 80 km SSE of Renmark (AD). - Northern Calcarene Ridges & Plains (Coonalpyn): Beauglehole 17538, 26.x.1967, c. 8 km W of Coonalpyn (AD); (Catnana): Grivell s.n., 1.x.1968, Yumali (AD 97050460) (Coorangie): Sharrad 241, 4.x.1959, Malinong (AD). - South East Mallee Heathlands (Billiatt): van der Sommen s.n., -.xi.1974, c. 16 km S of Paruna (AD 97449148); (The Big Desert): Symon 8660, 22.x.1973, Scorpion Springs Conservation Park (AD, ADW); (Moorlands): Williams 1037, 2.x.1960. c. 50 km SSE of Murray Bridge (AD); (Karoonda): A. Burbidge s.n., 26.ix.1971, c. 25 km E of Murray Bridge (AD 97142004). - Mt Lofty Block: Peninsula Uplands (Sandergrrove): Ising s.n., -.vi.1925, Kinchina (AD 97249327). - Kangaroo Island (Stokes Bay): Conn 1073, 13.xi.1980, Cape Cassini (AD); (Parndana): Eichler 15172, 3.xi.1958, Cape Borda (AD); (Gantheaume): B. & H. Conn 1089 - 1092, 14.xi.1980, Kelly Hill Cave (AD). - Yorke Peninsula: Gulf Plains (Barung): Donner 1871, 12.x.1966, c. 11 km S of Bute (AD); (Boor Plains): Phillips s.n. (CBG 23839), 2.x.1965, 16 miles from Kadina towards Port Wakefield (AD); (Weetulta): B. Copley 4091, 15.ix.1973, c. 6 km SE of Moonta (AD). - Southern Yorke Peninsula (Urania): Gill 152, 29.ix.1890, near Maitland (MEL); (Corny): Wrigley WA/68 7745, 24.xi.1968, 12 miles from Corny Point (AD). - Western Pastoral: Gawler Uplands (Gawler): Lay 686, 29.ix.1972, c. 5 km S of Yarna Homestead (AD). - [Eyre Peninsula] Northern Myall Plains (Buckleboo): Rohrlach 625, 7.x.1959, 40 km WNW of Kimba (AD); (Thurlga): Warnes s.n., 1.ix.1968, Thurlga Station (AD 96850109); (Middleback Range): Phillips 160, 29.viii.1968, 41 miles from Whyalla towards Kimba (CBG 23621).-

Central Mallee Plains & Dunes (Ironstone Hill): Eichler 19193, 28.viii.1967, 11 km E of Refuge Rockhole (AD); (Kimba): Caulfield 236, 29.ix.1955, Kimba (AD); (Pinkawillinie): Orchard 2138, 15.viii.1969, c. 56 km E of Kimba (AD, UC); (Kyancutta): Chinnock 2790, 4.x.1975, 29 km NW of Minnipa (AD); (Cleve): Alcock 632, 2.ix.1965, c. 17 km N of Arno Bay (AD); (Darke Peake): Ising s.n., 30.viii.1935, Darke Peake (AD 97249342); (Hambidge): Kraehenbuehl 2061, 9.x.1966, Hambidge National Park (AD); (Tooligie): Cleland s.n., 9.xi.1960, Tooligie Hill (AD 966071287); (Blue Range): Wheeler 748, 6.x.1968, slopes of Verran Hill (AD); (Hincks): Symon 6192, 8.x.1968, along North Diagonal road, Hincks National Park (ADW). - Southern Highlands & Plains (Butler): Whibley 7426, 2.x.1980, 11 km NNE of Ungarrd (AD); (Peake Bay): Wilhelmi s.n., *s. dat.*, Tumby Bay (MEL 43385); (Mt Gawler): Whibley 1961, 27.viii.1967, c. 8 km NE of Port Neill (AD); (Lincoln): J. Veitch for Beauglehole 17574, *anno* c. 1950, Port Lincoln (AD). - West Coast (Drummond): J. Veitch s.n., 3.xi.1949, Mt Hope (AD 966051161); (Polda): Ising s.n., 16.ix.1938, Venus Bay (AD 97650199).

WESTERN AUSTRALIA - Eremaean: south-eastern Eucla: George 8519, 15.x.1966, 3.5 miles E of Eucla (PERTH). - southern Coolgardie: Armitage 522, 4.x.1973, 68 miles S of Norseman (PERTH). - South West: southern Avon: Gardner 1998, 3.ix.1923, Dumbleyung (PERTH); Roe: Royce 8882, 23.x.1969, 3 miles N of GrassPatch (PERTH); south-eastern Darling: Cronin s.n., *anno* 1892, near King George's Sound (MEL 43868); Eyre: Royce 9302, 24.x.1970, Coppermine Creek, Fitzgerald River National Park (PERTH).

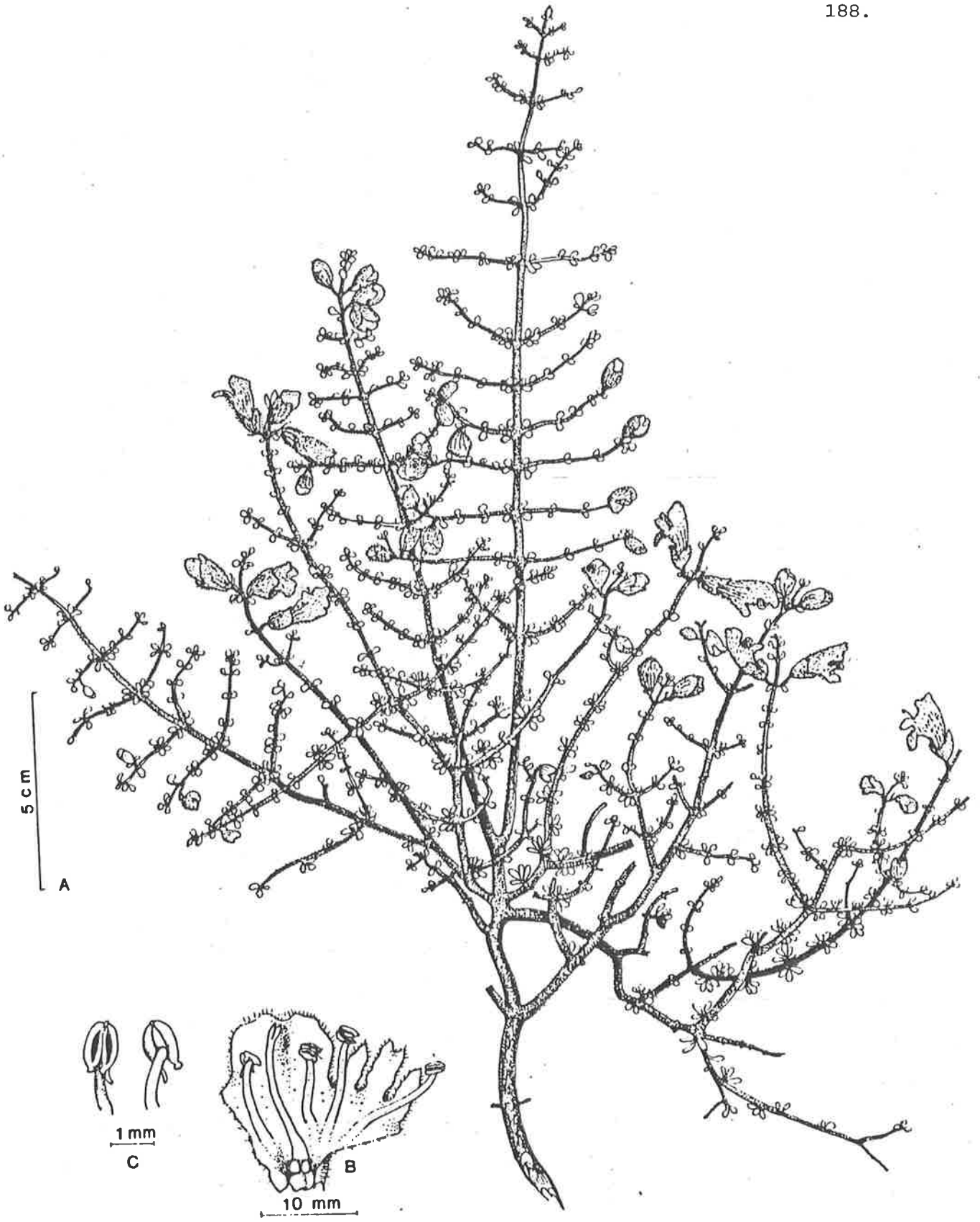
3. *Prostanthera patens* Conn, sp. nov. - Figs 59 & 68

Species nova sectionis Klanderiae. Frutices parvi. Rami et ramuli spiniformes, moderate tomentosi, glandiferi. Folia dense tomentosa; petiolus usque ad 0.3(-0.5) mm. longus; lamina ovata usque ovalis, 1.4 - 2.3 mm. longa, 0.8 - 1.5 mm. lata, basi obtusa usque rotundata, margine integro, recurvo, apice obtuso usque rotundato. Pedicellus florum 1.5 - 3.2 mm. longus, dense tomentosus, bracteolis circa 1 mm. e basi calycis affixis, mox caducis. Calyx (5-)6 - 7.7 mm. longus, extra et intra plus minus dense tomentosus, pilis 0.2 - 0.3 mm. longis; tubus 4 - 4.5 mm. longus; lobi plus minusve deltoidei, 2.4 - 3.5(-4) mm. longi, circa 3.5 (-5.5) mm. lati, margine integro, apice obtuso usque late rotundato. Corolla 22 - 27 mm. longa, aurantiaca usque rubra, extra moderate usque dense tomentosa, intra in partibus distalibus sparsim tomentosa; tubus 11 - 17 mm. longus; lobus abaxiali-medianus late oblongus, 4 - 5.5 mm. longus, recurvus, margine integro, apice obtuso, saepe emarginato, sinu circa 0.2 mm. longo, lateralibus angusto-deltoideis usque plus minusve oblongis, 3 - 4 mm. longis, recurvis, margine integro, apice obtuso, saepe emarginato, sinu circa 0.2 mm. longo, adaxiali-mediano late obovato, 5 - 9 mm. longo, margine integro, apice rotundato, emarginato, sinu 0.2 - 0.6 mm. longo. Stamina circa 8 mm. e basi corollae affixa; filamenta 6 - 8 mm. longa; antherae circa 1.5 mm. longae, appendice 1 - 1.7 mm. longa. Pistillum 22 - 27 mm. longum; ovarium circa 0.6 mm. longum; stylus 20 - 25 mm. longus; lobis stigmatis 0.4 - 0.5 mm. longis. Fructis non visis.

Holotypus: Ashby 5209, 24.viii.1975, east of Pindar, Avon botanical district, Western Australia (AD).

Small shrub, height unknown. Branches + terete, stiff, spine-like, moderately hairy, particularly at nodes, (34-)40 hairs/mm², hairs 0.1 - 0.2 mm long, + appressed [base of hair to first bend c. 0.03(-0.05) mm; greatest distance hair from branch up to 0.05 mm], translucent to white; sparsely to moderately glandular, glands globular, raised. Leaf bearing

Fig. 59. *Prostanthera patens*. - A. twig and flowers; B. open corolla; C. stamens - ventral and dorsal views (all Alpin 2551).



branches short to long. Leaves clustered or arranged along branches, densely hairy, 128 - 220 hairs/mm², sparsely to moderately glandular, up to 20 glands/mm², glands slightly raised; petiole + terete, up to 0.3(-0.5) mm long; lamina ovate to oval, often appearing + oblong because margin recurved, 1.4 - 2.3 x 0.8 - 1.5 mm [length to width ratio (0.19-)0.25 - 0.43], base obtuse to rounded, margin entire, recurved, apex obtuse to rounded; venation indistinct, midrib sometimes slightly raised on abaxial surface. Pedicel 1.5 - 3.2 mm long, + terete, usually maroon, densely hairy, hairs 0.1 - 0.2 mm long, appressed to suberect, white; prophylls inserted approximately halfway along pedicel [rate of length from prophyll to base of pedicel to length from prophyll to base of calyx 0.8 - 1.3], not overlapping with base of calyx, soon deciduous, narrow-oblong, 0.8 - 1.3 x 0.3 - 0.5 mm [length to width ratio 1.6 - 4], hairy, margin entire, apex obtuse. Calyx (5-)6 - 7.7 mm long, green to maroon; outer surface densely hairy, 128 - 215 hairs/mm², hairs 0.2 - 0.3 mm long, + appressed, white; inner surface moderately to densely hairy, 56 - 185 hairs/mm²; tube 4 - 4.5 mm long; lobes + triangular, 2.4 - 3.5(-4) mm long, c. 3.5(-5.5) mm wide at base, margin entire, apex obtuse to broadly rounded. Corolla 22 - 27 mm long, orange to pale red basally, red distally; outer surface moderately to densely hairy, hairs c. 0.2 mm long, with a few scattered glands to moderately glandular; inner surface glabrous at base, sparsely hairy above, especially on lobes; tube 11 - 17 mm long; abaxial median lobe broadly oblong, 4 - 5.5 mm long, recurved, margin entire, apex obtuse, often emarginate, sinus c. 0.2 mm long; lateral lobes narrow-triangular to oblong, 3 - 4 mm long, recurved, margin entire, apex obtuse; adaxial median lobe-pair broadly obovate, 5 - 9 mm long, margin entire, apex rounded, emarginate, sinus 0.2 - 0.6 mm long. Stamens inserted c. 8 mm above base of corolla; filaments 6 - 8 mm long, with scattered glandular trichomes; anthers 1.5 mm long, base of lobes with acumen, acumen c. 0.2 mm long, connective basally extended to form an appendage, appendage 1 - 1.7 mm long. Pistil 22 - 27 mm long; ovary c. 0.6 mm long, diameter at base 1 -

1.2 mm, lobes 0.3 mm long; style 20 - 25 mm long, sometimes with a faint median groove; stigma lobes 0.4 - 0.5 mm long. Fruits not known.

Distribution: Western Australia (Eremaean: Austin; South-West: Avon)

Ecology: Little known of associations and geology. "Growing with *Wrixonia*" (Ashby 5220), "Not in heath country" (Ashby 5209), "ironstone scree on slope of B.I.F. ridge" (Blockley 488).

Notes: This new species was included in the *P. laricoides* complex as a result of various numerical analyses (in particular, refer Figs 6 & 8). However, numerical analysis (pp. 76-82) and a study of morphological variation (pp. 112-126) in this complex indicate that *P. patens* can be distinguished by many characters from the other species of the complex. The distinctness of *P. patens* is clearly illustrated in Figs 16-19. Therefore, the inclusion of this species in this complex is inappropriate. Its closest affinities appear to be with *P. serpyllifolia*. Both species have small leaves and long anther appendages. The spine-like branches of *P. patens* give this species a distinctive habit and the hairy inner surface of the calyx readily distinguish it from *P. serpyllifolia*.

Specimens examined:

WESTERN AUSTRALIA - Eremaean: Austin: Alpin 2551, 26.viii.1963, 25 miles N of Paynes Find (PERTH); Beard 2653, 10.viii.1965, N of Payne's Find (KP).- South-West: Avon: Ashby 5209, 24.viii.1975, E of Pindar (AD); Ashby 5220, 31.viii.1975, between Perenjori and the Inland Highway (Paynes Find Road) (AD); Blockley 488, 27.viii.1967, S of Paynes Find on Great Northern Highway (KP); Burns 1037/2, -.x.1966, Morawa (PERTH); Lullfitz 2427, 9.ix.1963, 22 miles from Sandstone towards Mt Magnet (KP).- No locality: Steenbohm s.n., -.x.1961, s. *loc.* (PERTH).

4. *Prostanthera calycina* F. v. Muell. ex Benth. - Fig. 60

Prostanthera calycina F. v. Muell. ex Benth., Fl. austral. 5(1870) 107; Tate, Trans. Roy. Soc. S. Austral. 3(1880) 78; *op. cit.* 12(1889)111; Handb. fl. extratrop. S. Austral. (1890)151, 252; Briq., in Engl. & Prantl, Nat. Pflanzenfam. 4, 3a(1895)220 (as 'P. calycina'); J. M. Black, Fl. S. Austral. ed. 1, (1926)492; *op. cit.* ed. 2, 4(1957)738; Galbraith, Wildfl. SE. Austral. (1977)325; Althofer, Cradle of Incense (1978)78, 80, 82. -
L e c t o t y p e (here chosen): Warburton s.n., s. dat., Venus Bay, Eyre Peninsula, South Australia (MEL 41899). [syntypes refer typification, p. 190]

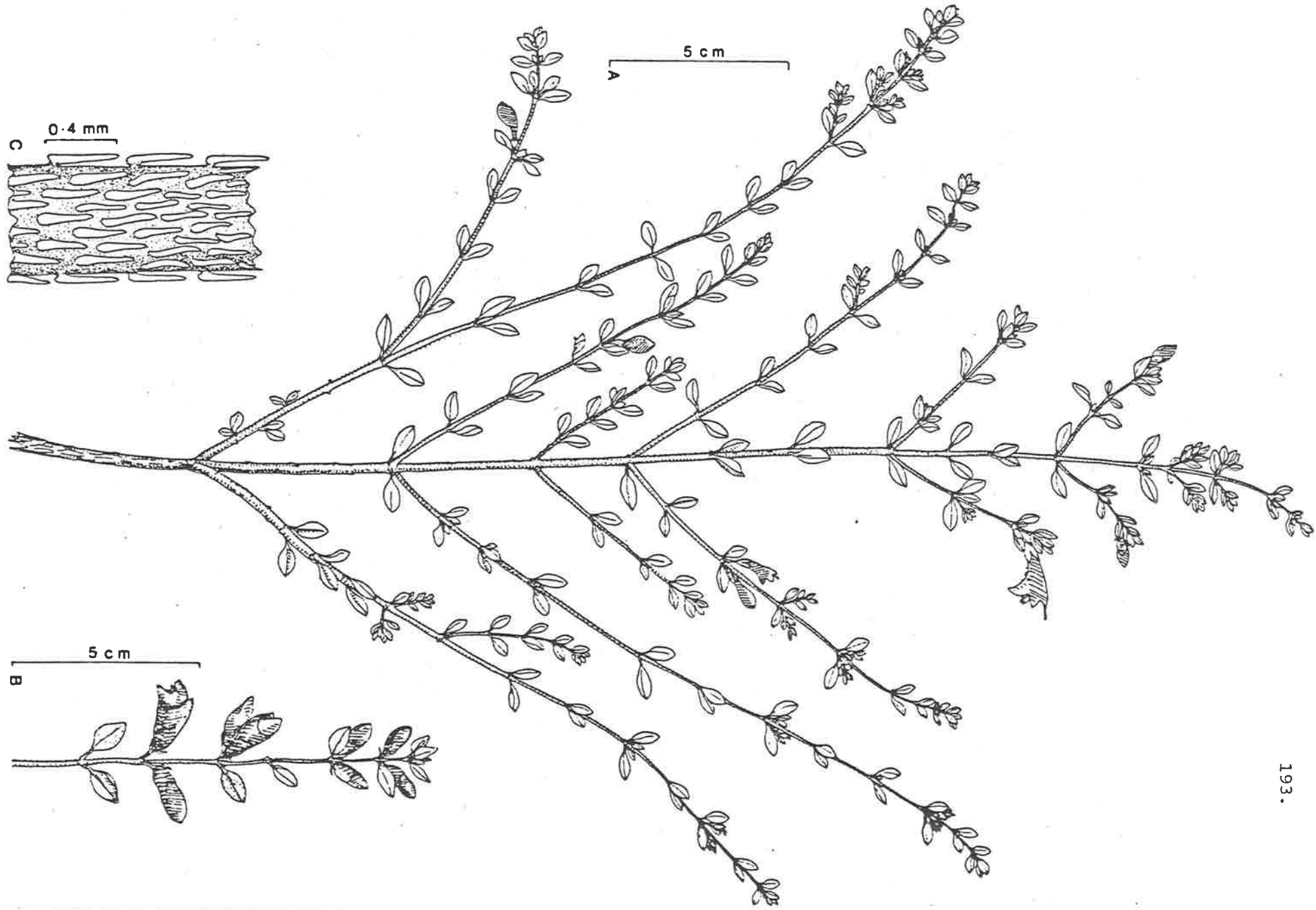
Small ± prostrate shrubs, c. 0.5 m high. Branches ± terete, often slightly flattened distally, often with faint grooving on internodes (from one leaf axis to the next node alternatively) moderately to densely hairy, 54-117 hairs/mm², hairs (0.1-)0.3-0.4(-0.5) mm long, stiff and straight (for most of length), appressed [Base of hair to first bend usually less than 0.05 mm long; greatest distance hair from stem is less than 0.8(0-1) mm], hair apex directed towards distal part of branches; sparsely glandular, up to 18 glands/mm². Leaves arranged along the axis and branches, not clustered on short shoots, usually sparsely, rarely densely hairy, occasionally glabrous, hairs similar to those of branches; petiole 0.8-1.4 mm long ± flattened, densely hairy, similar to those of branches; lamina oval to ovate-oblong, 4-14 x 3-5 mm [length to width ratio 1.4-3.8, ratio of distance of maximum width from base to total lamina length 0.4-0.6], base obtuse to subattenuate, margin entire, apex obtuse to rounded, hairs ± restricted to midrib and margin of lower surface, ± confined to margin and apex of upper surface, up to 30 hairs/mm², similar to those of branches; venation indistinct or not visible.

Pedicel 2.5-4.5(-7) mm long, often maroon, densely hairy, hairs similar

to those of branches; prophylls inserted at base of calyx, hence overlapping basal part of calyx, narrow-oblong to \pm oblong, 1.5-4 x c. 0.5 mm [length to width ratio (3-)5-7.5], slightly concave, densely hairy, at least near base, sparsely hairy at apex, hairs sometimes restricted to margin, apex obtuse. Calyx 8-14 mm long, usually maroon, sometimes green; outer surface sparsely to moderately hairy, particularly along veins, up to 15 hairs/mm², hairs similar to those of branches, moderately glandular on outer surface, 9-17 glands/mm²; inner surface glabrous; tube 6-8 mm long; lobes \pm triangular, 4-6 mm long, 5-7 mm wide at base, apex obtuse to broadly rounded. Corolla 17.5-22 mm long, red; outer surface distally sparsely to moderately hairy, hairs c. 0.1 mm long; inner surface glabrous; tube 13-15 mm long; abaxial median lobe \pm obovate, c. 4 mm long, c. 3 mm wide, \pm recurved to reflexed, margin entire, apex rounded; lateral lobes narrow, \pm triangular to ovate, c. 3 mm long, \pm recurved to reflexed, margin entire; adaxial median lobe-pair broadly triangular, c. 5 mm long, margin entire, apex obtuse, sometimes slightly emarginate, sinus up to 0.2 mm long. Stamens inserted c. 8.5 mm above base of corolla; filaments c. 5.5 mm long, with a few scattered minute glandular trichomes; anthers 1.5-2 mm long, base of lobes with minute acumen, acumen c. 0.06 mm long, connective extended to form a short basal appendage, appendage (0.1-)0.4-0.8 mm long. Pistil 12-15 mm long; ovary 0.5-0.7 mm long, diameter c. 0.6-1 mm at base, lobes small, c. 0.1 mm long; style 11-14 mm long, sometimes with faint median groove; stigma lobes up to 0.3 mm long. Fruit unknown.

Typification: Bentham (1870) cited two collections in the protologue of *P. calycina* (*viz.* Wilhelmi, Port Lincoln; and Warburton, Venus Bay). The specimen collected by Warburton (as held at MEL) has one mature

Fig. 60. *Prostanthera calycina*. - A. twig and flowers
(Weber 6210); B. twig and flowers; C. hairs on branch
(all Warburton s.n.).



(open) corolla, while the Wilhelmi collection (as held at MEL) has old calyces and a few young buds. Both collections were examined by Bentham. Since Bentham described the corolla in the protologue, the Warburton collection (which has mature corollas) is here chosen as the lectotype.

Distribution: South Australia - western coastal and southern Eyre Peninsula: West Coast (Polda, Drummon, Edillie, Lincoln), Central Mallee and Dunes (Ceduna).

Ecology: Occurs on calcarenite ridges and in sandy loams of undulating calcreted plains in Mallee communities. Commonly associated with *Eucalyptus incrassata*, *E. oleosa*, *E. socialis*, and frequently with *Melaleuca*, *Pittosporum*, *Santalum acuminatum*, and various shrubs (such as *Grevillea*, *Hakea* and *Spyridium*).

Notes: This species has a very distinctive hair type which is not found in any other taxon of this section (sect. *Klanderia*). The hairs are appressed, straight for most of their length, stiff, and directed towards the distal part of the organ on which they occur. It has its closest affinities with *P. serpyllifolia*. The relatively large calyx is a useful secondary feature which distinguishes this species from *P. serpyllifolia* ssp. *microphylla*. For further details on the relationship of this species with *P. serpyllifolia*, refer 'Numerical analysis of the *Prostanthera calycina* - *P. microphylla* - *P. serpyllifolia* complex' and 'Morphological variation in the *Prostanthera calycina* - *P. microphylla* - *P. serpyllifolia* complex'.

This species is conservationally possibly at risk (Risk Code = 2K, [Conn, in] Leigh *et al.* 1981, pp. 49 & 86).

Selected specimens examined: (15 collections)

SOUTH AUSTRALIA - [Eyre Peninsula] Central Mallee & Dunes (Ceduna):

Richards s.n., *anno* 1883, Fowler's Bay (MEL 41898). - West Coast (Polda):

Richards s.n., *anno* 1887, between Port Lincoln & Streaky Bay (MEL 43873);

(Drummond): Wilhelmi s.n., -i.1855, Lake Hamilton (HBG, MEL 41900, W);

(Edillie): Phillips 6653, 27.viii.1964, 1 mile from Wanilla, towards North

Shields (AD); (Lincoln): Wilhelmi s.n. s. dat. [*anno* 1855], Port Lincoln

(MEL 41901).

5. *Prostanthera aspalathoides* A. Cunn. ex Benth. - Figs 61 - 63

Prostanthera aspalathoides A. Cunn. ex Benth., Labiat. gen. spec. (1834)453; G. Don, Gen. hist. 4(1837-8)799; D. Dietr. Syn. pl. 3(1842)427; Walpers, Rep. bot. syst. 3(1844)767; Benth. in DC., Prodr. 12(1848)562; Fl. austral. 5(1870)107; Briq., in Engl. & Prantl, Nat. Pflanzenfam. 4, 3a(1895)220; J. M. Black, Fl. S. Austral. ed. 1, 3(1926)491; Ewart, Fl. Victoria (1930)982; J. M. Black, Trans. Roy. Soc. S. Austral. 55(1931)141; Fl. S. Austral. ed. 2, 4(1957)738, t. 1057; Hj. Eichler, Suppl. Black's fl. S. Austral. (1965)269; Blombery, A guide to native Austral. pl. (1967) 309; Cochrane *et al.*, Flowers and plants of Victoria (1968)53, fig. 128; Galbraith, Wildfl. SE. Austral. (1977)325, pl. 27; Holliday & Watton, Austral. native shrubs (1978)182 & 183, Althofer, Cradle of Incense (1978) 74, 75, 77, 79, 82 & 83. - L e c t o t y p e (here chosen): A Cunningham 224, 24.v.1817, 'Dwarf shrub, Mr Oxley's first expedition, down Lachlan River, on barren rugged hills' (K; probable isolecto: A. Cunningham 224, anno 1817, New South Wales, near Mount Aiton, BM, MEL 42918). [refer Typification]

P. coccinea [non F. v. Muell., Trans. Phil. Soc. Victoria 1(1855)48] F. v. Muell., Fragm. 6(1868)108, p.p. lectotype excl. [refer 'Typification' for *P. serpyllifolia* ssp. *serpyllifolia*, p. 172]

P. eriocalyx Gand., Bull. Soc. Bot. France, 65(1918)6. - H o l o t y p e : Walter s.n., -.x.1892, 'N. West Victoria' (LY; iso in NSW). [refer Tindale in McGillivray (1973, p. 352)]

P. patula Gand., *loc. cit.* - H o l o t y p e : Sutton s.n., -.x.1905, 'Australia. Wimmera, Victoria' (LY; iso in NSW). [refer Tindale in McGillivray (1973, p. 352)]

Small shrub, 0.3 - 1 m high. Branches ± terete, densely hairy, hairs c. 0.1 mm long; glandular. Leaf bearing branches short to long, when short, leaves often densely clustered at nodes of axis, when long, branches 2 - 4 mm long, then leaves spread out along branches. Leaves glabrous or sparsely

tomentose, 0 - 40(-66) hairs /mm², hairs (0.05)0.1 - 0.3 mm long, glandular, 15 - 50(-100) glands /mm²; petiole absent or if present, then less than 0.5 mm long; lamina terete to compressed-terete, oblong-linear, linear-oval to linear-oblongate, (1.5)2 - 6(-10) x 0.5 - 1 mm, base slightly attenuate, margin entire, recurved when lamina subterete, apex obtuse to rounded; venation not visible. Pedicel 2 - 3 mm long, tomentose to glabrous; prophylls inserted near distal end of pedicel, and so overlapping basal part of calyx, oblong-linear, 2 - 3 mm long, concave, abaxial surface sparsely tomentose, especially near margin, adaxial frequently sparsely fimbriate, apex obtuse. Calyx 5 - 7 mm long; outer surface sparsely to densely hairy, rarely glabrous; inner surface glabrous; tube 3 - 4 mm long; lobes broadly lanceolate to ± triangular, 2 - 3 mm long, c. 3 mm wide at base, apex obtuse. Corolla 10 - 20 mm long, red, pink-red, orange, rarely yellow; outer surface distally hairy; inner surface usually with dark red spots on lower lips; tube 8 - 11 mm long, outer surface distally sparse to densely hairy; lobes sparsely hairy on outer surface, inner surface glabrous; abaxial median lobe obovate, slightly bilobed, 2 - 3 mm long, 2 - 4 mm wide at base, margin entire to irregular, apex obtuse to slightly bilobed, sinus up to 1 mm long; lateral lobes ovate to oblong-ovate, or ± triangular, 1.5 - 3(-4) mm long, 1.5 - 2(-3) mm wide at base; adaxial median lobe-pair ± ovate, often slightly 3-lobed, 5 - 8 mm long, 6 - 8 mm wide at base, apex obtuse, sometimes emarginate, sinus up to 0.5 mm long. Stamens inserted c. 10 mm above base of corolla; filaments 6 - 8 mm long, with broad-deltoid glandular trichomes; anthers 1.5 - 2 mm long, although appendage appearing absent, one side of connective usually extended to form a minute basal appendage, appendage up to 0.3(-0.5) mm long, sometimes with broad-deltoid trichomes on appendage. Pistil 17 - 18(-25) mm long; ovary 1 - 1.5 mm long, diameter c. 1 mm at base, lobe small, c. 0.3 mm long; style 15 - 20(-23) mm long; stigma lobes up to 1 mm long. Mericarps

2 - 2.5 mm long, distally 0.5 - 1 mm extended beyond base of style.

Typification: Bentham (1834) cited 'A Cunningham' as the collector of the type of *P. aspalathoides*. There is close agreement between the brief description provided in the protologue and Cunningham 224. Furthermore, the herbarium label on the K sheet (p.185) corresponds with the locality given in the protologue ('in collibus aridis sterilibus ad fluvium Lachlan'; Bentham, 1834, p. 454). Therefore, Cunningham 224 (K) is here chosen as the type of this species.

Distribution: Queensland (Maranoa - R. Jordan s.n., -.viii.1953, St George), New South Wales (Central Western Slopes, South Western Plains, South Far Western Plains), Victoria (Mallee, Northern Plains) and South Australia (Murray Mallee, Mt Lofty Block - (incl. Kangaroo Island), Gulf Plains - [Yorke Peninsula], Northern Myall Plains and Central Mallee and Dunes - [Eyre Peninsula]).

Ecology: Occurs in open Mallee communities (*Eucalyptus incrassata*, *E. socialis*) with open understorey commonly of *Melaleuca lanceolata*, *M. uncinata*, *Triodia* sp. and other heathland plants (Barker 4133; Beaglehole 28862, 29015, 29555), occasionally with *Callitris preissii* (Conn 1040; Melville 1085), frequently in roadside communities. It occurs on sandstones and shales (Melville 1310), amongst sandstone outcrops (Beaglehole 29015), on red sandy loams (Conn 1042), overlying granite (Brickhill s.n., 3.x.1979; Conn 775) or in shallow, calcareous soils (Conn 1043). Often in sandy soils with high 'buckshot' gravel content (Conn 703), less commonly occurring in soils with high clay content.

Fig. 61. *Prostanthera aspalathoides*. - A. twig and flowers;
B. open corolla; C. stamens - ventral and dorsal views (all
Carrick 2944).



Fig. 62. *Prostanthera aspalathoides*. - A. twig and flowers;
B. open corolla; C. stamens - ventral and dorsal views (all
from cultivated material, Adelaide Botanic Gardens).



Note: There is considerable variation in the size of the leaves of *P. aspalathoides*. For example, Ising s.n., 9.ii.1937 (AD 966081719); Kraehenbuehl 913 (AD); and Wheeler 457 (AD, MEL) have very small leaves (2 - 2.5 x c. 0.7 mm) similar to *P. serpyllifolia* ssp. *microphylla*, whereas Blaylock 1306 (A, AD) has very long leaves (11 - 20 x 0.6 - 1.2 mm). In the Waikerie and Billiatt National Park areas of South Australia, the leaves are slightly flattened narrow-elliptic, similar to *P. serpyllifolia* ssp. *serpyllifolia*. However, *P. aspalathoides* usually has the leaves crowded on short shoots, e.g. Aitken s.n., 24.x.1974 (AD 98108051, MEL), Carrick 3306, 3307 (AD, MEL), and Whibley 3645 (AD, MEL), whereas those of *P. serpyllifolia* are arranged along the long axes.

This species is closely related to *P. florifera* (refer pp. 193 - 208). It differs from the latter by having a much shorter anther appendage (up to 0.5 mm long cf. 1 - 2.5 mm long for *P. florifera*) and usually smaller calyces (5 - 7 mm long cf. 7 - 12 mm long for *P. florifera*).

Selected specimens examined: (420 collections)

NEW SOUTH WALES. - Central Western Slopes: Tindale s.n., -.x.1963, 5 miles from W. Wyalong (A, AD 96401023, NSW 63772). - South Western Plains: Conn 760 - 768, 22.viii.1980, 12 - 15 km E of Rankin Springs (AD, MEL). - South Far Western Plains: Phillips CBG 23840, 15.ix.1965, 9 miles from Balranald (AD 97001168).

VICTORIA. - Mallee: Beauglehole 28862, 2.x.1968, Dattuck track, Wyperfeld National Park (AD). - Northern Plains: B. & H. Conn 703, 31.x.1979, 22 km NNE of Bendigo (AD); Morris 1527, 14.x.1926, Wederburn (NSW).

SOUTH AUSTRALIA. - Murray Mallee: Upper Murray Lands (Parcoola): Munir 5059, 5060, 26.ix.1971, c. 16 km N of Overland Corner (AD); (Renmark): Reid s.n., 26.iii.1958, Calperum station (AD 97348358); (Holder): Donner 3693, 26.ix.

1971, c. 15 km W of Waikerie (AD); (Blanchetown): Barker 4133, 21.viii.1980, c. 6.5 km SW of Walkers Flat ferry crossing (AD); (Towitta): Kraehenbuehl 184, 31.vii.1960, river Marne Gorge (AD): South - East Mallee Heathlands (Billiatt): Carrick 3306 - 3309, 14.xi.1972, Billiatt National Park (AD); (Pinnaroo): J.M. Black s.n., 12.x.1981, Pinnaroo (AD 96909064); (Karoonda): J.M. Black s.n., 10.x.1910, Lameroo (AD 96909004); (Moorlands): Williams 1039, 2.x.1970, between Malinong & Coomandook (AD); (The Big Desert): Sharrad 1095, 29.viii.1961, 30 miles from Pinnaroo (AD); (Cannawigara): Wilson 2089, 29.viii.1961, c. 65 km N of Bordertown (AD); (Bordertown): Hunt 234, 15.x.1961, c. 5 km NNE of Bordertown (AD); (Loydella): Conn 1040, 28.ix.1980, Braendler's scrub (AD); (Wood Hill): Cleland s.n., 12.x.1938, Chauncey's Line (AD 966031506); Northern Calcarenite Ridges and Plains (Catana): J.M. Black 25, -.ix.1917, Yumali (AD); (Karoonda): E. & A. Ashby 228, -.xi.1940, between Keith and Bordertown (AD): Murray Lakes (Goolwa): Carrick 2980, 11.xi.1971, Finnis (AD). - Mt Lofty Block: Peninsula Uplands (Sandergrove): Cleland s.n., 26.xi.1966, Sandergrove scrub (AD 97315375): Kangaroo Island (Mt Marsden): Crocker s.n., 13.xi.1954, Bay of Shoals (ADW 4341); (Amberley): Conn 1057 - 1063, 11.xi.1980, North Coast road, c. 1 km WNW of Playford Highway (AD, MEL); (MacGillivray): Ising s.n., 12.x.1922, MacGillivray (AD 97249325); (Gantheaume): Crisp 394, 28.viii.1971, western boundary of Dudley National Park (AD). - [Yorke Peninsula] Gulf Plains (Workurna): B. Copley 1408, 29.viii.1967, c. 16 km N of Bute (AD). - [Eyre Peninsula] Northern Myall Plains (Middleback Range): Lothian & Francis 706, 18.ix.1960, Middleback ranges (AD); Central Mallee Plains and Dunes (Midgee): Orchard 2943, 29.xii.1970, c. 10 km S of Iron Duke (AD); (Cleve): Lothian s.n., 29.vi.1959, 15 km N of Cowell (AD 96322062).

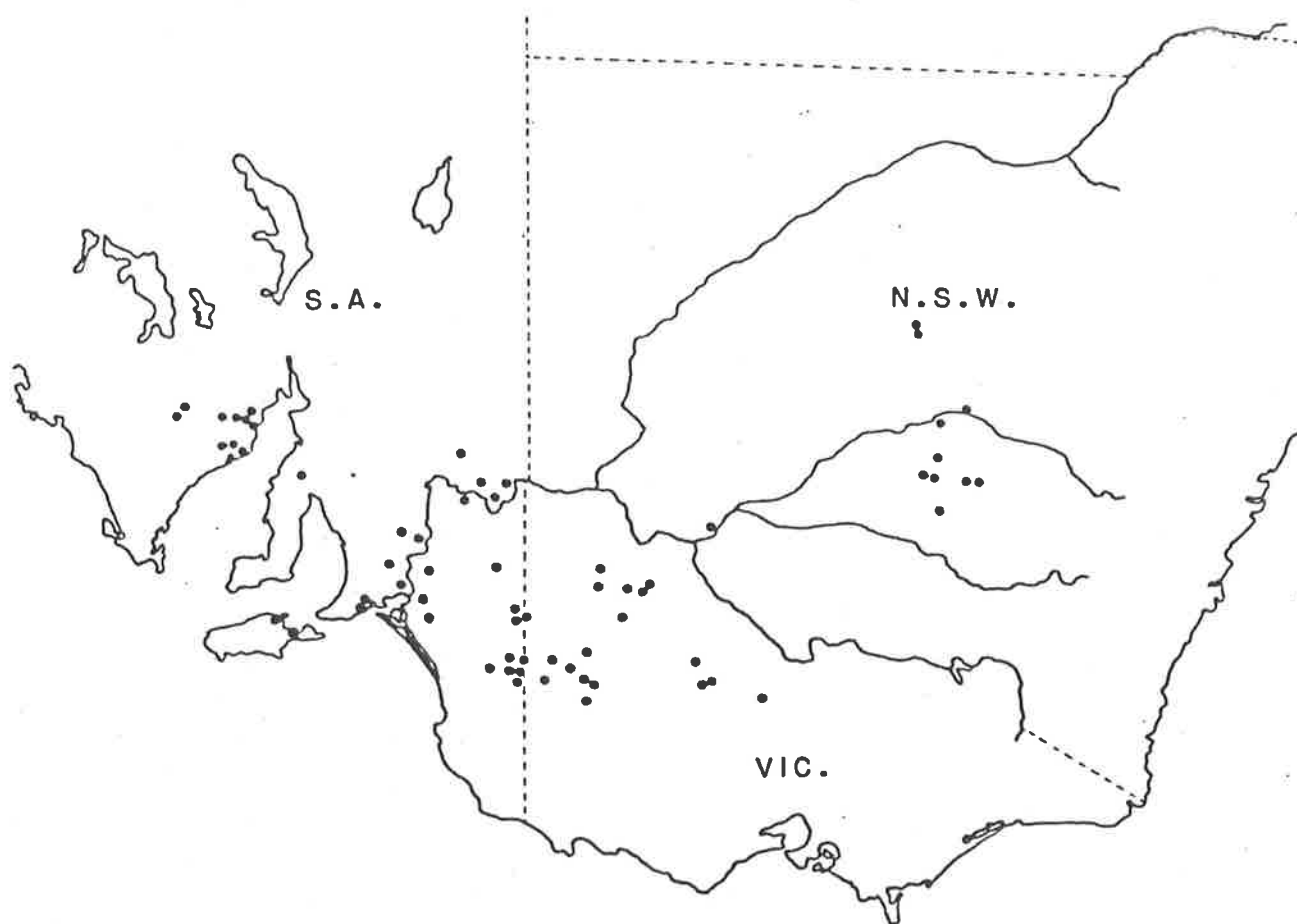


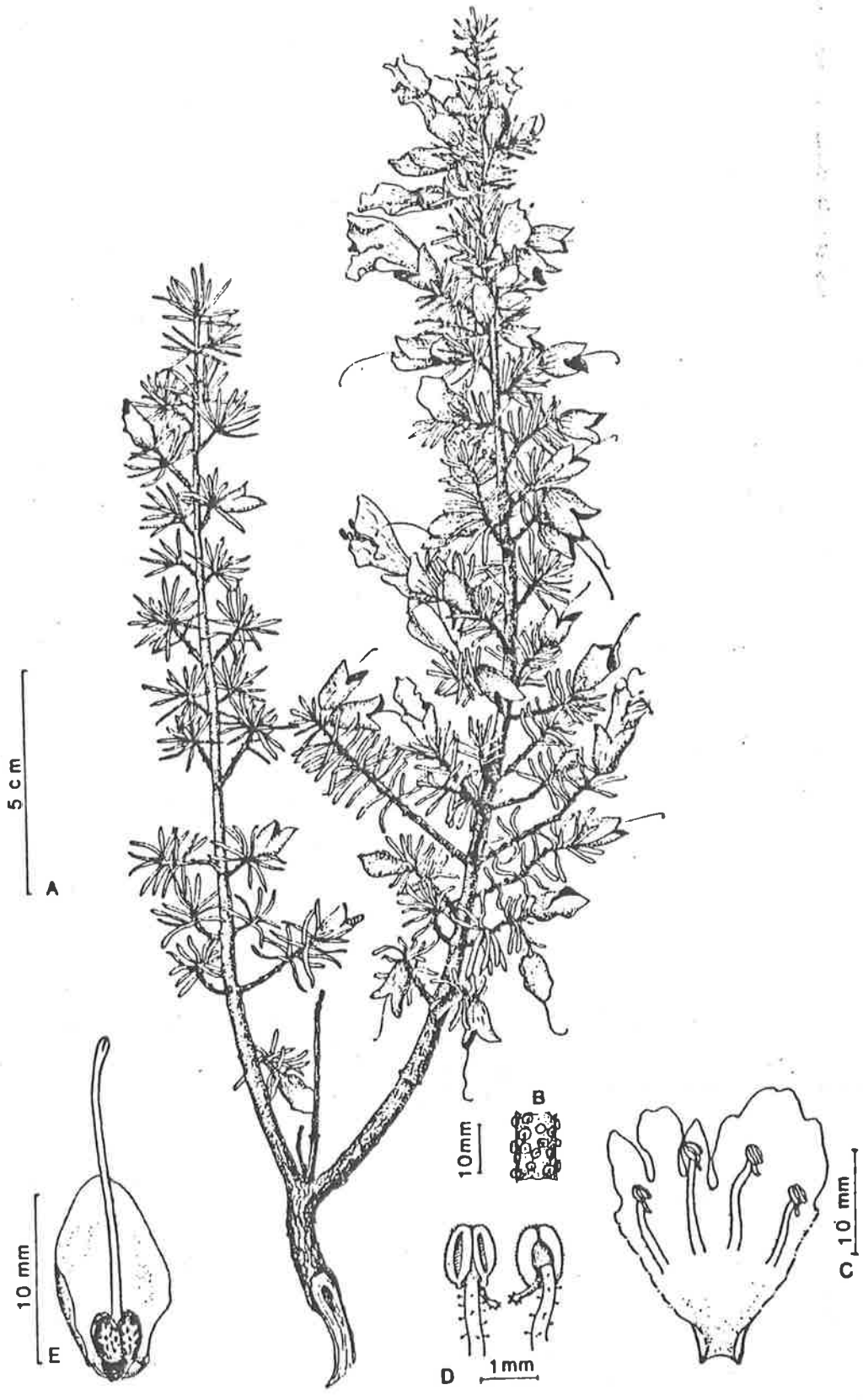
Fig. 63. Distribution map of *Prostanthera aspalathoides*.

6. *Prostanthera florifera* Conn, sp. nov. - Figs 64 & 65

Species nova sectionis Klanderiae. Fructices parvi 0.3 - 1 m. alti. Rami et ramuli plus minusve teretes, dense tomentosi. Folia sparsim tomentosa usque glabrescentia, glandifera; petiolus absens; lamina lineari-lanceolata usque lineari-oblonga, 4 - 10 mm. longa, 0.6 - 1 mm. lata, basi attenuata, margine integro, apice obtuso usque rotundato. Pedicellus florum 3 - 4 mm. longus, sparsim tomentosus usque glabrescens, bracteolis usque ad 1 mm. e basi calycis affixis. Calyx 7 - 12 mm. longus, glaber, glandifer; tubus 5 - 7 mm. longus; lobi late deltoidei, 2 - 5 mm. longi, circa 5 - 7 mm. lati, margine fimbriato, apice rotundato. Corolla 20 - 26 mm. longa, rubra; tubus 12 - 15 mm. longus, extra in partibus distalibus sparsim tomentosus, intra glaber; lobi extra sparsim tomentosi, intra glabrescentes, abaxialis-mediano oblongo-obovato, circa 5 mm. longo, 2.5 - 3 mm. lato, margine plus minusve irregulari, apice obtuso usque rotundato, emarginato, sinu 0.5 mm. longo, lateralibus ovatis usque oblongi-ovatis, 3 - 4 mm. longis, 2 - 3 mm. latis, margine fimbriato, apice obtuso, adaxiali-mediano plus minusve ovato-deltoideo, 7 - 9 mm. longo, 8 - 9 mm. lato, margine plus minusve irregulari, fimbriato, apice obtuso. Stamina circa 11 mm. e basi corollae affixa; filamenta 8 - 10 mm. longi; antherae 1.5 - 2 mm. longae, appendice 1 - 2.5 mm. longa. Pistillum 25 - 28 mm. longum; ovarium circa 1 mm. longum; stylus circa 25 mm. longus; lobis stigmatibus circa 1 mm. longis. Fructus coccis 2 - 2.5 mm. longis.

Holotypus: Conn 675, 18.ix.1979, Miccollo Hill, Gawler Ranges (Western Pastoral), northern Eyre Peninsula, South Australia (AD; iso in BRI, CANB, K, MEL, NSW, PERTH).

Fig. 64. *Prostanthera florifera*. - A. twig and flowers;
B. glands on branch; C. open corolla; D. stamens - ventral
and dorsal views; E. open calyx to show mericarps, style
and stigma (all Whibley 387).



Small, + densely branched shrub, 0.3 - 1 m high. Branches + terete, densely tomentose, at least some leaves clustered on short branches. Leaves very sparsely hairy, especially medially and basally, to glabrescent, glandular; petiole absent; lamina linear-oblong to linear-oblong, 4 - 10 x 0.6 - 1 mm, + flat, thick, base attenuate, margin entire, apex obtuse to rounded, venation not visible. Pedicel 3 - 4 mm long, sparsely hairy to glabrescent; prophylls inserted up to 1 mm from base of calyx, hence overlapping basal part of calyx, oblong-linear to linear-lanceolate, c. 3 mm long, slightly concave, both surfaces glabrous, rarely with an occasional hair, margin sparsely fimbriate, apex obtuse. Calyx 7 - 12 mm long, glabrous, glandular; tube 5 - 7 mm long, 5 - 6 mm wide at mouth; lobes broadly triangular 2 - 5 mm long, c. 5 - 7 mm wide at base, margin fimbriate, apex rounded. Corolla 20 - 26 mm long; outer surface of tube pink-red; inner surface pale pink with tinge of white or with pink-red blotches, inner surface of lobes white with dark brown blotches or sometimes yellow-brown with pink spots; tube 12 - 15 mm long, outer surface sparsely tomentose distally, inner surface glabrous, with a few scattered glandular hairs distally; lobes sparsely tomentose on outer surface, glabrescent on inner surface, abaxial median lobe oblong-obovate, c. 5 mm long, 2.5 - 3 mm wide at base, margin + irregular, apex obtuse to rounded, emarginate, sinus 0.5 mm long, lateral lobes ovate to oblong-ovate, 3 - 4 mm long, 2 - 3 mm wide at base, margin fimbriate, apex obtuse, adaxial median lobe-pair + ovate-deltoid, 7 - 9 mm long, 8 - 9 mm wide at base, margin + irregular, fimbriate, at least basally and distally, apex obtuse. Stamens inserted c. 11 mm above base of corolla; filaments, 8 - 10 mm long, glandular with stalked glands and broad triangular glandular trichomes; anthers, 1.5 - 2 mm long, lobes with a minute basal acumen, one side of connective basally extended to form a long slender appendage, appendage 1 - 2.5 mm long, with a few

triangular trichomes on appendage. Pistil 25 - 28 mm long; ovary c. 1 mm long, diameter c. 1 mm at base, lobes small, c. 0.5 mm long; style c. 25 mm long; stigma lobes c. 1 mm long. Mericarps 2 - 2.5 mm long, distally 1 - 1.5 mm extended beyond base of style.

Distribution: South Australia - Western Pastoral (Gawler and Uno Ranges).

Ecology: Occurs on rocky precambrian porphyric (Twidale 1968) rhyodacite derived soils with scattered shrubs of *Acacia sowdenii*, *A. montana*, *Eremophila interstans*, *Melaleuca uncinata*, spinifex (*Triodia*), *Isopogon*, *Calytrix* and ephemerals, especially on hills in rocky places towards ridge tops. Usually occurring at higher altitudes than *Dodonaea viscosa* (Sapindaceae). Soils silt.

Note: This species is closely related to *P. aspalathoides* (refer pp. 194 - 201) and the relationship between these two is graphically presented in the canonical variate scattergrams and the nearest neighbour phenogram (Figs 7 - 9 [*P. florifera* = D, *P. aspalathoides* = 1 - 4]). *P. florifera* is most readily distinguished from the latter species by having longer anther appendages [1 - 2.5 mm long cf. up to 0.3(-0.5) mm in *P. aspalathoides*]. Several other characters are larger and/or longer in *P. florifera* than *P. aspalathoides*. For example, *P. florifera* tends to have longer pedicels (3 - 4 mm cf. 2 - 3 mm), longer calyces (7 - 12 mm cf. 5 - 7 mm [longer calyx tube: 5 - 7 mm cf. 3 - 4 mm]), longer corolla (20 - 26 mm cf. 10 - 20 mm [longer corolla tube: 12 - 15 mm cf. 8 - 11 mm]), longer abaxial median corolla lobe (c. 5 mm cf. 2 - 3 mm), and longer style (c. 25 mm cf. 15 - 20 mm). The collections from the Uno Range tend to have smaller leaves (more typical of *P. aspalathoides*) than those from

the Gawler Ranges.

Selected specimens examined: (c. 50 collections)

SOUTH AUSTRALIA. - [northern Eyre Peninsula] Western Pastoral (Uno Range):
Donner 8088, 8095, 23.ix.1981, eastern side of main range, southern end
 (AD); Whibley 7864, 7870, 24.ix.1981, north-western end of range (AD);
Whibley 7962, 25.ix.1981, c. 10 km E of Uno Station (AD): (Gawler):
Barker 3583, 24.ix.1978, c. 18 km NNE of Peterby Tank (AD); Conn 675,
 18.ix.1979, Miccollo Hill (AD); Conn 679, 19.ix.1979, Mt Yardea (AD, MEL);
Conn 680, 19.ix.1979, Kododo Hill (AD, MEL); B. Copley 2093; 2095, 31.viii.
 1968, c. 25 km E of Yardea homestead (AD); B. Copley 2739, 1.viii.1969,
 c. 9 km W of Yardea homestead (AD); Crawford s.n., 16.x.1968, NE of Buckle-
 boo (AD, ADW); Donner 3227, 28.ix.1969, Mt Ive (AD); Gardiner s.n., 5.viii.
 1969, Spring Hill, c. 90 km NW of Kimba (AD); Haegi 732, 17.x.1975, c. 25 km
 NNW of Kimba (AD); Haegi 756, 17.x.1975, c. 50 km NNW of Minnipa (AD);
Haegi 831, 21.x.1975, Mt Yardea (AD); Lay 687, 29.ix.1972, c. 5 km S of
 Yarna homestead (AD); Newman s.n., -.ix.1962, Hiltaba Station (AD); Orchard
980, 26.vii.1968, Mt Partridge (AD); Orchard 1789, 1796, 27.x.1968, c.
 40 km N of Minnipa (AD); Orchard 2168, 15.viii.1969, SW part of Yandinga
 Gorge (AD); Orchard 2230, 26.ix.1969, Yandinga Gorge (AD); Orchard 2329,
 28.ix.1969, c. 5 km E of intersection of Yardea, Nonning and Kingoonya roads
 (AD); Reichstein 1581, 28.viii.1973, Nonning Station (AD); Rohrlach 422,
 Peterlumbo (AD); Rohrlach 497, 3.ix.1959, E corner of sect. 31, Pinkawill-
 inie (AD); Rohrlach 785, 27.viii.1960, c. 2 km NW of Pile Pudla Dam (AD);
Rohrlach 907, 17.ix.1961, Thurlga Station (AD); Spooner 2524, 8.ix.1972,
 Kododo Hill (AD); Symon 8040, 8045B, 1.x.1972, near summit of Mt Nott (ADW);
Symon 8173, 5.x.1972, 2 km NW of Dancing Bob Dam (ADW); Symon 8175, 5.x.
 1972, Waltinga Dam (ADW); Symon 8189, 6.x.1972, 6 km NW of Pine Lodge (ADW);

Whibley 387, 15.x.1958, 6 km NW of Minnipa-Yardea road (AD); Whibley 797, 27.ix.1960, c. 25 km NNW of Kimba, along Hundred line Gunyarie and Cortlinye (AD); Wilson 279, 7.x.1958, 13 km SW of Buckleboo railway Siding (AD); Wilson 555, 17.x.1958, Mt Yardea (AD).

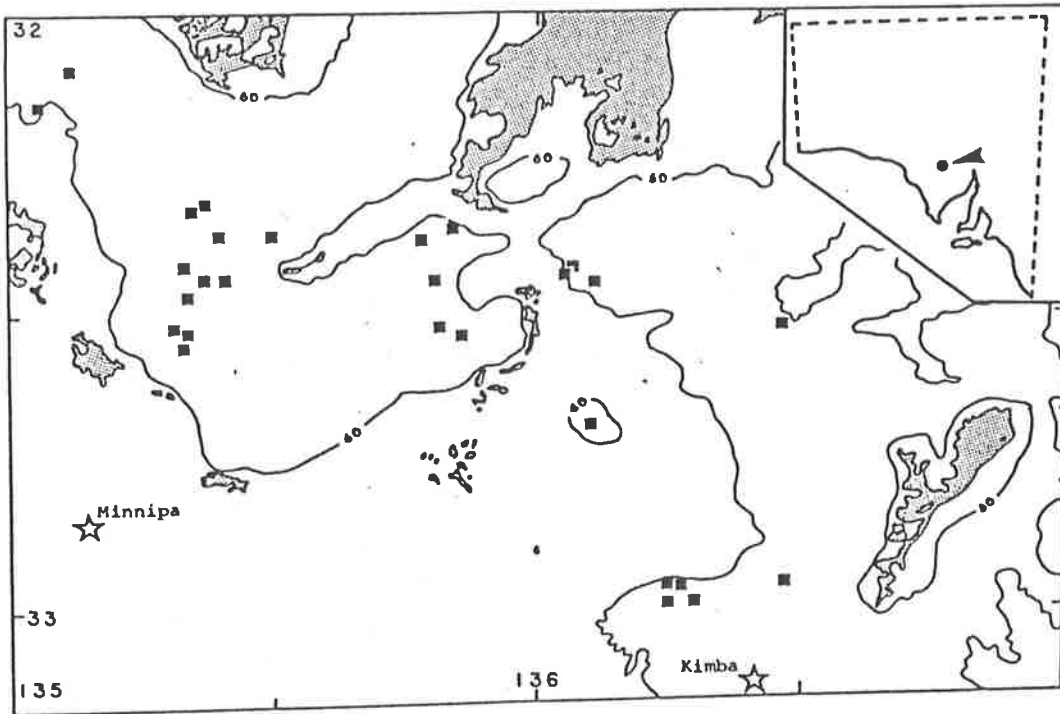


Fig. 65. Distribution map of *Prostanthera florifera*. Stippled areas = lakes or salt pans; contour line (m). Locality of Gawler ranges and Uno range given in insert map.

7. *Prostanthera pedicellata* Conn, sp. nov. Figs 66 & 68

Species nova sectionis Klanderiae. Frutices parvi 0.3 - 1 mm. alti. Rami et ramuli teretes usque subteretes, saepe internodiis iuvenibus leviter sulcatis, glabris, dense glandiferis. Folia glabra, glandifera; petiolus absens aut si praesens tum minus quam 1 mm. longus; lamina angusta, lanceolata, oblonga usque oblanceolata, (3-)5 - 8(-11) mm. longa, 1.5 - 2.5 mm. lata, basi attenuata, margine integro parum incrassato, saepe parum recurvo, apice obtuso, saepe recurvo. Pedicellus florum 8 - 15 mm. longus, ad basim glaber, alibi sparsim tomentosus, bracteolis 1 - 5 mm. e basi calycis affixis. Calyx 6 - 8 mm. longus, extra tomentosus; tubus 4 - 5 mm. longus, intra glaber; lobi plus minusve deltoidei, 2.5 - 3 mm. longi, 3 - 4 mm. lati, intra glabri praeter ad marginem sparsim tomentosi, raro glabri, apice obtuso usque subacuto. Corolla 20 - 25 mm. longa, rubra, extra in partibus distalibus tomentosa, saepe dense; tubus 11 - 15 mm. longus; lobi intra sparsim pilosi, abaxiali-mediano plus minusve ovato, 3 - 5 mm. longo, circa 2 mm. lato, recto usque recurvo, margine integro, apice subacuto usque obtuso, lateralibus plus minusve deltoidesis usque ovatis, circa 2 mm. longis, margine integro, adaxiali-mediano late oblongo usque subovato, interdum late ovato, 5 - 6 mm. longo, (6-)8 - 10 mm. lato, margine integro, apice rotundato, plerumque emarginato, sinu usque ad 1 mm. longo. Stamina circa 10 mm. e basi corolla affixa; filamenta 10 - 12 mm. longi; antherae 2 - 2.5 mm. longae, appendice absens aut si praesens tum minus quam 0.1 mm. longa. Pistillum 25 - 30 mm. longum; ovarium circa 0.6 mm. longum; stylud 20 - 25 mm. longus; lobis stigmati usque ad 0.5 mm. longis. Fructus coccis 2 - 3 mm. longis

Holotypus: Ashby 2993, 3.ix.1969, Pindar, northern Avon (South-West), Western Australia (AD; iso in PERTH).

Fig. 66. *Prostanthera pedicellata*. - Twig and flowers

(Ashby 1993).



Small slightly spreading shrub, 0.3 - 1 m high. Branches terete to subterete, often with faint grooving on distal internodes (from one leaf axis to next node alternatively), glabrous, densely glandular, glands \pm hemispherical, touching. Leaves arranged along branches, not clustered, glabrous, glandular, (2-)17 - 87 glands/mm²; petiole absent or if present then less than 1 mm long, usually indistinct, grooved on adaxial surface; lamina narrow, lanceolate, oblong to oblanceolate, (3-)5 - 8(-11) x 1.5 - 2.5 mm [lamina length to width ratio 4.6 - 6.7, distance of maximum width from base of lamina to total length 0.26 - 0.67], base attenuate, margin entire, slightly thickened, often slightly recurved, apex obtuse, often recurved; venation indistinct, occasionally base of midrib faintly raised on lower surface. Pedicel 8 - 15 mm long, glabrous basally, sparsely hairy distally, especially above point of insertion of prophylls; prophylls inserted 1 - 5 mm from distal end of pedicel, usually not overlapping basal part of calyx, oblong-linear to linear-oblanceolate, 2.5 - 4 x 0.5 mm, slightly concave, glabrous or sparsely hairy, apex obtuse, often slightly recurved. Calyx 6 - 8 mm long, green with maroon tinge distally; outer surface hairy, hairs 0.4 - 0.6 mm long, white; tube 4 - 5 mm long, inner surface glabrous; lobes \pm triangular, 2.5 - 3 mm long, 3 - 4 mm wide at base, inner surface glabrous basally, sparsely hairy towards margin (rarely glabrous), apex obtuse to subacute. Corolla 20 - 25 mm long, red; outer surface distally hairy, often densely so; tube 11 - 15 mm long; lobes sparsely pilose on inner surface, abaxial median lobe \pm ovate, 3 - 5 mm long, c. 2 mm wide at base, straight to recurved, margin entire, apex subacute to obtuse; lateral lobes \pm triangular to ovate, c. 2 mm long, margin entire; adaxial median lobe-pair broad-oblong to subobovate, sometimes broad-ovate, 5 - 6 mm long, (6-)8 - 10 mm wide at base, margin entire, apex rounded, usually emarginate, sinus up to 1 mm long. Stamens inserted c. 10 mm above base of corolla; filaments 10 - 12 mm long, with a few

scattered, minute \pm triangular glandular trichomes; anthers 2 - 2.5 mm long, base of lobes with small acumen, acumen 0.1 - 0.3 mm long, appendage absent or if present then less than 0.1 mm long. Pistil 25 - 30 mm long; ovary c. 0.6(-1) mm long, diameter at base c. 1 mm, lobes small, c. 0.3 mm long; style 20 - 28 mm long; stigma lobes up to 0.5 mm long. Mericarps 2 - 3 mm long, distally c. 1 mm extended beyond base of style; seed unknown.

Distribution: Western Australia (South - West: Avon).

Ecology: Growing in *Acacia*, *Eremophila*, *Melaleuca* shrubland. Soil a yellow-brown loam with ironstone gravel often present on the surface.

Note: This new species has its closest affinities with *P. semiteres*. In particular, there is a superficial similarity between *P. pedicellata* and *P. semiteres* ssp. *intricata*. Both have relatively long pedicels and both lack staminal appendages. *P. pedicellata* differs by having calyces with hairy outer surfaces (glabrous in *P. semiteres*) and broader usually longer leaves (leaves 1.5 - 2.5 mm wide in *P. pedicellata*, 0.5 - 1.2 mm wide in *P. semiteres*).

Short 994 (AD), which was collected towards the end of a relatively dry season (15.xi.1979), has leaves similar to *P. semiteres* and so may represent an intermediate specimen between the two taxa. Ross 2734 & 2735 (MEL) have calyces which are glabrous on their inner surfaces and only have a few scattered hairs on their outer surfaces. In all other respects, these collections are identical with Ross 2732, 2733, 2736 & 2737 which are all from the same population.

This species appears to be very rare and the small population at

Pindar (Western Australia) is apparently rapidly decreasing in size as its habitat is cleared.

Specimens examined:

WESTERN AUSTRALIA. - South-West: northern Avon (Pindar): Ashby 2993, 3.ix.1969 (AD, PERTH); Ashby 5035, -.ix.1973 (AD); Ashby 5112, -.ix.1973 (AD); Maiden s.n., -.x.1909 (NSW 126722, NSW 126726); Oliver for Ashby 3931, -.viii.1971 (AD); Phillips 54467, 20.ix.1968 (AD); Ross 2732 - 2737, 1.ix.1982 (MEL); Short 994, 15.xi.1979 (AD).

8. *Prostanthera incurvata* Conn, sp. nov. - Figs 67 & 68

Species nova sectionis Klanderiae. Frutices parvi, 0.4 - 0.7 m. alti. Rami et ramuli plus minusve teretes, tomentosi, glandiferi. Folia glabra; petiolus absens aut si praesens tum minus quam 1 mm. longus; lamina complanata angusta, oblanceolata usque oblonga, 5 - 10.3 mm. longa, 0.8 - 1.2 mm. lata, saepe incurvata, basi attenuata, margine integro, apice obtuso usque rotundato. Pedicellus florum 0.8 - 1.8 mm. longus, glaber, dense glandifer, bracteolis ad basim calycis affixis. Calyx 6 - 8 mm. longus, extra glaber, intra ad basim glaber, alibi dense tomentosus; tubus 4 - 5 mm. longus; lobi late deltoidei, (1.5-)2 mm. longi, 3.5 - 4 mm. lati, margine integro, apice obtuso. Corolla 15 - 20 mm. longa, rosea usque rubra, interdum lutea, extra in partibus distalibus moderate usque dense tomentosa, intra glabra usque glabrata; tubus circa 10 mm. longus; lobus abaxiali-medianus plus minusve obovatus, 3 - 3.5 mm. longus, rectus usque recurvus, margine integro, apice obtuso, lateralibus oblongo-ovatis, 2 - 2.5 mm. longis, margine integro, apice obtuso usque rotundato, adaxiali-mediano plus minusve obovato, circa 3 mm. longo, recto, margine integro usque parum irregulari, apice obtuso, emarginato, sinu 1 - 1.5 mm. longo. Stamina 7 - 8 mm. e basi corollae affixa; filamenta 6 - 7 mm. longa; antherae 1.5 - 1.8 mm. longae, appendice absentis. Pistillum 20 - 23 mm. longum; ovarium 0.6 - 0.8 mm. longum; stylus 18 - 20 mm. longus; lobis stigmatis circa 1 mm. longis. Fructus coccis circa 2 mm. longis.

Holotypus: N. T. Burbidge 2664, 19.ix.1947, Pioneer rock, N of Lake Cowan, Western Australia (PERTH; iso in CANB).

Small shrub, 0.4 - 0.7 m high. Branches ± terete, hairy (rarely glabrous), hairs usually ± restricted to two opposite longitudinal grooves, 80 - 190(-270) hairs/mm², hairs 0.09 - 0.3 mm long, ± erect [base of hair to first bend 0.04 - 0.07; greatest distance hair from branch is 0.04 - 0.16 mm], white, moderately dense-glandular, 56 - 109 glands/mm², glands hemispherical. Leaves usually clustered on short lateral shoots, sometimes arranged along the branches, glabrous; petiole absent or if present then less than 1 mm long; lamina flattened, narrow-oblong to narrow-oblong, 5 - 10.3 x 0.8 - 1.2 mm [lamina length to width ratio 4.9 - 14; distance of maximum width to total lamina length 0.2 - 0.8], frequently incurved; base attenuate, margin entire, apex obtuse to rounded; venation indistinct, midrib region often slightly sunken on adaxial surface. Pedicel 0.8 - 1.5(-2) mm long, ± terete, light green, glabrous, densely glandular; prophylls inserted at base of calyx (rarely up to 0.3 mm from base of calyx), hence overlapping with base of calyx, ± lanceolate, 1.7 - 4.2(-4.7) x c. 0.6 mm [length to width ratio 3.4 - 7(-8.4)], glabrous, margin entire, apex obtuse to subacute. Calyx 6 - 8 mm long, green; outer surface glabrous, moderately to densely glandular, glands hemispherical, 40 - 133 glands/mm²; inner surface glabrous basally, densely hairy (indumentum tomentose to pubescent) in mouth and on lobes, (51-)100 - c. 400 hairs/mm², hairs weak, ± curled, entangled, usually less than 0.08 mm long, white; tube 4 - 5 mm long; lobes broadly triangular, (1.5-)2 mm long, 3.5 - 4 mm wide at base [calyx lobe to tube ratio 0.5 - 0.8], margin entire, apex obtuse. Corolla 15 - 20 mm long, pink to red, sometimes yellow, outer surface moderately to densely hairy distally (70 - 100 hairs/mm²), hairs 0.3 - 0.4 mm long, white; inner surface glabrous, sometimes with an occasional hair near margin; tube c. 10 mm long; abaxial median lobe ± obovate, 3 - 3.5 mm long, extended forward to recurved, margin entire, apex obtuse; lateral lobes oblong-ovate, 2 - 2.5 mm long, margin entire, apex obtuse to

rounded; adaxial median lobe-pair ± obovate, c. 3 mm long, extended forward, margin entire to slightly irregular, apex obtuse, emarginate, sinus 1 - 1.5 mm long. Stamens inserted 7 - 8 mm from base of corolla; filaments 6 - 7 mm long, glandular triangular trichomes present; anthers 1.5 - 1.8 mm long, base of lobes with minute acumen, acumen c. 0.1 mm long, appendage absent. Pistil 20 - 23 mm long; ovary 0.6 - 0.8 mm long, lobes small, c. 0.1 mm long; style 18 - 20 mm long; stigma lobes c. 1 mm long. Mericarps c. 2 mm long (possibly immature), distally extended c. 0.8 mm beyond base of style.

Distribution: Western Australia (Eremaean: Austin, Coolgardie).

Ecology: Only two collectors have made notes on the ecology of this species. At Mount Hunt it occurs on serpentinites (Bale 123), whereas at Lake Cowan it occurs in red sands (Broadbent 1054).

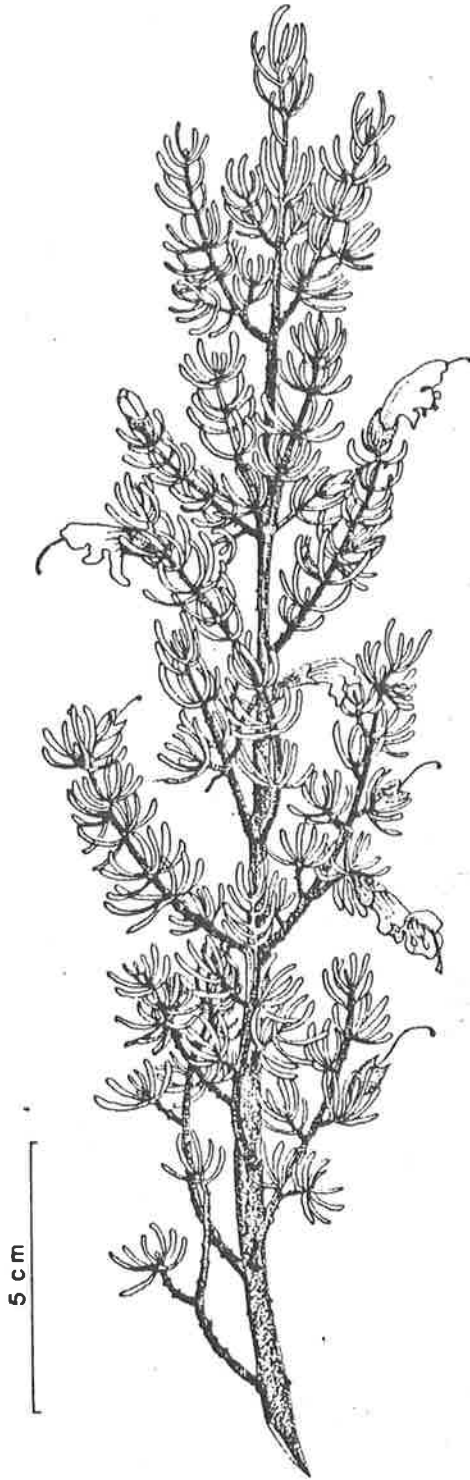
Note: This new species is closely related to *P. semiteres*. However, *P. incurvata* has a shorter pedicel [0.8 - 1.5(-2) mm cf. 3 - 15 mm in *P. semiteres*], smaller usually incurved leaves, a larger lamina length to width ratio, is more glandular and hairier than *P. semiteres*. However, Cronin s.n. (MEL 1512008) is glabrous. For further discussion on this species refer 'Numerical analysis of the *Prostanthera laricoides* complex' and 'Morphological variation in the *Prostanthera laricoides* complex'.

Specimens examined:

WESTERN AUSTRALIA. - Eremaean: Austin: Bale 123, -.x.1965, Mt Hunt, near Boulder (PERTH). - Coolgardie: Beard 3371, 26.v.1964, S of Coolgardie (KP); Blackall 979, -.x.1931, 25 miles N of Norseman (PERTH); Broadbent 1054,

Fig. 67. *Prostanthera incurvata*. - Twig and flowers

(Phillips CBG 23260).



23.vii.1953, Lake Cowan (NSW); N. Burbidge 2664, 19.ix.1947, Pioneer Rock, near Lake Cowan (CANB); Canning CBG 26146, 6.ix.1968, 22 miles from Coolgardie, towards Norseman (AD 96920342); Chinnock 3055, 15.ix.1976, Mt Monger (AD); Cronin s.n., anno 1893, between upper Blackwood River and Lake Lefroy (MEL 1512008); Helms s.n., -.vi.1898, Coolgardie (NSW 126727); Helms s.n., -.vii.1899, Coolgardie (K,PERTH); Kemsley s.n., -.v.1952, Kambalda (MEL 43820); Lidgey 5 & 7, 22.viii.1900, Hampton plains, near Coolgardie (K); Phillips CBG 20619, 11.ix.1962, c. 75 miles N of Norseman (AD 96915102); Phillips CBG 23260, 4.ix.1968, Spargoville (AD 96918133); Phillips CBG 23274, 4.ix.1968, ?Beacon Hill, Norseman (AD 96918148); Wilson 3112, 14.ix.1964, near Londonderry (AD).

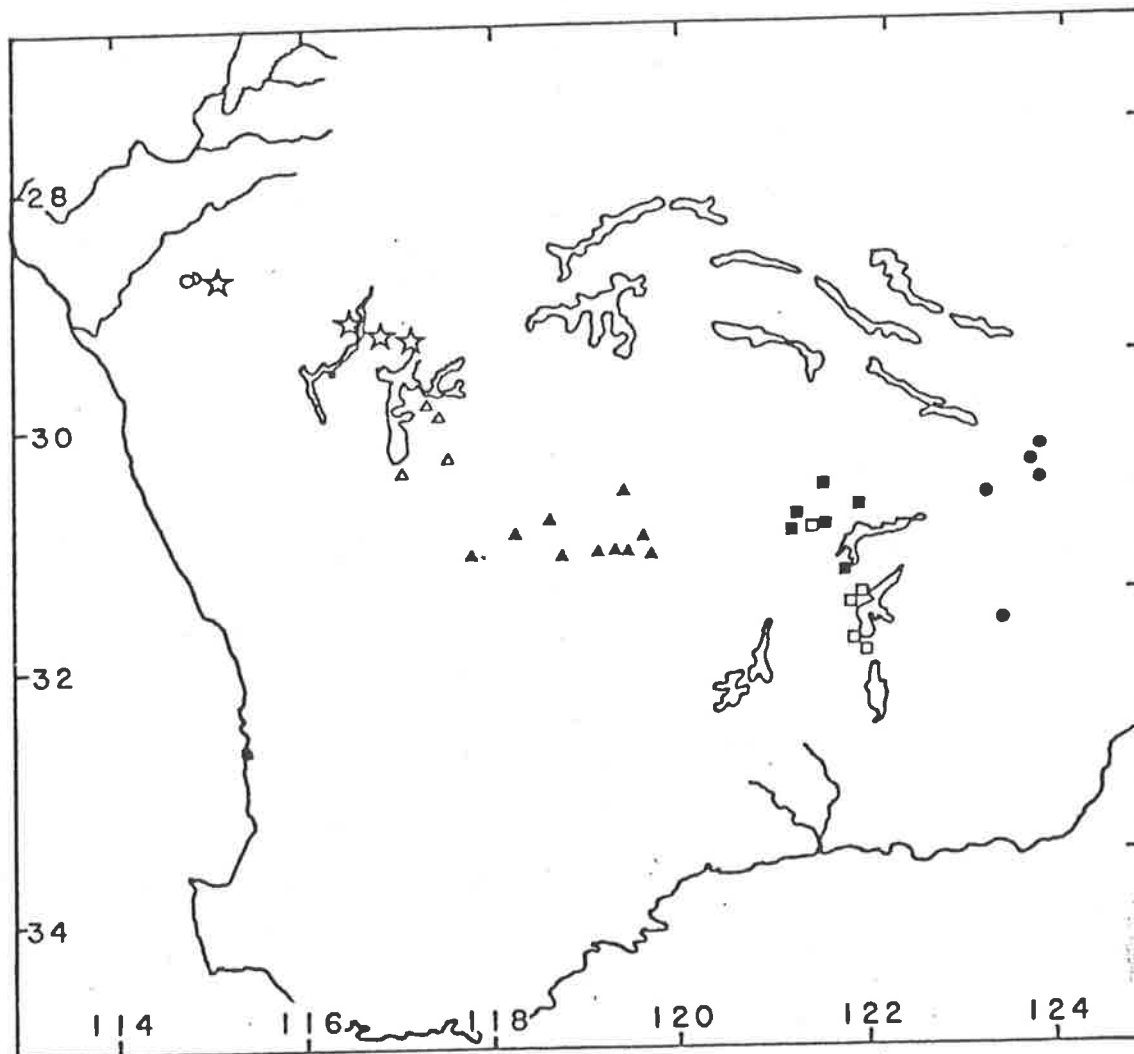


Fig. 68. Distribution map of the *Prostanthera laricoides* complex.

- *P. laricoides*; ■ *P. incurvata*; □ *P. incurvata* (hairy branches);
- ▲ *P. semiteres* ssp. *semiteres*; △ *P. semiteres* ssp. *intricata*;
- ☆ *P. patens*; ○ *P. pedicellata*.

9. *Prostanthera semiteres* Conn, sp. nov. - Figs 68 & 69

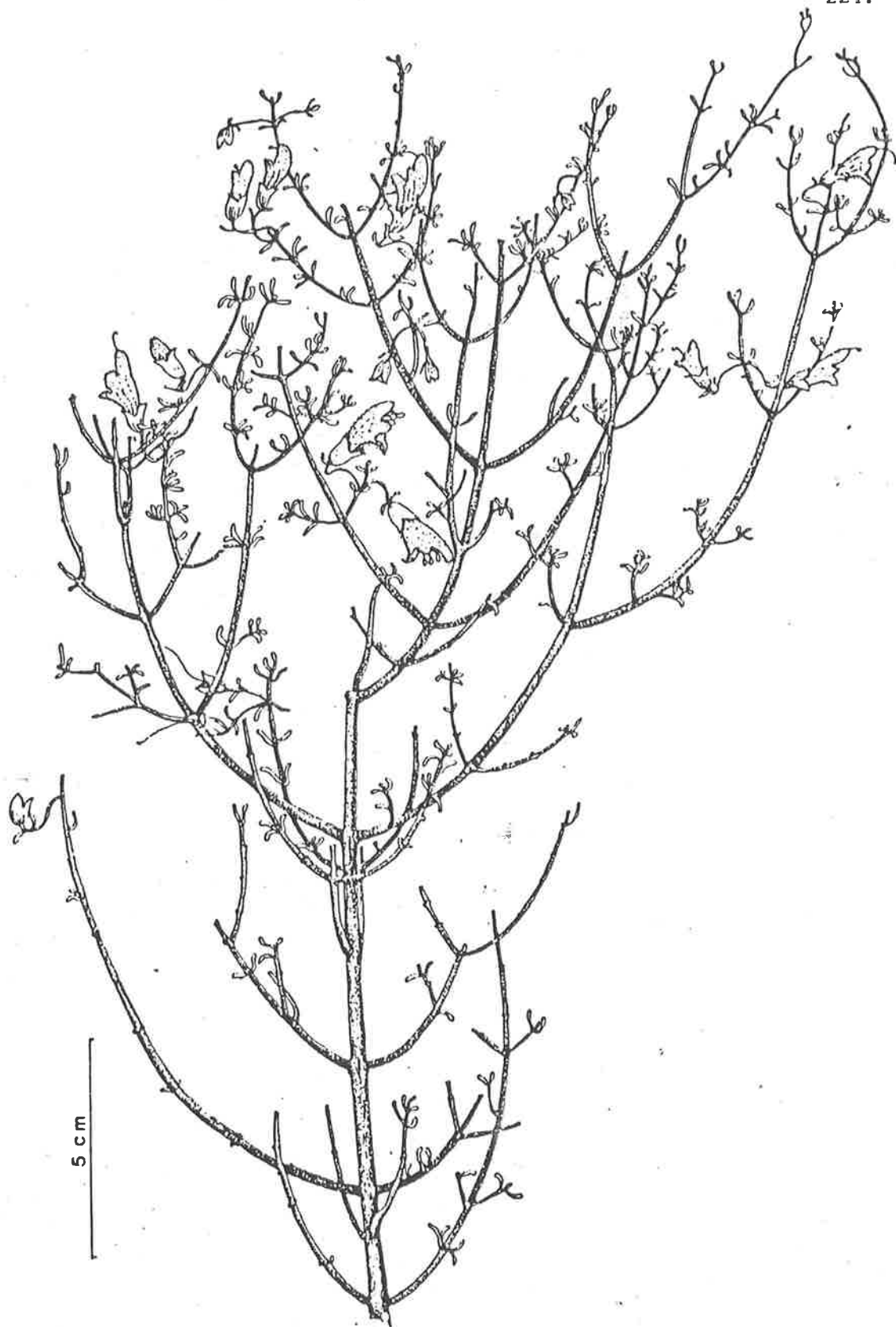
Species nova sectionis Klanderiae. Frutices parvi, usque ad 1.3 m. alti. Rami et ramuli plus minusve teretes, glabri. Folia glabra; petiolus absens aut si praesens tum usque ad 0.3 mm. longus; lamina angusta, obovata, oblanceolata usque oblonga, 2 - 12 mm. longa, 0.5 - 1.1 mm. lata, basi attenuata, margine integro, apice obtuso. Pedicellus florum 3 - 15 mm. longus, glaber, bracteolis usque ad 2.5 mm. e basi calycis affixis. Calyx 5 - 7.3 mm. longus, extra plerumque glaber; tubus 4 - 6 mm. longus, intra glaber vel tomentosus; lobi transverse angusto-deltoidei, 0.5 - 2 mm. longi, 3 - 5 mm. lati, intra in partibus distalibus tomentosi, margine integro, apice obtuso. Corolla 16 - 25 mm. longa, rubra vel rosea, extra in partibus distalibus tomentosus; tubus 6 - 14 mm. longus; lobus abaxiali-medianus plus minusve obovatus, oblongo - ovatus usque deltoideus, 2 - 3.5 mm. longus, recurvus usque reflexus, margine integro, apice obtuso usque rotundato, lateralibus oblongis, vel latis et ovatis usque deltoideis, 1 - 3 mm. longis, erectis usque recurvis, margine integro, apice subacuto usque obtuso, adaxiali-mediano lato, ovato usque obovato, 3 - 5 mm. longo, margine integro, apice obtuso, emarginato, sinu usque ad 1.5 mm. longo. Stamina 7.5 - 9 mm. e basi corollae affixa; filamenta 4 - 8 mm. longa; antherae 1.2 - 2 mm. longae, appendice absentis. Pistillum 22 - 27 mm. longum; ovarium 0.5 - 0.8 mm. longum; stylus 21 - 25 mm. longus; lobis stigmatis 0.1 - 0.7 mm. longis. Fructus coccis 2 - 3 mm. longis.

Holotypus: Chinnock 3132, 20.ix.1976, 2.9 km E of Campion, on Warralakin road, South-West botanical district, Western Australia (AD).

Small shrub, up to 1.3 m high. Branches + terete, glabrous.

Leaves arranged along main axes and branches, not clustered along short axes, glabrous; petiole absent or if present, then up to 0.3 mm long; lamina narrow, obovate, oblanceolate to oblong, 2 - 12 x 0.5 - 1.2 mm, base attenuate, margin entire, apex obtuse; venation indistinct, midrib usually slightly sunken on adaxial surface. Pedicel 3 - 15 mm long, glabrous; prophylls inserted up to 3 mm from base of calyx, narrow, oblong to oblanceolate, 1.5 - 3(-4.1) x 0.2 - 0.5 mm [length to width ratio 3.5 - 8.7], often incurved, becoming recurved to reflexed, glabrous, margin entire, apex obtuse. Calyx 5 - 7.3 mm long, outer surface usually glabrous, glandular; tube 4 - 6 mm long, inner surface glabrous or hairy distally; lobes transversely narrow-triangular, 0.5 - 2 mm long, 3 - 5 mm wide at base, glabrous at base, hairy distally, margin entire, apex obtuse. Corolla 16 - 25 mm long, red or pink; outer surface hairy distally, 35 - 48 hairs/mm²; tube 6 - 14 mm long, inner surface glabrous; abaxial median lobe + obovate, oblong-ovate to triangular, 2 - 3.5 mm long, recurved to reflexed, margin entire, apex obtuse to rounded; lateral lobes oblong, or ovate to triangular, 1 - 3 mm long, erect to recurved, margin entire, apex subacute to obtuse; adaxial median lobe-pair broad, ovate to obovate, 3 - 5 mm long, margin entire, apex obtuse, emarginate, sinus up to 1.5 mm long. Stamens inserted 7.5 - 9 mm from base of corolla; filaments 4 - 8 mm long; anthers 1.2 - 2 mm long, base of lobes with a minute acumen, acumen up to 0.2 mm long, appendage absent. Pistil 22 - 27 mm long; ovary 0.5 - 0.8 mm long, diameter up to 1.2 mm at base, lobes small, 0.1 - 0.2 mm long; style 21 - 25 mm long; stigma with lobes 0.1 - 0.7 mm long. Mericarps 2 - 3 mm long, distally 1 - 1.7 mm extended beyond base of style.

Fig. 69. *Prostanthera semiteres* ssp. *intricata*. - Twig and
flowers (Ashby 3585).



Distribution: Western Australia (Eremaean: Austin, Coolgardie; South-West: Avon).

Note: This species has its closest affinities with *P. pedicellata* (refer p. 212 for details). It is also closely related to *P. incurvata*. However, it is readily distinguishable from the latter species by its longer pedicels [3 - 15 mm long cf. 0.8 - 1.5(-2) mm in *P. incurvata*], usually larger leaves and smaller lamina length to width ratio. For further discussion of this species refer 'Numerical analysis of the *Prostanthera laricoides* complex' and 'Morphological variation in the *Prostanthera laricoides* complex'.

The north-western populations of *P. semiteres* (Fig. 68) have noticeably longer pedicels and smaller leaves than the more south-eastern ones. The former group is recognized as a distinct subspecies (*viz.* *P. semiteres* ssp. *intricata*). The key differences between the two subspecies are summarized in the 'Key to the subspecies of *P. semiteres*' (see below).

KEY TO SUBSPECIES OF *P. SEMITERES*

- 1a. Pedicel up to 5.5 mm long; prophylls inserted up to 1 mm from base of calyx; leaves (5.5-)9 - 11 mm long; calyx lobes to calyx tube ratio 0.14 - 0.43 ssp. *semiteres*
- 1b. Pedicel 7 - 15 mm long; prophylls inserted (1.5-)2 - 3 mm from base of calyx; leaves 2 - 6 mm long; calyx lobes to calyx tube ratio 0.3 - 0.56 ssp. *intricata*

ssp. *semiteres* - Fig. 68

Small shrubs, up to 1.3 m high. Lamina narrow, oblanceolate to

oblong, 8 - 12 x 0.7 - 1.1 mm [length to width ratio 8 - 17(-20); ratio of distance of maximum width from base to total lamina length (0.05-)0.4 - 0.8]. Pedicel 3 - 4(-5.5) mm long, green, often with purple tinge; prophylls inserted up to 1 mm from base of calyx. Calyx green or purple-green; outer surface glabrous, glandular, (17-)22.5 - 65(-83.3) glands/mm²; tube glabrous; lobes 0.5 - 1.5 mm long, c. 5 mm wide at base [calyx lobe to tube ratio 0.14 - 0.43], inner surface hairy distally, (3-)41 - 147 (-253) hairs/mm². Corolla tube 6 - 12 mm long. Staminal filaments 4 - 6.5 mm long. Stigma lobes 0.1 - 0.4 mm long.

Distribution: refer Fig. 68.

Ecology: Occurs amongst granitic rocks (Beard 4744, 5944), in granitic sandy loams (Chinnock 3132), on schiotose hills (Gardner 2797), and in red clay-loams (George 2670).

Specimens examined:

WESTERN AUSTRALIA. - Eremaean: Coolgardie: Anon. s.n., 21.x.1895, Southern Cross (PERTH); Beard 4744, 17.vii.1967, 20 miles W of Bullfinch (A, PERTH); Beard 5091, -.viii.1967, Warralackin-Bullfinch area (KP); Beard 5944, 19.vii.1970, 6 miles N of Weowanie Rock (KP, PERTH); Blackall 896, 13.xi.1931, by salt lake at Southern Cross (PERTH); Demarz 5261, 10.x.1974, 4 miles N of 242 mile peg on Great Eastern Highway (KP, PERTH); Gardner 2797, -.ix.1931, Lake Polaris, Southern Cross (K, PERTH); George 2670, 20.viii.1961, c. 28 miles E of Southern Cross (PERTH); Newbey 2538, 5.ix.1966, Koolyanobbing Range (PERTH); P. Wilson 3508, 23.ix.1964, 9 km E of Southern Cross (AD); P. Wilson 3515, 23.ix.1964, 16 km E of Southern Cross (AD). - South-West: Avon: Chinnock 3132, 20.ix.1976, 2.9 km E of

Campion (AD); Gardner 2060, 6.x.1927, Noongar (K, PERTH).

ssp. *intricata* Conn, ssp. nov. Figs 68 & 69

Frutices parvi, circa 0.3 m. alti. Lamina angusta, oblonga usque obovata, 2 - 6 mm. longa. Pedicellus florum 7 - 15 mm. longus, bracteolis 2 - 2.5 mm. e basi calycis affixis. Lobis calycis 1 - 2 mm. longi, circa 3 mm. lati. Tubus corollae 9 - 14 mm. longus. Filamenta staminum 6 - 8 mm. longa. Lobi stigmatis 0.5 - 0.7 mm. longi.

Holotypus: Ashby 3585, 7.ix.1970, Beacon, South-West botanical district, Western Australia (PERTH; iso in AD).

Small shrub, c. 0.3 m high. Lamina narrow, oblong to obovate, 2 - 6 x 0.5 - 1 mm [length to width ratio 5 - 9.6; ratio of distance of maximum width from base to total lamina length up to 0.66]. Pedicel 7 - 15 mm long, maroon or dark green with tinge of red; prophylls inserted (1.5-)2 - 3 mm from base of calyx. Calyx green, often dark green and/or with tinge of maroon distally; outer surface glabrous or rarely with an occasional hair distally, 0(-3) hairs/mm², moderately glandular 20 - 46 glands/mm²; inner surface moderately to densely hairy, 34 - 106 hairs/mm²; lobes 1 - 2 mm long, c. 3 mm wide at base [calyx lobe to tube ratio 0.3 - 0.56]. Corolla tube 9 - 14 mm long. Staminal filaments 6 - 8 mm long. Stigma lobes 0.5 - 0.7 mm long.

Distribution: refer Fig. 68.

Ecology: not known.

Note: This subspecies is easily distinguished from ssp. *semiteres* by its long pedicels [7 - 15 mm long cf. up to 5.5 mm in ssp. *semiteres*] and short leaves [2 - 6 mm long cf. (5.5-)9 - 11 mm in ssp. *semiteres*]. It is superficially similar to *P. pedicellata*, however the usually glabrous outer surface of the calyx, the densely hairy inner surface of the calyx, and the small calyx lobe to tube ratio readily distinguish this subspecies from the latter species.

Specimens examined:

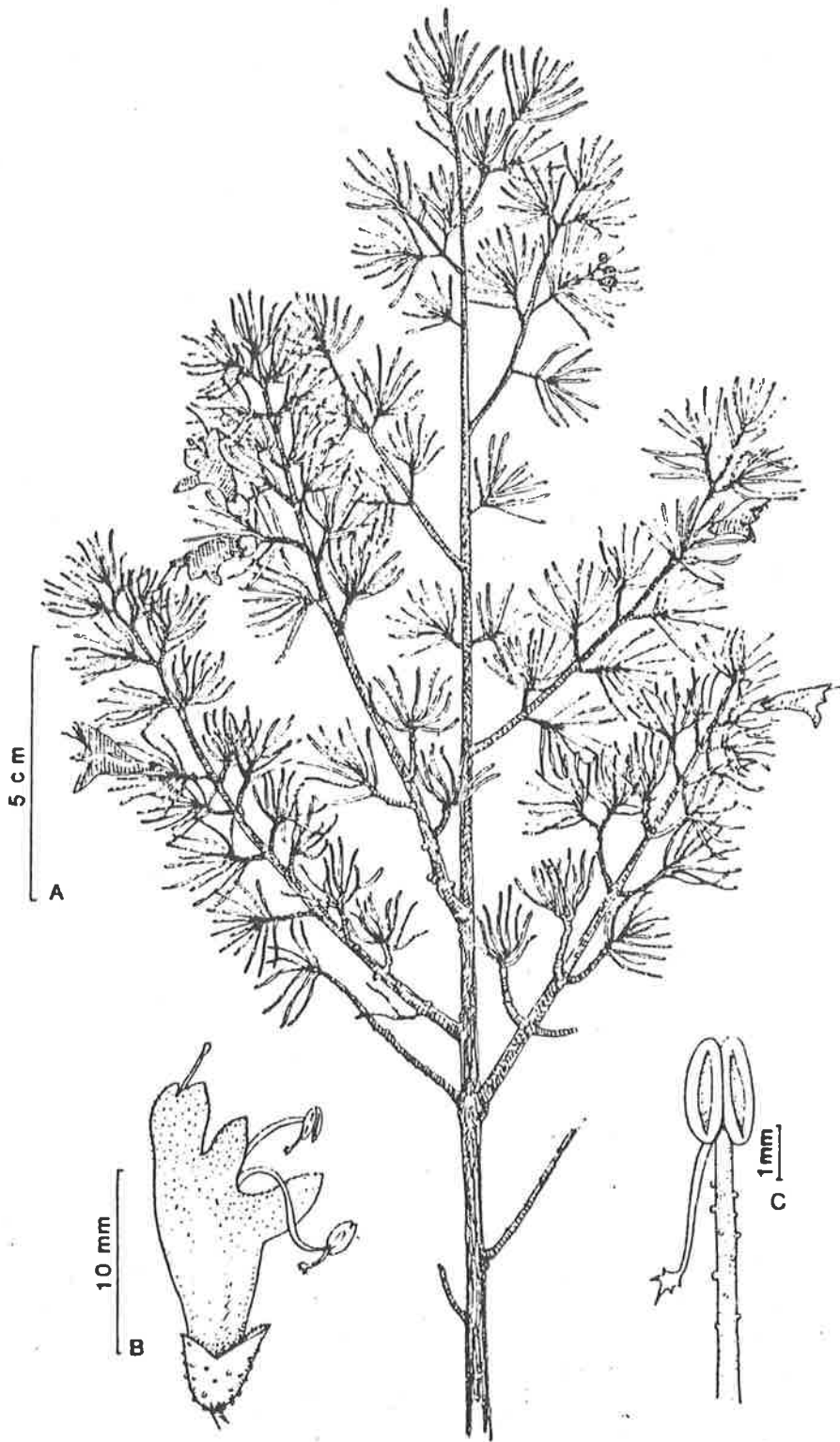
WESTERN AUSTRALIA. - Eremaean: Austin: Weber 5188, 18.x.1975, c. 15 km E of Mouroubra Homestead (AD). - Coolgardie: Mt Churchman: Blackall 3432, 3452, 13.x.1937 (PERTH); Rosier 309, 17.ix.1963 (PERTH); Young s.n., s. dat. (MEL 43397). - South-West: Avon: Ashby 3585, 7.ix.1970, Beacon (AD, PERTH); Harvey & Rosier 251, -.x.1960, Mollerin (PERTH).

10. *Prostanthera laricoides* Conn, sp. nov. - Figs 68 & 70

Species nova sectionis Klanderiae. Frutices parvi, 1 - 1.2 m. alti. Rami et ramuli plus minusve teretes, partim dense tomentosi, pilis 0.1 - 0.2 mm. longis, dense glandiferi, internodiis iuvenibus parum complanatis. Folia glabra, dense glandifera; petiolus absens; lamina teretes, interdum pagina adaxiali leviter sulcata, (5-)10 - 18(-20) mm. longae, 0.4 - 0.7 mm. latae, basi attenuata, margine integro, apice obtuso usque rotundato. Pedicellus florum circa 1 mm. longus, dense tomentosus, bracteolis ad basim calycis affixis, mox caducis. Calyx 4 - 6 mm. longus, extra parum tomentosus, pilis usque ad 0.1 mm. longis, intra ad basim glaber, alibi parum tomentosus, pilis (0.07 -)0.1 - 0.2 mm. longis; tubus 3 - 4.5 mm. longus; lobi late deltoidei, 1.5 - 2 mm. longi, circa 3 mm. lati, margine integro, fimbriato, apice rotundato. Corolla 14 - 18 mm. longa, rubra, extra in partibus distalibus sparsim tomentosa; tubus 10 - 12 mm. longus; lobus abaxiali-medianus plus minusve oblongo-ovatus, 3 - 4 mm. longus, 1.5 - 2.3 mm. latus, margine integro, fimbriato, apice obtuso usque rotundato, lateralibus plus minusve late oblongis usque ovatis, circa 2 mm. longis, circa 2 mm. latis, margine integro, fimbriato, apice rotundato, adaxiali-mediano late ovato, circa 4 mm. longo, circa 5 mm. lato, margine integro usque parum irregulari, apice plus minusve obtuso, emarginato, sinu usque ad 1 mm. longo. Stamina 8.5 - 10 mm. e basi corollae affixis; filamenta 4 - 5 mm. longa; antherae 1.5 - 1.8 mm. longae, appendice (1-)1.5 - 2 mm. longa. Pistillum 20 - 22 mm. longum; ovarium 0.5 - 1 mm. longum; stylus circa 20 mm. longus; lobis stigmatibus circa 0.5 mm. longis. Fructus coccis 2 - 2.5 mm. longis.

Holotypus: Boswell F66, anno 1967, Cundeelee, Helms botanical district, Western Australia (PERTH).

Fig. 70. *Prostanthera laricoides*. - A. Twig and flowers;
B. flower; C. stamen - ventral view (all Boswell F66).



Small shrub, 1 - 1.2 m high. Branches + terete, slightly flattened distally, densely tomentose from within each axil to the next upper node, hairs 0.1 - 0.2 mm long, densely glandular. Leaves clustered (leaf bearing branches 1 - 4 mm long), glabrous, densely glandular; petiole absent; lamina terete, sometimes faintly grooved along adaxial surface, (5-)10 - 18(-20) x 0.4 - 0.7 mm, base attenuate, margin entire, apex obtuse to rounded; venation not visible. Pedicel c. 1 mm long, densely hairy, hairs less than 0.1 mm long, glandular; prophylls inserted near distal end of pedicel and so, overlapping basal part of calyx, soon caduous, + linear, c. 0.5 mm long, concave, glabrous, margin fimbriate, hairs up to 0.2 mm long, apex obtuse. Calyx 4 - 6 mm long; outer surface sparsely minute-hairy, 45 - 159 hairs/mm², hairs up to 0.05 - 0.1 mm long; inner surface glabrous on basal 2 - 2.5 mm, sparsely hairy distally, 68 - 220 hairs/mm², hairs (0.7-)0.1 - 0.2 mm long; tube 3 - 4.5 mm long; lobes broadly triangular, 1.5 - 2 mm long, c. 3 mm wide at base, margin entire, fimbriate, hairs c. 0.1 mm long, apex rounded. Corolla 14 - 18 mm long, red; outer surface sparsely tomentose distally, hairs up to 0.2 mm long; tube 10 - 12 mm long; lobes glabrous on inner surface; abaxial median lobe + oblong-ovate, 3 - 4 x 1.5 - 2.3 mm, margin entire, fimbriate, apex obtuse to rounded; lateral lobes + broad-oblong to ovate, c. 2 mm long, c. 2 mm wide at base, margin entire, fimbriate, apex rounded; adaxial median lobe-pair broad-ovate, c. 4 mm long, c. 5 mm wide at base, margin entire to slightly irregular, fimbriate, apex + obtuse, emarginate, sinus up to 1 mm long, up to 2 mm wide distally. Stamens inserted 8.5 - 10 mm above base of corolla; filaments 4 - 5 mm long, with slightly raised glands; anthers 1.5 - 8 mm long, one side of connective extended to form a basal appendage, appendage (1-)1.5 - 2 mm long, broad-triangular trichomes present at distal end of

appendage, trichomes c. 0.1 mm long. Pistil 20 - 22 mm long; ovary 0.5 - 1 mm long, diameter c. 0.5 mm at base, lobes small; style c. 20 mm long; stigma lobes c. 0.5 mm long. Mericarps 2 - 2.5 mm long, distally 1 mm extended beyond base of style.

Distribution: Western Australia (Eremaean: Helms, Coolgardie).

Ecology: All that is known about the ecology of this species is that it occurs 'on sandy soil among rocks' (Royce 5371).

Note: The affinities of *P. laricoides* are uncertain. It is similar to *P. patens* in a number of features (e.g. long anther appendages, prophylls inserted near distal end of pedicel, high density of hairs on outer surface of calyx [refer 'Morphological variation in the *Prostanthera laricoides* complex']), but it has long narrow leaves, and indumentum in two rows on opposite 'sides' of branches (similar to *P. incurvata*). Furthermore, the density of glands on all parts, and the lamina length to width ratio are similar to those of *P. incurvata*. Overall, *P. laricoides* is probably most closely related to *P. incurvata*. For further discussion of this species refer 'Numerical analysis of the *Prostanthera laricoides* complex' and 'Morphological variation in the *Prostanthera laricoides* complex'.

Specimens examined:

WESTERN AUSTRALIA. - Helms: Boswell F66, anno 1967, Cundeelee (PERTH); Butler s.n., 26.i.1959, Queen Victoria Springs (PERTH); Carrick 3995A, 8 miles S of Cundeelee, 10 miles N of Zanthus (AD): Coolgardie: Main s.n., 9.xii.1953, Newman Rock (PERTH); Royce 5371, 29.i.1956, W of Coonana, on Trans. Line (PERTH); Royce 5472, 1.x.1956, 15 miles N of Zanthus, towards Cundeelee (PERTH).

11. *Prostanthera ringens* Benth. - Figs 71 & 72

Prostanthera ringens Benth., in Mitch., J. trop. Austral. (1848)363; in DC., Prodr. 12(1848)700; Fl. austral. 5(1870)106; Woolls, Pl. New S. Wales (1885)83; Tate, Trans Roy. Soc. S. Austral. (1889)111; Handb. fl. extratrop. S. Austral. (1890)151, 252; C. Moore, Handb. fl. New S. Wales (1893)352; Briq., in Engl. & Prantl, Nat. Pflanzenfam. 4: 3a(1895)220; F.M. Bailey, Queensl. fl. 4(1901)1203, 1204; Dixon, Pl. New S. Wales (1906) 232; F.M. Bailey, Compr. cat. Queensl. pl. (1913)392; Althofer, Cradle of Incense (1978)92, 99, 129. - S y n t y p e s: [Drysdale (Mitchell 1848, p. 359) for] T.L. Mitchell 577 & 570 [two numbers but only one specimen], 1 & 16.ix.1846, 'Camp 29. Subtropical New Holland' ['on the Maranoa' [river], Bentham (1870)], Queensland (K n.v.; NSW 126717). [Refer Notes]

P. leichhardtii Benth., Fl. austral. 5(1870)106; Briq., in Engl. & Prantl, Nat. Pflanzenfam. 4: 3a(1895)220; F.M. Bailey, Queensl. fl. 4(1901) 1203; Compr. cat. Queensl. pl. (1913)392; Althofer, Cradle of Incense (1978) 31, 124, 125-129. - S y n t y p e s: Leichhart s.n., -.viii-ix.-, 'The Sandstone Ranges of Bottletree Creek, lat. 26°30' ', Queensland (K n.v., MEL 43332).

P. lepidota C.T. White, Proc. Roy. Soc. Queensl. 4(1944)74; Althofer, Cradle of Incense (1978)99, 124, 127. - S y n t y p e s: C.T. White 12404, 13.xi.1943, Enniskillen, Mitchell District, Queensland (A, AD, BRI n.v., CANB, K n.v., MO, NY, UC).

Bushy shrub up to 2 m high, diameter 1 - 1.5 m. Branches quadrangular, with two pairs of lateral ridges, sparsely to moderately hairy between the ridges from within the leaf axis to the next node, nodes hairy, hairs c. 0.1 mm long, densely glandular, glands hemispherical. Leaves glabrous or with a few scattered hairs basally; petiole absent or if present then up to

2(-3) mm long; lamina oblong, ovate to obovate, often narrow, 6 - 15 x (1-)2 - 6 mm, + flat, base + cuneate, margin entire, apex obtuse, often slightly emarginate when lamina ovate or obovate; venation not visible, occasionally faint, midrib slightly raised on lower surface, slightly sunken on upper surface, or indistinct. Pedicel 1 - 3.5 mm long, hairy, hairs 0.06 - 0.1 mm long; prophylls inserted near base of pedicel, hence not, or just overlapping base of calyx, broad-oblong, 0.6 - c. 1 x c. 0.5 mm, concave, abaxial surface shortly pubescent, adaxial surface glabrous, margin fimbriate, apex obtuse. Calyx 6 - 8 mm long (usually at least 10 mm in fruit); outer surface glabrous; inner surface with a few scattered glandular hairs; margin, and occasionally lobes, minutely fimbriate, especially in bud; tube c. 5 mm long; lobes broad-deltoid, c. 2 mm long, c. 3 mm wide at base, margin entire, apex + rounded. Corolla 14 - 23 mm long, pale blue-light green (olivaceous), light green - yellow or yellow; tube c. 10 mm long, diameter at mouth c. 5 mm, outer surface glabrous basally, at least on that portion enclosed by the calyx, distally sparsely hairy; lobes hairy on outer surface, inner surface glabrous; abaxial median lobe + ovate to obovate, (3-)4 - 5 mm long, c. 4 mm wide, margin entire, slightly irregular, apex obtuse to rounded; lateral lobes ovate-oblong, 2 - 3 mm long, c. 2 mm wide at base, margin irregular, apex obtuse; adaxial median lobe-pair + ovate, 4 - 9 mm long, 4 - 6 mm wide at base, margin entire to irregular, fimbriate, apex obtuse, sometimes emarginate, sinus up to c. 1 mm long. Stamens inserted c. 4 mm from base of corolla; filaments c. 6 mm long, glabrous with a few glandular trichomes; anthers 1.5 - 2 mm long, base of lobes obtuse, often with a short broad acumen, acumen c. 0.1 mm long, appendage absent. Pistil 20 - 25 mm long; ovary 1 - 1.5 mm long, diameter c. 1 mm at base,

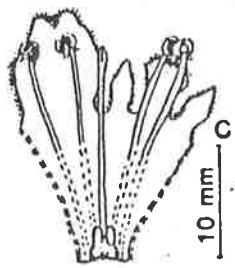
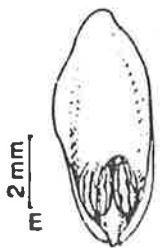
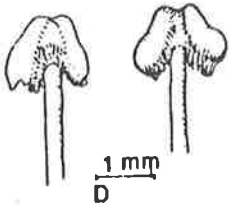
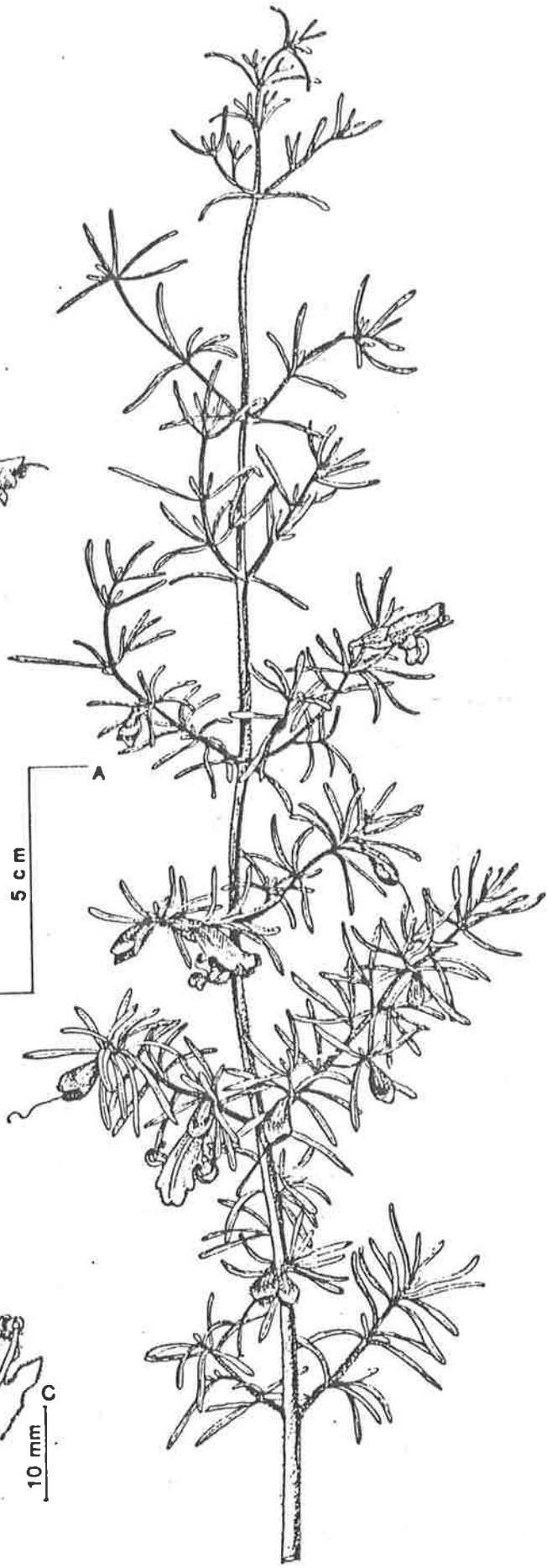
lobes small, c. 0.1 mm long; style c. 18 mm long; stigma lobes c. 1 mm long. Mericarps 2 - 2.5 mm long, distally extended c. 1 mm beyond base of style.

Distribution: Queensland (?Wide Bay or Moreton, Darling Downs, Maranoa, Mitchell), New South Wales (North Western Slopes, Central Western Slopes, North Western Plains, North Far Western Plains).

Ecology: Occurs in rocky sandstone ridges with *Prostanthera striatiflora*, *Eriostemon difformis* and *Eucalyptus morrisii* (at Cobar - Andrews s.n., -.xi.1910), in rocky crevices in tall shrublands with *Acacia doratoxylon* and *Eucalyptus viridis* (near Cobar - Crisp 4289), on stony hills with upturned shales and slates (Mt Nurri - Burbidge 6610), in red-brown gravelly sand with *Codonocarpus cotinifolius* and *Casuarina cristata* (Yuleba - Johnson 647), in stands of *Eucalyptus viridis* dominated Mallee communities (Goonoo forest - Willis & Althofer s.n.), and in mixed open forests on shallow hard grey soil (Glenmorgan - Blake 21268). Although rare, this species is often locally common. Altitudes 500 - c. 600 m.

Notes: The type material of *P. ringens* was collected by Drysdale from near 'Camp 29' (Mitchell 1848, map 4) while Mitchell was exploring north and north-west of this base camp. Whether the collections were made from near the Maranoa river or from the adjacent ranges is not clear (Mitchell 1848, p. 361). Although it appears that two collections were made on separate days, only one specimen is present on the NSW sheet. According to J. Carrick (*in adnot.*) a part of Mitchell 577 & 570 was sent to NSW in April 1915 (presumably NSW 126717). Whether the K or NSW material individually represent Mitchell 570 or 577 is not known. Since I have not examined the K material, lectotypification is delayed.

Fig. 71 . *Prostanthera ringens*. - A. twig and flowers
(Althofer s.n., cultivated material, Burrendong Arboretum);
B. twig and flowers (N. Burbidge 6610); C. open corolla;
D. stamens - ventral and dorsal views; E. part of calyx
removed to reveal mericarps (C - D all Althofer s.n.).



This species is characterized by the more or less flat leaves, the insertion of the prophylls near the base of the pedicel, and by the usually green to blue-green corolla (which is unusual in the prostantheras of Queensland and New South Wales). The affinities of this species are not clear.

There are two more or less distinct forms (*viz.* a broad-leafed group and a narrow-leafed group - Figs 71B & 71A, respectively).

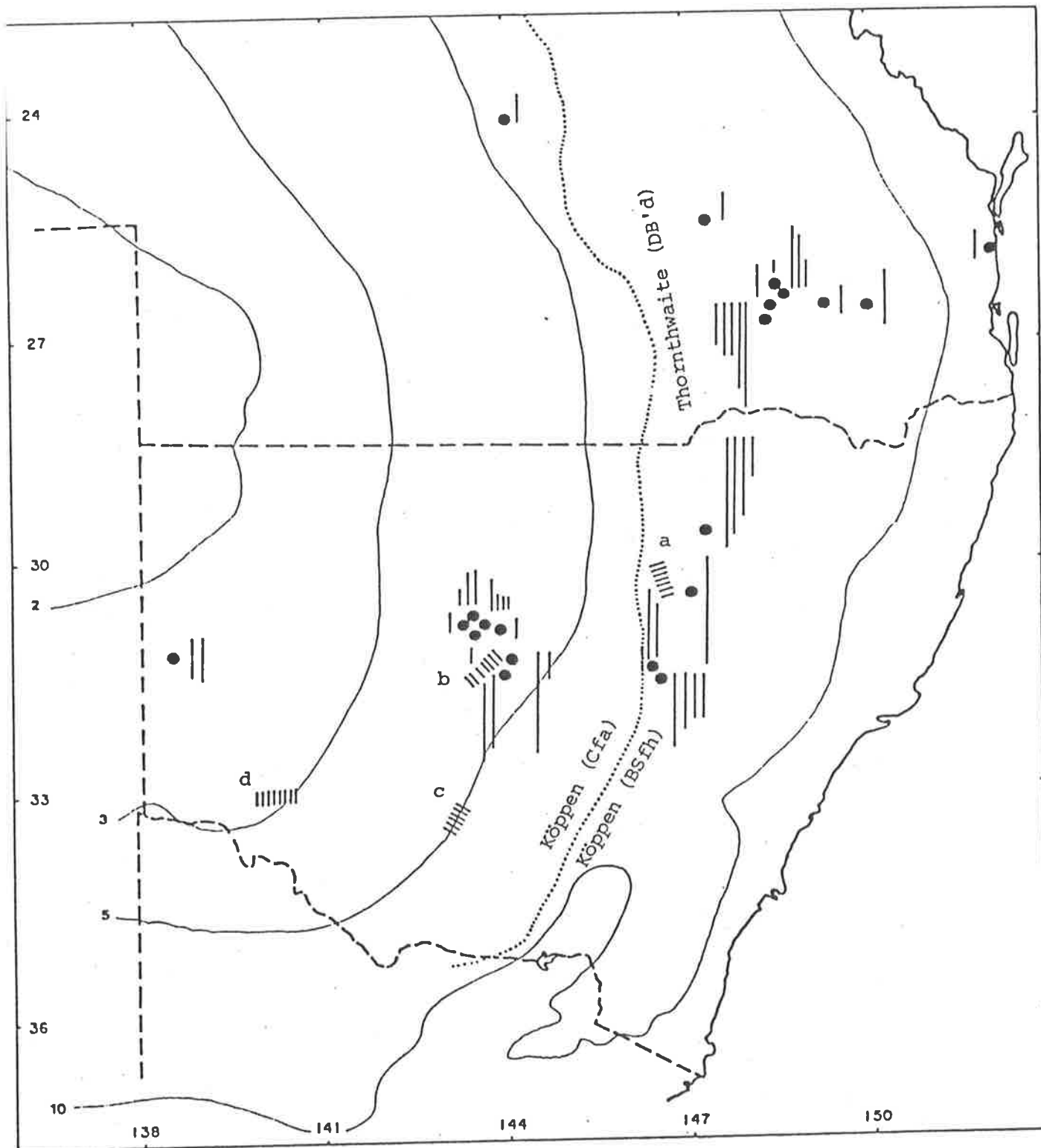
KEY TO THE GROUPS OF *P. RINGENS*

- 1a. Leaf length to width ratio (1.5-)3 - 5(-7.5);
 lamina width (1.5-)3 - 4(-6) mm Broad-leafed group
- 1b. Leaf length to width ratio (7.5-)8 - 15;
 lamina width 0.9 - 1.5(-2) mm Narrow-leafed group

The New South Wales populations of the broad-leafed group are mostly confined to the 'semi-arid' (BSfh) region (Köppen 1936) (= warm semi-arid [DB'd] region, Thornthwaite, 1933), refer figure 72. The narrow-leafed group is mostly confined to the 'Subhumid' (Cfa) region (Köppen 1936). Using Gentilli's Annual Phytohydroxeric Index (Gentilli, 1972) as a measure of the bioclimatic environment, the broad-leafed plants occur in the 'semi-arid' to 'arid' regions, with phytohydroxeric indices between 2 and 5 (refer, Fig. 72). This is equivalent to the Arid Moisture region of Gentilli (1972). Narrow-leafed plants occur in the 'subhumid' bioclimatic region, with phytohydroxeric indices equal to 5 and up to 10. This is equivalent to the SemiArid Moisture region (Gentilli 1972). These annual phytohydroxeric values appear to reflect climatic zones which largely control the biomass of the vegetation. Gentilli regards the threshold value 5 as the average limit between 'subhumid' and 'semi-arid' climates. The former normally supports an open woodland, whereas the latter supports a scrub or grass formation. The threshold value 3 is the average limit between 'semi-arid' and 'arid' climates. In New South Wales, there

Fig. 72 . Distribution map of *Prostanthera ringens*.

Histograms are of lamina length to lamina width ratios (LLW). a, b, c, & d = areas of steep climatic gradients in the frequency of arid years. Gentilli's phytohydroxeric indices, Köppen's Arid/Semi-arid, and Thornthwaite's Warm semi-arid boundary (dotted line) are superimposed onto map.



is a close correspondence between these phytohydroxeric values, Moisture regions and the type of community in which each group of plants occur. However, in the Darling Downs area of Queensland, there are a number of broad-leafed plants occurring with the narrow-leafed form (Fig. 72). The reasons for the mixture of forms in this region is not immediately obvious. However, the Darling Downs are climatically marginal, such that the transition from 'humid' to 'semi-arid' may be quite sudden and sweeping alternations are possible (Gentilli 1972).

The most consistently semi-arid areas are in the Tambo-Enniskillen (e.g. White 12404) and Maranoa-Balonne (e.g. Mitchell 577 & 570) areas.

There are a number of areas of New South Wales which have steep climatic gradients in frequency of arid years. Steep climatic gradients occur between Baradine and Coonamble (Fig. 72 -a) and between Nymagee and Cobar (Fig. 72 -b) (other steep climatic gradients are marked on Fig. 72, c - d). In other parts of the State, there is a more gradual increase in aridity to the west and north-west. These steep gradients (particularly, Fig. 72 -b) may explain the relatively sharp disjunction between the Cobar and Nymagee populations, and in general, they may act as part of the climatic boundary between these two groups.

A number of plants have been cultivated (e.g. at Burrendong Arboretum, Canberra Botanic Gardens and Adelaide Botanic Gardens) and these have retained their phenotypic distinctness. Therefore, it seems likely that the two groups are also genetically distinct. Since most specimens have been cultivated from cuttings taken from the original population (only Althofer s.n., 23.i.1944 cultivated from seed), we do not know the extent of the variability within each population. Detailed population studies are necessary to evaluate the ecotypic distinctness of these two groups.

Selected specimens examined: (55 collections)

QUEENSLAND: Darling Downs: C. White 13056, 4.x.1946, Kogan (CANB); Everist s.n., -.x.1969, ENE of Dalby, on road to Kogan (NSW 128469).

NEW SOUTH WALES: North Western Slopes: G. Althofer s.n., -.ix.1968, Pilliga Forest, Narrabri (AD). - Central Western Slopes: Willis & Althofer s.n., 9.x.1969, Mendooran road, in western portion of Goonoo Forest (AD 97609140, MEL 43326). - North Western Plains: G. Cunningham 719, 11.vii.1973, 'The Peak', Cobar (AD). - North Far Western Plains: Kaspiew 67, 3.x.-, Broken Hill (S).

12. *Prostanthera grylloana* F. v. Muell. - Figs 73 & 74

Prostanthera grylloana F. v. Muell., *Fragm.* 10(1876)17; Briq., in *Engl. & Prantl, Nat. Pflanzenfam.* 4: 3a(1895)220; Diels & Pritz, *Bot. Jahrb.* 35(1904)526, t. 59; G.A. Gardner, *Enum. pl. austral. occid.* (1931)114; Blackall & Grieve, *W. Austral. wildfl.* 3(1965) 594; J.S. Beard, *Descr. cat. W. Austral. pl. (s. dat. [Oct. 1965])*94; Althofer, *Cradle of Incense* (1978) 78, 80, 82. - H o l o t y p e: Young s.n., 10 - 15.x.1875, near Ularing, Western Australia (MEL 41915).

Small erect shrub, 0.3 - 1.5 m high. Branches subterete to quad-angular, densely short-pilose from one leaf axis to next nodal region alternatively. Leaves both clustered on short branches and arranged along main axis and branches, glabrous, glandular; petiole up to c. 1 mm long, often indistinct from lamina, deeply grooved on adaxial surface; lamina + spathulate 3 - 5(-10) x 2(-3) mm, recurved, coriaceous, adaxial surface deeply grooved such that both sides almost touching each other, base decurrent almost to base of petiole, margin entire, very slightly undulate, apex + rounded; venation not visible. Pedicel 1 - 1.5(-2) mm long, shortly tomentose; prophylls inserted 0.5 - 0.8 mm from distal end of pedicel, usually just overlapping with basal part of calyx, linear-oblong, c. 1 x 0.1 mm, soon falling off, the slightly enlarged basal part remaining (which is c. 0.2 mm long and 0.2 mm wide), minutely tomentose basally, apex subacute. Calyx 4 - 6 mm long; outer surface sparsely tomentose throughout, hairs c. 0.1 mm long; tube 4 - 4.5 mm long, inner surface glabrous; lobes + triangular, c. 2 mm long, 3 - 4 mm wide at base, inner surface densely, minute - pilose, hairs up to c. 0.1 mm long, margin entire, apex obtuse. Corolla (12-)15 - 20 mm long, red, outer surface distally sparsely tomentose; tube 10 - 14 mm

long, inner surface glabrous; lobes glabrous basally on inner surface, sparsely tomentose distally especially near apex and margin, abaxial median lobe + triangular, c. 5 mm long, 2 - 3 mm wide at base, margin + entire to slightly irregular, apex obtuse to subacute; lateral lobes + triangular, c. 2.5 mm long, c. 2.5 mm wide at base, + erect, margin entire, fimbriate, apex obtuse to subacute; adaxial median lobe-pair broadly oblong-ovate, 3.5 - 4 mm long, c. 4 mm wide at base, margin entire, apex rounded, emarginate, sinus up to 1 mm long. Stamens inserted c. 13 mm above base of corolla; filaments 4 - 5 mm long; anthers 1 - 1.5 mm long, base of lobes with small acumen, acumen up to 0.3 mm long, connective extended on one side to form a basal appendage, appendage 2 - 2.5 mm long, with a few + triangular trichomes. Pistil 20 - 24 mm long, ovary c. 0.3 mm long, style 19 - 21 mm long; stigma lobes up to 0.5 mm long. Mericarps c. 2 mm long, distally c. 0.5 mm extended beyond base of style; seed unknown.

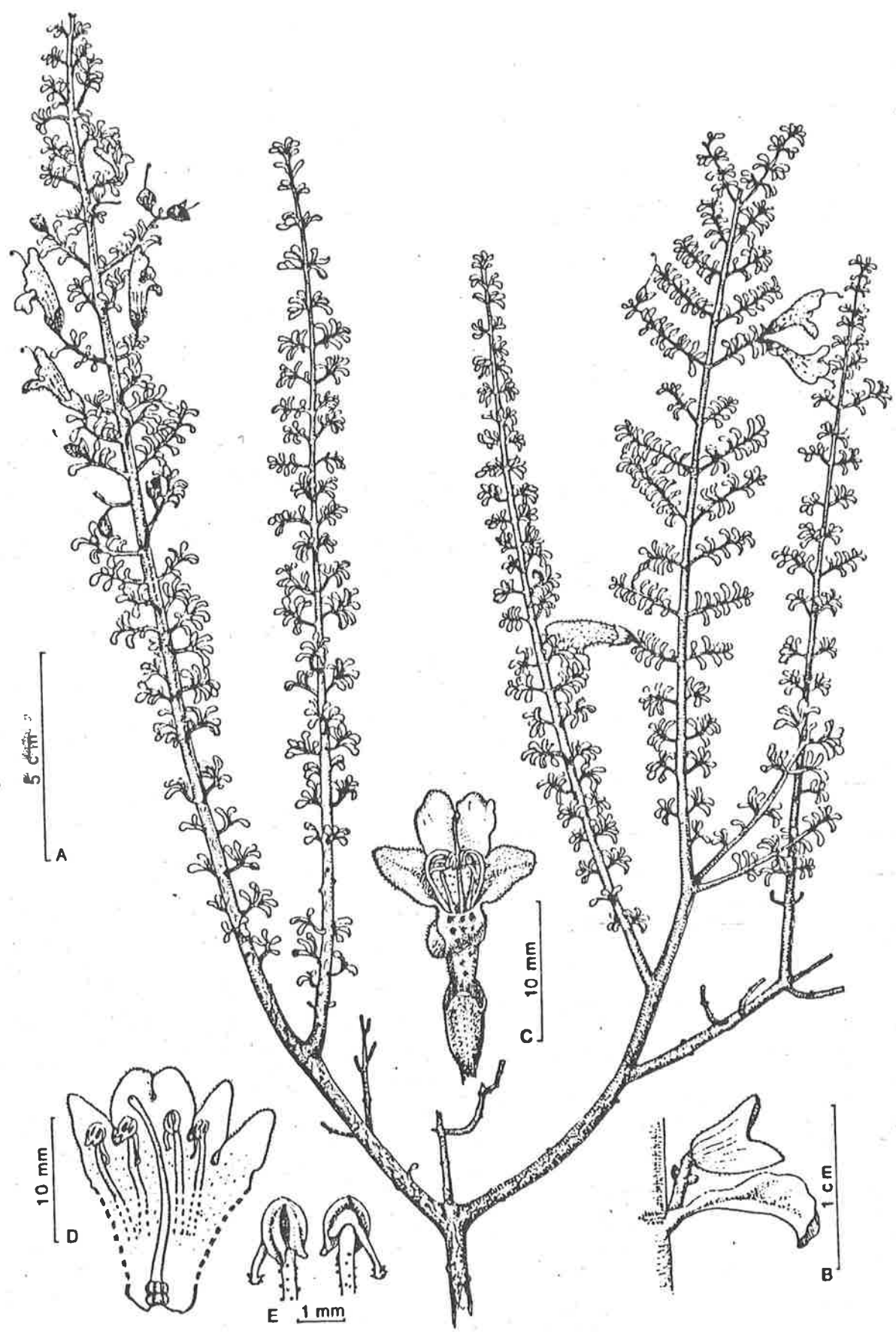
Distribution: Western Australia (Eremaean: Helms, Austin, Coolgardie; South-West: Avon, Roe).

Ecology: This species occurs on sandy soils, frequently amongst granite outcrops, or on compacted red clay - loams with laterites. Commonly associated with open dry sclerophyll woodland communities of *Acacia* spp., *Casuarina acutivalvis*, *C. campestris*, and *Eucalyptus* spp.

Note: *P. grylloana* is readily identified by its more or less conduplicate spathulate leaves. The outer surface of the calyx may appear glabrous because of the sparse indumentum and the very small hairs (cf. Eaton s.n., MEL 1512004).

The affinities of this species are not clear.

Fig. 73. *Prostanthera grylloana*. - A. twig and flowers; B. detail of leaf, pedicel, prophylls and calyx; C. flower - abaxial view; D. open corolla; E. stamens - ventral and dorsal views (all Willis s.n., MEL 43160).



Selected specimens examined: (60 collections)

WESTERN AUSTRALIA - Eremaean: Helms: Helms s.n., 16.ix.1891, Victoria Desert camp 54 (AD 96911024) - Austin: Fitzgerald s.n., -.x.1898, Bardoc (NSW 126688, 126690, 126691); Fraser 434/22, -.viii.1919, between Mt Marshall and Lake Barlee (NSW); Gardner & Blackall s.n., -.ix.1927, Comet Vale (PERTH); Jutson 277, -.viii.1917, Comet Vale (NSW). - Coolgardie: Alpin 1886, 9.ix.1962, 23 miles S of Coolgardie (PERTH); Blackall 950, 11.x.1931, near Bullabulling (PERTH); Chinnock 3114, 19.ix.1976, 40.2 km NNW of Bullfinch (AD); Davies 211, 2.v.1963, Spargoville (PERTH); George 4245, 22.ix.1962, 20 miles SW of Coolgardie (PERTH); Helms s.n., 12.xi.1891, Gnarlbine (AD 96911025, MEL 41914, NSW 126692); Phillips s.n. (CBG 26145), 6.ix.1968, 22 miles from Coolgardie towards Norseman (AD 96920341); Short 923, 12.xi.1979, Wargangering Rock (AD); Wilson 3461, 22.ix.1964, c. 1 km E of Walgoolan (AD).

South-West: Avon: Blackall 862, 3.x.1931, near Champion (PERTH); Chinnock 3127, 20.ix.1976, 9.8 km S of Warralakin (AD); Chinnock 5058, 6.xii.1980, 3 km NNE of Westonia (AD); Wilcox s.n., -.iv.1954, Warralakin Rock (PERTH); Merrall s.n., *anno* 1888, E sources of Swan River (MEL 43877). - Roe: Brockway 8, -.x.1944, Grasspatch (PERTH); Phillips s.n. (CBG 19296), 6.xi.1962, 1 mile N of Salmon Gums (NSW); Wrigley s.n. (CBG 33671), 12.xi.1968, 99 miles N of Esperance (AD, CBG).

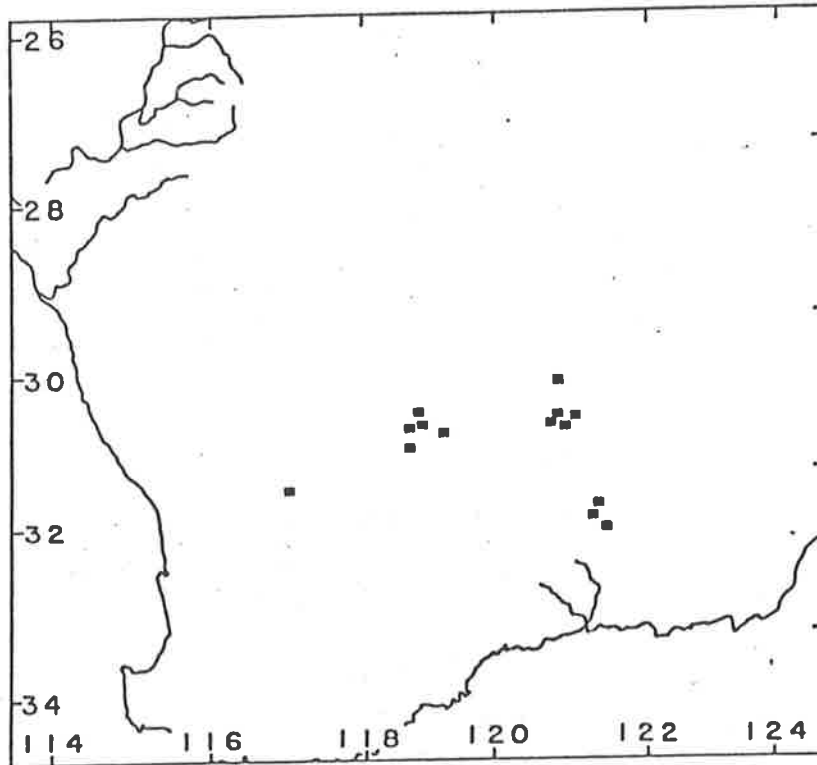


Fig. 74. Distribution map of *Prostanthera grylloana*.

13. *Prostanthera monticola* Conn, sp. nov. - Figs 75 & 76

'*Prostanthera* sp. aff. *P. walteri*': Althofer, Cradle of Incense
(1978) 116.

Species nova sectionis *Klanderiae*. Frutices 0.3 - 2 m. alti. Rami et ramuli subteretes usque subquadrangulares, tomentosi, pilis appressis, 0.3 - 0.4 mm. longis, internodiis iuvenibus saepe octo-porcatis. Petiolus foliorum (1.5-)2 - 5 mm. longus, tomentosus usque glabrescens; lamina angusta, oblanceolata usque elliptica, 15 - 50 mm. longa, 5 - 13 mm. lata, pagina abaxiali glabra, pagina adaxiali sparsim tomentosa vel glabra, basi cuneata usque subacuta, margine integro, recurvo, apice obtuso. Pedicellus florum 2 - 3 mm. longus, dense tomentosus, pilis circa 0.1 mm. longis, bracteolis ad basim calycis affixis, 10 - 18 mm. longis. Calyx 10 - 15 mm. longus, extra ad basim sparsim tomentosus usque glabrescens, alibi glaber; tubus 5 - 6 mm. longus; lobi ovati usque deltoidei, 6 - 9 mm. longi, 4 - 5 mm. lati, intra tomentosi, pilis circa 0.1 mm. longis, margine integro, apice obtuso usque angusto-acuto. Corolla 30 - 35 mm. longa, veneta; tubus 18 - 20 mm. longus, extra in partibus distalibus sparsim tomentosus; lobi intra sparsim tomentosi vel glabri, abaxiali-mediano plus minusve suborbiculari, 8 - 10 mm. longo, circa 10 mm. lato, margine irregulari, apice plus minusve rotundato, emarginato, sinu circa 1 mm. longo, lateralibus deltoideis, 7 - 8 mm. longis, circa 5 mm. latis, margine integro, apice subacuto usque acuto, adaxiali-mediano plus minusve ovato, leviter trilobo, circa 10 mm. longo, circa 12 mm. lato, margine integro, apice plus minusve obtuso, emarginato, sinu circa 1 mm. longo. Stamina circa 11 mm. e basi corollae affixa; filamenta 10 - 13 mm. longa; antherae 1.5 - 2 mm. longae, connectivo per trichomata deltoidea ultra loculis producto. Pistillum circa 25 mm. longum; ovarium circa 0.5 mm. longum; stylus 18 - 22 mm. longus; lobis

stigmatis circa 1 mm. longis. Fructus coccis 1.5 - 2 mm. longis.

Holotypus: Conn (& Campbell)731, 4.ii.1980, Crystal Brook Falls, Mt Buffalo, Eastern Highlands, Victoria (MEL; iso in AD, CANB).

Sprawling, open shrub, 0.3 - 2 m high. Branches subterete to subquadrangular, often with approximately 8 ridges distally, red, hairy, densely so on upper internodes and nodes, hairs appressed, 0.3 - 0.4 mm long, white. Leaves arranged along main axis and branches, not clustered; petiole (1.5-) 2 - 5 mm long, upper surface grooved, reddish when young, tomentose basally, sparsely tomentose to glabrescent distally, hairs c. 0.1 mm long, white; lamina narrow, lanceolate to elliptic, 15 - 50 x 5 - 13 mm, coriaceous, lower surface glabrous, upper surface sparsely tomentose (hairs c. 0.2 mm long, white) or glabrous, base cuneate to subacute, margin entire, recurved, apex obtuse; venation faint to indistinct, midrib raised on lower surface (usually with a few scattered hairs), sunken on upper surface (usually with red wart-like glands). Pedicel 2 - 3 mm long, flattened, densely tomentose, hairs c. 0.1 mm long, white; prophylls inserted at distal end of pedicel and so overlapping calyx, more or less linear, 10 - 18 mm long, equal to length of calyx or often extended beyond calyx, usually recurved, concave, abaxial surface sparsely minute-tomentose basally, glabrous distally, adaxial surface glabrous, apex more or less obtuse. Calyx 10 - 15 mm long, green; outer surface sparsely tomentose to glabrescent basally, glabrous distally; tube 5 - 6 mm long, inner surface with scattered pedicellate glandular trichomes; lobes ovate to deltoid, 6 - 9 mm long, 4 - 5 mm wide at base, inner surface minutely hairy, hairs c. 0.1 mm long, glabrous at apex, margin entire (not ciliate), apex obtuse to tapering-acute, apex of abaxial lobe often more obtuse than adaxial lobe. Corolla 30 - 35 mm long, pale blue-green to grey-green,

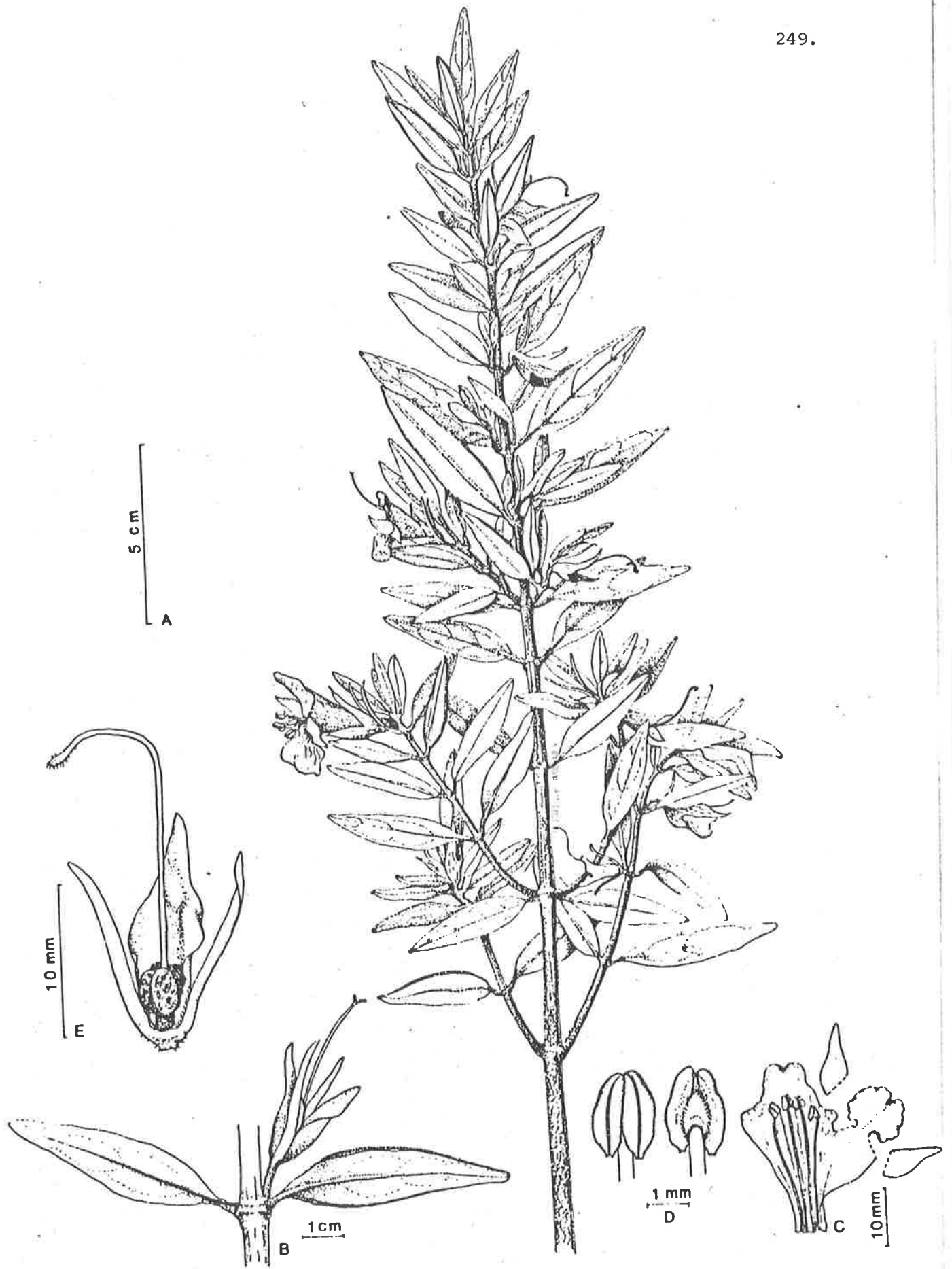
with dark purple-blue veins; tube 18 - 20 mm long, sparsely tomentose distally, especially medially and towards margin, lobes sparsely tomentose on outer surface, hairs c. 0.2 mm long; abaxial median lobe ± semi-orbicular, 8 - 10 mm long, c. 10 mm wide, sparsely pilose-tomentose medially, margin irregular, apex ± rounded, emarginate, sinus c. 1 mm long; lateral lobes triangular, 7 - 8 mm long, c. 5 mm wide at base, inner surface sparsely pilose-tomentose, margin entire, apex subacute to acute; adaxial median lobe-pair ± ovate, faintly 3-lobed, c. 10 mm long, c. 12 mm wide at base, inner surface glabrous, except often sparsely pilose-tomentose near margin between faint lobes, margin entire, apex ± obtuse, emarginate, sinus c. 1 mm long. Stamens inserted c. 11 mm above base of corolla; filaments 10 - 13 mm long; anthers 1.5 - 2 mm long, base of lobes with small acumen, connective slightly extended basally, with deltoid trichomes present, trichomes c. 0.2 mm long. Pistil c. 25 mm long; ovary up to c. 3 mm long, diameter at base c. 1 mm, lobes small; style 18 - 22 mm long; stigma lobes c. 1 mm long. Mericarps 1.5 - 2 mm long, distally extended c. 1 mm beyond base of style.

Distribution: New South Wales (Southern Tablelands) and Victoria (Eastern Highlands).

Ecology: Commonly associated with Eucalyptus delegatensis, E. pauciflora (E. niphophila), E. perriniana, E. stellulata or E. viminalis woodlands, commonly growing with Boronia algida, Bossiaea foliosa and/or Oxylobium alpestre, on deeply weathered granitic soils amongst granitic rocks.

Altitude 530 - 1833 m.

Fig. 75. *Prostanthera monticola*. - A. twig and flowers;
B. detail of leaves, pedicel, prophylls, calyx and style;
C. open corolla; D. stamens - ventral and dorsal views;
E. part of calyx removed to reveal mericarps and style
(all Carrick 3125).



Note: This species is very closely related to *P. walteri*. *P. monticola* has longer prophylls (10 - 18 mm long cf. 4 - 6.5 mm long in *P. walteri*) and the inner surface of the calyx-lobes are hairy (glabrous in *P. walteri*). Frequently, *P. walteri* has longer hairs on the vegetative parts than does *P. monticola* and the density of hairs is usually greater in the former species.

Both species appear to occupy a unique 'position' within sect. *Klanderia*. Both have large petiolate leaves (petiole 1.5 - 8 mm long; lamina 10 - 50 x 5 - 17 mm) which are more typical of sect. *Prostanthera*. The preliminary results from the volatile leaf oil analysis (p. 150) suggest that both species have very low amounts of terpenoids, whereas all other species of this section (which have been sampled) are relatively rich in terpenoids. Furthermore, *P. monticola* and *P. walteri* are the only species of sect. *Klanderia* which occur above the snow-line.

Although the distribution of this section is restricted, it is not considered to be conservationally endangered or vulnerable (Risk Code = 2R, [Conn, in] Leigh *et al.*, 1981, pp. 49 & 104 [as *P. walteri*]).

Selected specimens examined: (49 collections)

NEW SOUTH WALES. - Southern Tablelands: Ashby 2086 (collected by Stead), 16.i.1967, Schlink Pass road, near Geehi River crossing, Mt Kosciusko National Park (AD); Briggs 2542, 10.ii.1969, $\frac{1}{2}$ mile NW of Round Mt (AD); Costin s.n., 15.ix.1948, Big Badja Mountain (NSW 126710); Gittins 415, -.i.1962, Dickie Cooper Creek (NSW).

VICTORIA. - Beaglehole 17096, -.i.1950, lookout above where Crystal Brook drops down, Mt Buffalo (AD); Beaglehole 41681, 28.iii.1973, Mt Buffalo National Park, below Chalet (AD); Briggs s.n., 23.xii.1952, near Chalet,

Mt Buffalo National Park (NE); Cabbage 3686, 19.i.1913, Mt Buffalo (NSW, SYD); Carlisle s.n., -.iii.1893, Buffalo ranges (MEL 41923); Carrick 3011, 6.xii.1971, Mt Buffalo (AD); Conn & Campbell 731-735, 4.ii.1980, Crystal Brook Falls, Mt Buffalo (AD); Dunlop s.n., 14.i.1969, Creek below dam wall of Lake Catani, Mt Buffalo (CBG); French s.n., -.xii.1904, Buffalo ranges (MEL 41920, MEL 91921); Gauba 3305, 10.ii.1955, Mt Buffalo (AD); Gray & Totterdell 5826, 17.xii.1965, Mt Buffalo (CANB, NSW); Hill 1263, 31.xii.1963, Mt Buffalo plateau (AD); Kinnear s.n., -.i.1953, Mt Buffalo (AD); Muir 653, 2.i.1959, near Lake Catani, Mt Buffalo (AD, MEL, NSW); Nettie s.n., -.i.1923, Buffalo Mts (NSW 126711); Short 1383, 27.i.1982, c. 200 m down from summit of Mt McLeod (MEL); Walter s.n., -.xi.1903, Buffalo Mts (MEL 41922); Weindorfer s.n., 28.xii.1902, Buffalo Mts (NSW); Weindorfer s.n., -.xii.1903, Buffalo Mts (NSW 126714); Williamson s.n., 30.xii.1918, Buffalo Mts (NSW 126712); Willis s.n., 18.ii.1963, Mt Buffalo National Park (MEL 43787).

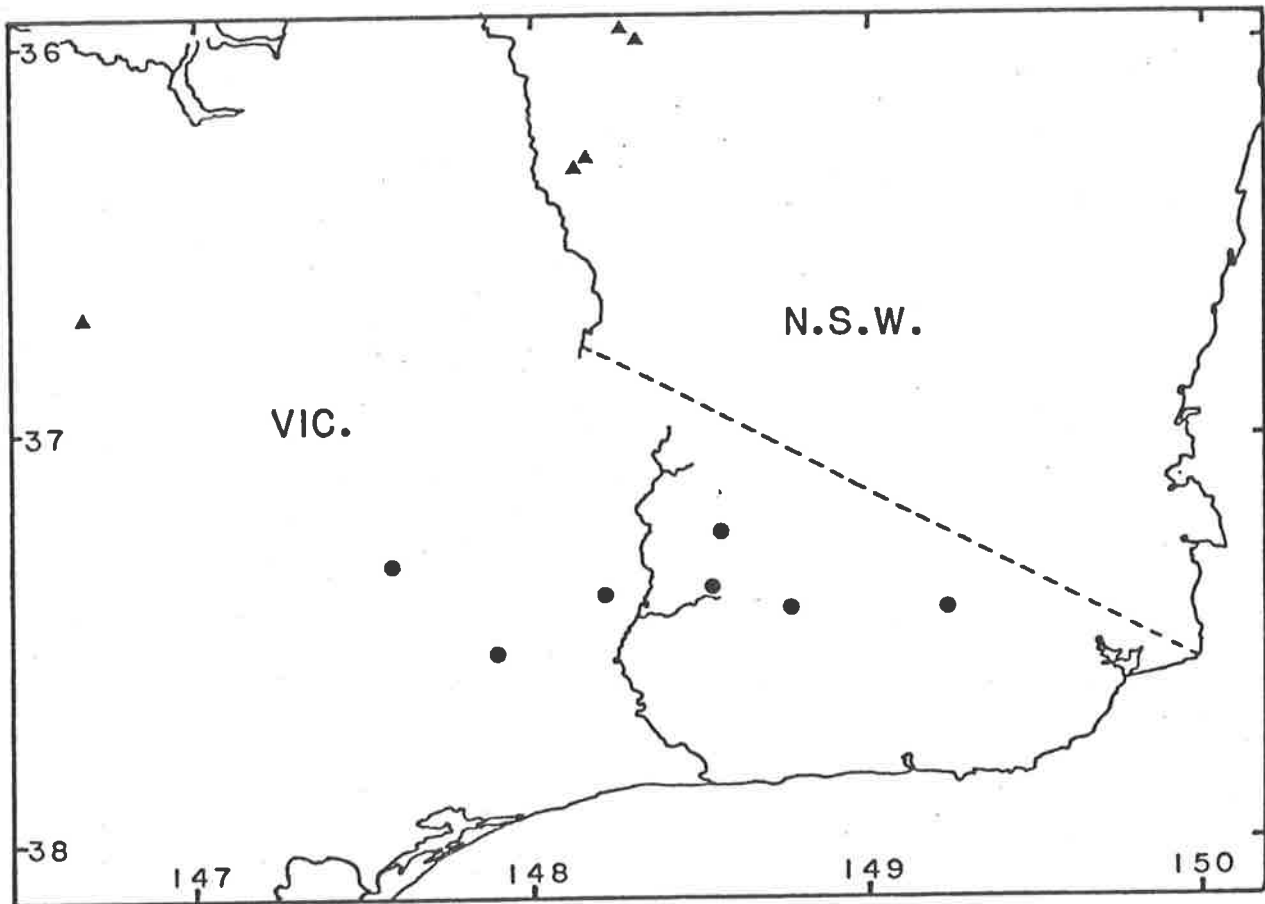


Fig. 76. Distribution map of *Prostanthera monticola* (▲) and *Prostanthera walteri* (●).

14. *Prostanthera walteri* F. v. Muell. - Figs 76 & 77

Prostanthera walteri F. v. Muell., *Fragm.* 7(1870)108; *Key Vict.* pl. 2(1885)42; *op. cit.* 1(1887)386; C. Moore, *Handb. fl. New S. Wales* (1893)352; Dixon, *Pl. New S. Wales* (1906)232; Guilfoyle, *Austral. pl.* (1911)306; Pescott, *Nat. fl. Victoria (s. dat. [1914])*99; Ewart, *Fl. Victoria* (1930)982; Harris, *Alpine pl. Austral.* (1970)142; Galbraith, *Wildfl. SE Austral.* (1977)326; Althofer, *Cradle of Incense* (1978)116, 119, 121, 122. - H o l o t y p e: C. Walter s.n., anno 1870, 'Mt Ellery, Gippsland', Victoria (MEL 41927).

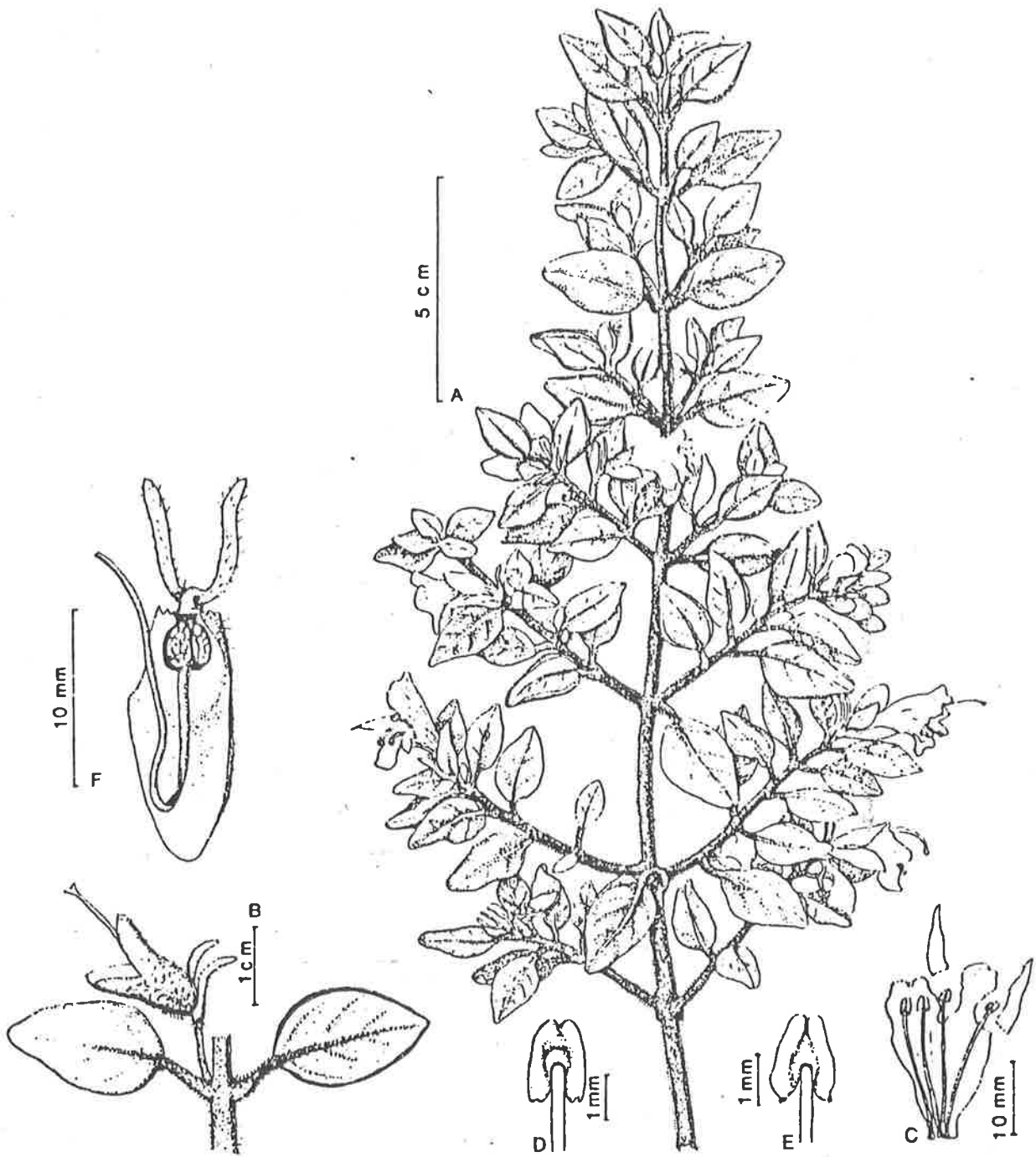
Sprawling shrub, 1 - 2 m high. Branches forming a tough wiry entanglement, ± terete, densely ± patent-pilose to appressed-tomentose, hairs (0.5-)0.8 - 1(-1.5) mm long and 0.1 - 0.3 mm long, respectively, hairs strongly curved when indumentum tomentose, glandular. Leaves arranged along main axis and branches, not clustered; petiole 2 - 5(-8) mm long, adaxial surface grooved, hairy, as for branches; lamina lanceolate, ovate to rhomboid-oval, (10-)18 - 26(-38) x 5 - 15(-17) mm, abaxial surface pilose to tomentose, hairs 0.5 - 0.8 mm long and 0.3 - 0.4 mm long, respectively, hairs strongly curved when indumentum tomentose, adaxial surface appearing glabrous, however sparsely minute-tomentose, especially on midrib, hairs up to c. 0.1 mm long, base obtuse, subacute to cuneate, margin entire, recurved, apex obtuse; venation faint, midrib raised on abaxial surface, slightly sunken on adaxial surface, veins mostly indistinct, slightly raised on abaxial surface, very slightly sunken adaxially. Pedicel 3 - 6 mm long, hairy, as for branches; prophylls inserted near distal end of pedicel (within 1 mm of calyx) and so overlapping calyx, linear-obovate, 4 - 6.5 mm long, usually recurved, concave, abaxial surface sparsely hairy to glabrescent, adaxial surface

glabrous, margin recurved, apex obtuse. Calyx 10 - 12 mm long, striate, outer surface pilose throughout or ± pilose at base, becoming glabrous or sparsely tomentose distally, or glabrous throughout, inner surface glabrous; tube 4 - 5 mm long; lobes broadly ovate, 3 - 6(-7) mm long, 5 - 7 mm wide at base, margin entire, apex obtuse to rounded. Corolla (15-)18 - 26 mm long, blue-green, rarely green-yellow, prominently purple-veined; tube 12 - 16 mm long, diameter at mouth 4 - 7 mm, outer surface sparsely tomentose distally, hairs up to 0.2 mm long, inner surface glabrous; lobes sparsely short-tomentose on outer surface, becoming denser near margin, inner surface glabrous, abaxial median lobe ± spatulate, 5 - 10 x 3 - 9.5 mm, c. 1.5 mm wide at base, apex rounded, irregular, slightly lobed; lateral lobes narrow oblong-lanceolate, (4-)5 - 7(-10) mm long, 1 - 1.5 mm wide at base, apex obtuse; adaxial median lobe-pair broadly ovate, 5 - 10 mm long, 6 - 10 mm wide at base, apex obtuse, slightly emarginate, sinus c. 0.5 mm long. Stamens inserted c. 10 mm above base of corolla; filaments c. 6 mm long, often with broad-deltoid glandular trichomes; anthers 1.5 - 2 mm long, base of lobes with small acumen, connective often extended on one side to form a basal appendage, appendage c. 0.4 mm long, with narrow-deltoid trichomes usually present, or appendage absent. Pistil 20 - 27 mm long; ovary 1 - 1.5 mm long, diameter at base c. 1 mm, lobes small; style 18 - 23 mm long; stigma lobes 0.5 - 1 mm long. Mericarps c. 2 mm long, distally extended c. 0.6 mm beyond base of style.

Distribution: Victoria (Eastern Highlands - East Gippsland).

Ecology: Commonly occurring in granitic soils, associated with *Eucalyptus obliqua*, *E. regnans*, *E. viminalis*, *Blechnum wattsii*, *Dicksonia antarctica* and *Pultenaea juniperina*. Altitude 1030 - 1400.

Fig. 77. *Prostanthera walteri*. - A. twig and flowers;
B. detail of leaves, pedicel, prophylls, calyx and style;
C. open corolla; D. stamens - dorsal view; E. stamen -
ventral view; F. part of calyx removed to reveal mericarps
and style (all Carrick 3033).



Notes: This species is very closely related to *P. monticola*. *P. walteri* is readily distinguished from *P. monticola* by its glabrous inner surface of the calyx (hairy lobes in *P. monticola*) and by its shorter prophylls. For further details refer 'Notes' for *P. monticola*.

Although the distribution of this species is restricted, it is not considered to be conservationally endangered or vulnerable (Risk Code = 2R, [Conn, in] Leigh *et al.*, 1981, pp. 49 & 110).

Selected specimens examined: (37 collections)

VICTORIA. - Eastern Highlands (East Gippsland): Beaglehole 34062, 20.ix.1970, Mt Kaye (AD); Beaglehole 35729, 3.i.1971, Monkey Top Track, S of Bowen Range (AD); Beaglehole 37084, 27.ii.1971, W of Mt Baldhead, Bruthen road (AD); Beaglehole 37111, 28.ii.1971, Mt Elizabeth II, north side (AD); Beaglehole 37726, 2.iv.1971, Yalmy road, Yalmy river area (AD); Carrick 3033, 3036, 8.xii.1971, Summit of Mt Ellery (AD); Conn 709 - 714, 1.xii.1979, Mt Ellery (AD); Conn 724 - 726, 2.xii.1979, Mt Elizabeth No. 2 (AD); Czornij 441, 8.xii.1971, Summit of Mt Ellery (AD); French s.n., -.i.1889, Summit of Mt Ellery (MEL 41918); French s.n., s. dat. E. Gippsland (P); Hodge s.n., 13.ii.1948, main top E of "W-Tree" (MEL 41929), Hodge s.n., 23.iv.1957, cultivated at W-Tree (MEL 41925); Howitt 15, anno 1884, Gippsland (MEL 41926); Purdie 289, anno 1894, Mt Ellery (MEL 41919); Wakefield s.n., 20.xi.1947, Summit of Mt Kaye, upper Cann River valley (MEL 43784); Walter s.n., anno 1870, Mt Ellery (MEL 41927) (TYPE); Walter s.n., anno 1871, Gippsland (MEL 41917); Willis s.n., 17.xi.1968, Yalmy river track between Buchan & Goongerah (AD 97609146, MEL 43786); Willis & Wakefield s.n., 16.x.1948, Mt Kaye (MEL 43785); Willis & Wakefield s.n., 29.xii.1951, Mt Ellery (AD 97609145, MEL 43782, MEL 43783).

Nomen sedis incertae

Prostanthera caleyi Benth., Labiat. gen. spec. (1834)454; in DC., Prodr. 12(1848)562. - T y p e: Caley s.n. in herb Lambert, s. dat., 'Hab. in Nova Hollandia' (?BM, n.v.).

Notes: The status of this species is unknown and I have not located collections which are referable to the protologue (Bentham 1834). Bentham (1870) also regarded the status of this species as uncertain. He was unable to re-examine the material 'owing to the dispersion of the Lambertian herbarium' (Bentham 1870; also refer Stafleu & Cowan 1979). Since most of Caley's collections are held at the British Museum (BM) (Stafleu & Cowan 1976), it seems likely that the type of this taxon, may be held there. Unfortunately, collections on loan from the British Museum were returned before this taxon was considered.

Bentham (1834) regarded *P. caleyi* as closely related to *P. aspalathoides*. However, the long anther appendage ('*antherarum calcare longiore loculum subaequante*') and the ovate-elliptic leaves makes it less likely to be closely related to this species. Bentham (1870) tentatively suggested that the relationship was possibly more likely to be with *P. chlorantha*. However, Caley did not visit South Australia (Currey 1966) and so, could not have collected *P. chlorantha* or any species closely related to it. Since he only collected from the eastern States (as far west as Westernport Bay in Victoria, and south to Tasmania), this taxon is probably from section *Prostanthera*.

APPENDIX

INDEX TO COLLECTIONS USED IN THE NUMERICAL ANALYSES

Collections used for the numerical taxonomic treatment of *Prostanthera aspalathoides*, the *P. calycina* - *P. microphylla* - *P. serpyllifolia* complex, and the *P. laricoides* complex are listed below. Collections are arranged alphabetically by collector's name and under these in numerical order. Dutch, French and German names are arranged according to their first major part, viz. after 'de', 'van der', 'von', etc. Collection numbers are all followed by a colon and the number of the relevant taxa as indicated below. The number sequence follows that used in the 'Systematic Treatment' (pp. 152 - 255). Anonymous collections are listed first. Collections without numbers are listed with the herbarium sheet number, if known, or by the date of the collection. If neither are known, then the herbarium is listed.

(a) Names of taxa of *Prostanthera* section *Klanderia* with their key numbers

2. *P. serpyllifolia*
3. *P. patens*
4. *P. calycina*
5. *P. aspalathoides*
6. *P. florifera*
7. *P. pedicellata*
8. *P. incurvata*
9. *P. semiteres*
10. *P. laricoides*

(b) Enumeration of collections

Anon. s.n. (AD 966032930): 2, (AD 97244338): 5, (MEL 43390): 2, (MEL 43398):
 2, (MEL 43405): 2, (MEL 43409): 2, (NSW 126667): 5, (W 7225): 5; Ackland 24:
 5, 82: 5; Ainslie s.n. (AD 96727335): 2; Aitken s.n. (AD 98108051): 5;
Alcock s.n. (AD 96439007): 2, (AD 96532033): 5, 631: 2, 632: 2, 633: 5,
807: 2, 1005: 2, 1006: 2, 1568: 2, 2202: 2, 2260: 2, 2351: 2, 2745: 4, 4539:
 2, B38: 2; Alpin 2551: 3; Althofer 33: 2; d'Alton s.n., anno 1895: 5,
 -.x.1899: 2, (NSW 128303): 5; Anway 340: 2; Armitage 522: 2; Ashby s.n.
 (AD 966020785): 5, (AD 966041105): 2, 195: 2, 282: 5, 2993: 7, 3585: 9,
3931: 7, 5035: 7, 5112: 7, 5209: 3, 5220: 3; Aston 439: 5; Audas s.n.,
 -.ix.1934: 5.

Bale 123: 8; Barker 3639: 2, 4133: 5; Bates 780: 2; Beard 2362: 2, 4744: 9,
5408: 2, 5944: 9, 6329: 2, 6687: 7; Beaglehole 1064: 2, 16993: 5, 16994: 5,
17538: 2, 17572: 5, 17575: 2, 28296: 5, 28757: 5, 40142: 5, 40386: 2;
Beaglehole (& Finck) 29015: 5, 29111: 5, 29566: 2; Beaglehole (& Kraehen-
buehl) 17049: 5; de Beuzeville s.n. (NSW 126669): 5; Beveridge s.n. (MEL
 42942): 5; Beythieu 91: 2, 92: 2; Blackall 896: 9, 979: 8, 3452: 9;
Blackburn s.n. (ADW 25864): 5; Blaylock 70: 2, 509: 5, 1092: 2, 1124: 2,
1306: 5; Boomsma 278: 5; Boorman s.n., -.x.1906: 5, 30.xi.1917; Boswell
F66: 10; Bourke s.n., 16.viii.1968: 5; Bourne s.n., 17.viii.1968: 2;
Brickhill s.n., 3.x.1979: 5, 161: 2; Broadbent 1054: 8; Brooke s.n.,
 -.x.1901: 2, (NSW 126720): 2; Browne s.n. (MEL 43407): 2, (NSW 126664): 5,
 (NSW 134450): 2; Brymer s.n. (NSW 126676): 5; A. Burbidge s.n. (AD 97142003):
 5, (AD 97142004): 2; N. Burbidge 2664: 8; Burns 1037/2: 3; Butler s.n.,
 26.i.1959: 10.

Cadwell 9: 2; Canning s.n. (CBG 23603): 2, (CBG 23620): 2, (CBG 26146): 8,
 (CBG 34141): 2, (CBG 39694): 5; Carrick 2944: 5, 2980: 5, 3192: 2, 3195: 5,
3196: 5, 3306: 5, 3307: 5, 3308: 5, 3309: 5, 3425: 2, 3434: 2, 3507: 5,
3508: 5, 3901: 2, 3902: 2, 3903: 2, 3904: 2, 3905: 2, 3906: 2, 3907: 2,
3908: 2, 3909: 2, 3910: 2, 3911A: 2, 3911B: 2, 3912: 2, 3913: 2, 3941: 2;
Carroll s.n. (CBG 23845): 5; Cashmore s.n. (ADW 1862): 5; Caulfield 25: 2,
236: 2; Chapman s.n., 9.ix.1909: 5; Chinnock 2746: 5, 2790: 2, 3055: 8,
3132: 9; Clark s.n. (AD 966042262): 2; Cleland s.n. (AD 96601453): 2,
 (AD 96601792): 2, (AD 966031299): 5, (AD 966031566): 5, (AD 966031591): 5,
 (AD 966031652): 2, (AD 966071647): 5, (AD 966081574): 5, (AD 966081581): 2,
 (AD 96680266): 5, (AD 97208149): 5, (AD 97217178): 2, (AD 97217259): 5,
 (AD 97219044): 2, (AD 97315372): 2; Conn 675: 6, 679: 6, 680: 6, 684: 2,
694: 5, 697: 5, 698: 5, 703: 5, 760: 5, 761: 5, 762: 5, 763: 5, 764: 5,
765: 5, 767: 5, 768: 5, 776: 5, 783: 5, 1040: 5, 1042: 5; Conn et al. 1043:
 5, 1044: 5, 1047: 5, 1048: 5, 1049: 5, 1050: 5, 1051: 5, 1052: 5, 1053: 5,
1054: 5, 1055: 5, 1056: 5, 1057: 5, 1058: 5, 1059: 5, 1060: 5, 1061: 5,
1062: 5, 1063: 5, 1064: 5, 1065: 5, 1067: 5, 1068: 5, 1069: 5, 1070: 5,
1071: 5, 1072: 5, 1073: 2, 1077: 2, 1078: 2, 1079: 2, 1080: 2, 1089: 2,
1090: 2, 1091: 2, 1093: 2, 1096: 2, 1097: 2; Constable 5230: 5; Cooper s.n.,
 3.i.1950: 5, 26.viii.1964: 5; Copley 770: 2, 1408: 5, 1942: 5, 2285: 2,
3043: 5, 3145: 2, 4025: 5, 4091: 2, 4423: 2, 4424: 2, 4425: 2, 4519: 2, 4520:
 2, 4619: 2, 4801: 2, 4858: 4, 4897: 2; Corrick 6317: 5, 6365: 2; Crisp 528:
 2, 529: 5, 529A: 5, 1446: 2, 1506: 5; Crocker s.n. (ADW 4340): 5; Cronin s.n.
 (MEL 43868): 2; Cunningham 264: 5, 1306: 2, 1407: 5, 1817: 2; Curran s.n.,
anno c. 1890: 5, (MEL 42934): 5; Curdie s.n. (MEL 42935): 5; Czornij 364: 5.

Dallachy s.n. (MEL 42939): 5; Davies s.n., -.xii.1962: 2; Debenham s.n.,
-.x.1968: 5; Demarz 5261: 9; Dennis 170: 4; Donner 1871: 2, 2267: 2, 2333:
2, 2484: 2, 2752: 2, 2964: 2, 3693: 5; Dwyer s.n. (NSW 126670): 5.

Eichler 15172: 2, 15251: 5, 15484: 5, 15490: 2, 18320: 5, 18538: 2, 19171: 2,
19193: 2, 19373: 2, 20011: 2.

Fagg 542: 5; Filson 604: 5; Francis s.n. (AD 96911083): 5.

Gardner s.n., 3.ix.1923: 2, 2060: 9, 2797: 9, 14828: 2; Gaubas s.n., 12.ii.1953:
5; Gemmell 147: 5, 291: 5; George 2670: 9, 8519: 2; Gill 152: 2; Grivell s.n.
(AD 97050460): 2, (AD 97050461): 5, (AD 97050462): 5.

Hassall s.n. (MEL 43861): 2; Hately s.n. (MEL 42913): 5; Henshall s.n.
(AD 97020142): 5, (NSW 126671): 5; Hergstrom s.n. (AD 97408316): 5; Heyligers
80127: 2; Hicks 136: 5; Hill 652: 2, 1078: 2, 1079: 2, 1080: 2; Hilton s.n.
(ADW 18964): 2, (ADW 18965): 2; Hincks s.n. (AD 96228206): 5; Hockley s.n.
(ADW 24987): 5; Hunt 234: 5, 3380: 5; Hussey s.n., -.ix.1898: 5, 281: 5.

Ingram 446.07: 5, 447.071: 5; Ising s.n. (AD 966070092): 2, (AD 966081679): 5,
(AD 97249330): 5, (AD 97249342): 2, (AD 97651310): 2, (AD 97651311): 2,
(AD 97651333): 2, (AD 97703492): 2, 1039: 5, 3189: 5; Ising (& Rothe) s.n.
(AD 97650191): 5.

E. Jackson 2641: 2, 3656: 2; G. Jackson 43: 5, 77: 5, 78: 5, 165: 5, 285: 5,
376: 2, 392: 5, 852: 2; Jordan s.n., -.viii.1953: 5.

Kaspiew 2235: 2; Kemsley s.n. (MEL 43820): 8; Kirkpatrick s.n. (AD 97122059):
2; Koch 2187: 2; Kraehenbuehl s.n. (MEL 1011647): 5, 184: 5, 864: 2, 913: 2,
1233: 5; Kraehenbuehl (& Alcock) 2061: 2; Kuchel 1305: 2, 1720: 2.

Laryon s.n. (NSW 126672): 5; Laver s.n. (ADW 9001): 5; Lay 686: 2; Lidgey
5 & 7: 8; Lothian s.n. (AD 96322062): 5, 2638: 2; Lothian (& Francis) 706:
5; Lucas 28: 5; Luchman s.n. (MEL 42945): 5.

Mack s.n. (AD 97347139): 5; Maiden s.n. (NSW 126722): 7; Main s.n.,
9.xii.1953: 10; Martin s.n. (AD 966072236): 5; Melville 1310: 5; Melville
(& Hicks) 1085: 5; McCauley 10: 2; McDougall 30: 2; Milewski s.n.,
-.x.1980: 3; Mitchell s.n. (NSW 126662): 5, (NSW 126663): 5, 10: 2;
Morris 1527: 5; von Mueller s.n. (MEL 43392): 2, 121: 2; Muir 1121: 2;
Mulham W384: 5; Munir 5059: 5, 5060: 5.

Nash s.n. (AD 96450191): 2; Newbey 463: 2, 2538: 9; Nicholls s.n. (MEL
42914): 5.

Oliver s.n. (MEL 43394): 2; Orchard 2138: 2, 2143: 5, 2168: 6, 2230: 6,
2329: 6, 2943: 5.

Parker s.n. (ADW 1864): 2; Paust 845: 2; Pearce s.n. (ADW 29295): 5,
(ADW 29296): 5; Phillips s.n., 28.ix.1965: 2, (CBG 6653): 4, (CBG 10370): 5,
(CBG 1161): 2, (CBG 13635): 2, (CBG 17049): 5, (CBG 23260): 8, (CBG 23274):
8, (CBG 23546): 2, (CBG 23619): 5, (CBG 23621): 2, (CBG 23626): 5, (CBG 23783):
2, (CBG 23838): 2, (CBG 23829): 2, (CBG 23840): 5, (CBG 23846): 2, (CBG 31378):
2, (CBG 38610): 5, (CBG 54467): 7; Puckridge s.n. (AD 96601728): 2; Pulleine
s.n. (AD 96909005): 5, (ADW 14038): 5.

Reader s.n., *s. dat.* (HBG): 5, 18.ix.1893: 5, 27.ix.1896: 2, -.x.1906: 2, (MEL 43412): 2, (MEL 43413): 2; Reid s.n. (ADW 38049): 2; Richards s.n. (MEL 41898): 4; Rogerson 61: 2; Rohrlach 158: 2, 625: 2, 952: 2; Rosier 59: 2, 309: 9; Rosier (& Harvey) 251: 9; Royce 3540: 2, 5371: 10, 5472: 10, 6703: 2, 9302: 2, 10128: 2.

Saddler s.n. (ADW 32193): 5; Sharrad 241: 2, 800: 5, 887: 2, 1095: 5, 1193: 5; H. Smith s.n., 6.x.1931: 5; T. Smith 779: 2; van der Sommen s.n. (AD 97449148): 5; Specht 2067: 2, 2300: 5, 2360: 2, 2479: 2, 2706: 2; Spooner 992: 5, 6171: 2; Steenbohm s.n., -.x.1961: 3; Sutton s.n. (MEL 43411): 5; Symon 3594: 5, 4196: 2, 6158: 2, 6192: 2, 6229: 2, 6319: 2, 6320: 2, 6426: 2, 8634: 5, 8660: 2, 8716: 2.

Tepper s.n. (AD 96911031): 2, (MEL 43401): 2; Tindale s.n., -.x.1963: 5, 463: 2, 589: 2, 590: 2; Trainee 75: 5.

Veitch s.n. (AD 966051161): 2.

Wace s.n. (AD 97247329): 2; Wade s.n. (AD 97651332): 5; Walter s.n., *s. dat.* (GH): 2, *anno* 1892: 5, -.xi.1905: 5, (W 7225): 5; Warburton s.n. (MEL 41899): 4; Warnes s.n. (AD 96850109): 2; Watts s.n. (NSW 126674): 5, (NSW 126675): 5; Weber 3584: 5, 4254: 2, 4342: 2, 5188: 9, 6210: 4; Weindorfer 83: 2; Whaite 2455: 5, 2726: 2, 2753: 5; Wheeler 457: 2, 561: 2, 647: 2, 584: 2, 748: 2, 801: 2, 888: 2, 1130: 2, 1308: 2; Whibley 279: 2, 576: 2, 1961: 2, 1992: 2, 3636: 5, 3645: 5, 7323: 5, 7462: 5, 7350: 2, 7426: 2, 7435: 2; Williams 1037: 2, 1038: 5, 1039: 5; Willis s.n. (MEL 41897): 4, (MEL 42910): 5, (MEL 42911): 5, (MEL 42912): 5, (MEL 42994): 2; Wilson 246:

2, 410: 2, 411: 2, 2089: 5, 2741: 5, 3112: 8, 3508: 9, 3515: 9; Wittwer 1411:
2; Wollaston s.n. (AD 97205031): 5; Woolmer 53: 5; Wrigley s.n.
(AD 97122124): 4, (CBG 36467): 2, (CBG 36470): 5, (CBG 44751): 2, (CBG
46128): 2, WA/68 7747: 2.

Yarrington s.n. (MEL 42920): 5, 3: 5.

REFERENCES

- Adams, R.P. (1969). "Chemosystematic and numerical studies in natural populations of Juniperus". (Unpubl. Ph. D. dissertation. Univ. of Texas, Austin).
- Adams, R.P. (1970a). Seasonal variation of terpenoid constituents in natural populations of Juniperus pinchotii Sudw. Phytochemistry 9: 397-402.
- Adams, R.P. (1970b). Chemosystematic and numerical studies of natural populations of Juniperus ashei Buch. Taxon 19: 728-751.
- Adams, R.P. (1970c). Contour mapping and differential systematics of geographic variation. Syst. Zool. 19: 385-390.
- Adams, R.P. (1972a). Chemosystematic and numerical studies of natural populations of Juniperus pinchotii Sudw. Taxon 21: 407-427.
- Adams, R.P. (1972b). Numerical analysis of some common errors in chemosystematics. Brittonia 24: 9-21.
- Adams, R.P. (1974). Computer graphic plotting and mapping of data in systematics. Taxon 23: 53-70.
- Adams, R.P. (1975). Statistical character weighting and similarity stability. Brittonia 27: 305-316.
- Adams, R.P. (1979). Diurnal variation in the terpenoids of Juniperus scopulorum (Cupressaceae) - summer versus winter. Amer. J. Bot. 66: 986-988.
- Adams, R.P. & A. Hagerman (1976). A comparison of the volatile oils of mature versus young leaves of Juniperus scopulorum: chemosystematic significance. Biochem. Syst. Ecol. 4: 75-79.

- Adams, R.P. & A. Hagerman (1977). Diurnal variation in the volatile terpenoids of Juniperus scopulorum (Cupressaceae). Amer. J. Bot. 64: 278-285.
- Adams, R.P. & B.L. Turner (1970). Chemosystematic and numerical studies of natural populations of Juniperus ashei Buch. Taxon 19: 728-751.
- Althofer, G.W. (1978). "Cradle of incense. The story of Australian Prostanthera". (Soc. Growing Austral. Plants: Sydney).
- Anderson, R.H. (1961). Introduction. Contr. New S. Wales Natl. Herb. New S. Wales, Nos 1-18: 1-15.
- Armstrong, J.A. (1979). Biotic pollination mechanisms in the Australian flora - a review. New Zealand J. Bot. 17: 467-508.
- Armstrong, J.A., J.M. Powell & A.J. Richards (Eds) (1982). "Pollination and evolution". (Royal Bot. Gardens Trust: Sydney).
- Attaway, J.A., A.P. Pieringer & L.J. Barabas (1967). The origin of Citrus flavour components - III. A study of the percentage variations in peel and leaf oil terpenes during one season. Phytochemistry 6: 25-32.
- Bailey, F.M. (1901). Labiatae. In "Queensland flora". (Govt Printer: Brisbane), vol. 4, p. 1204.
- Bailey, N.T.J. (1959). "Statistical methods in biology". (Hodder & Stoughton: London).
- Barker, W.R. (1982). Taxonomic studies in Euphrasia L. (Scrophulariaceae). A revised infrageneric classification, and a revision of the genus in Australia. J. Adelaide Bot. Gard. 5: 1-310.

- Bartling, F.G. (1830). "Ordines naturales plantarum". (Dieterich: Göttingen).
- Beadle, N.C.W., O.D. Evans & R.C. Carolin (1976). "Flora of the Sydney region". (A.H. & A.W. Reed: Sydney).
- Beard, J.S. (1980). A new phytogeographic map of Western Australia. Western Austral. Herb. Res. Notes 3: 37-58.
- Bendz, G. & J. Santesson (Eds) (1973). "Chemistry in botanical classification". Nobel Symposium 25. (Nobel Foundation: Stockholm & Academic Press: New York).
- Bentham, G. (1834). "Labiatarum genera et species". (J. Ridgeway & Sons: London), pp. 448-456.
- Bentham, G. (1870). Labiatae. In "Flora Australiensis". (Reeve: London), vol. 5, pp. 70-137.
- Bentham, G. & J.D. Hooker (1876). "Genera plantarum". (Reeve & Co.: London), vol. 2: 1160-1223.
- Blackburn, D.T. (1980). A generalized distance metric for the analysis of variable taxa. Bot. Gaz. 14: 325-335.
- Blackith, R.E. & R.A. Reyment (1971). "Multivariate morphometrics". (Academic Press: London).
- Bonner, J. (1950). "Plant biochemistry". (Academic Press: New York).
- Briggs, B.G. & L.A.S. Johnson (1979). Evolution in the Myrtaceae - evidence from inflorescence structure. Proc. Linn. Soc. New S. Wales 102: 157-256.
- Briquet, J. (1895). Labiatae p.p.. In Engler, A. & K. Prantl (Eds), "Die Natürlichen Pflanzenfamilien". (Engelmann: Leipzig), Teil IV, Abteilung 3a, pp. 183-221.

- Brown, R. (1810). "Prodromus Florae Novae Hollandiae". (J. Johnson & Co.: London).
- Burbidge, N.T. (1955). "An index to the microfilm of Robert Brown's botanical descriptions (Manuscript) of Australian plants held by the British Museum (Natural History)". (C.S.I.R.O.: Canberra).
- Burbidge, N.T. (1956). Robert Brown's Australian collecting localities. Proc. Linn. Soc. New S. Wales 80: 229-233.
- Cain, A.J. & G.A. Harrison (1958). An analysis of the taxonomist's judgement of affinity. Proc. Zool. Soc. London 131: 85-98.
- Cantino, P.D. (1982). Affinities of the Lamiales: A cladistic analysis. Syst. Bot. 7: 237-248.
- Carrick, J. (1976). Studies in Australian Lamiaceae 1. Genus Wrixonia F. Muell. (Prostantheroideae). J. Adelaide Bot. Gard. 1: 27-34.
- Carrick, J. (1977). Studies in Australian Lamiaceae 2. Eichlerago a new genus allied to Prostanthera. J. Adelaide Bot. Gard. 1: 115-122.
- Chatfield, C. & A.J. Collins (1980). "Introduction to multivariate analysis". (Chapman & Hall: London).
- Cheng, Y.S. & E. von Rudloff (1970). The volatile oil of the leaves of Chamaecyparis nootkatensis. Phytochemistry 9: 2517-2527.
- Churchill, D.M., T.B. Muir & D.M. Sinkora (1978). The published works of Ferdinand J.H. Mueller (1825-1896). Muelleria 4: 1-120.
- Clifford, H.T. & W. Stephenson (1975). "An introduction to numerical classification". (Academic Press: New York).
- Clifford, H.T. & W.T. Williams (1973). Classificatory dendrograms and their interpretation. Austral. J. Bot. 21: 151-162.

- Cochrane, G.R., B.A. Fuhrer, E.R. Rotherham & J.H. Willis (1968).
"Australian flora in colour. Flowers and plants of Victoria".
(A.H. & A.W. Reed: Sydney).
- Conn, B.J. (1980). A taxonomic revision of Geniostoma subg. Geniostoma
(Loganiaceae). Blumea 26: 245-364.
- Cooley, W.W. & P.R. Lohnes (1971). "Multivariate data analysis".
(J. Wiley & Sons: New York).
- Copley, P.B. (1982). A taxonomic revision of the genus Ixodia (Asterac-
eae). J. Adelaide Bot. Gard. 6: 41-54.
- Corner, E.J.H. (1976). "The seeds of dicotyledons". 2 vols. (Cambridge
Univ. Press: Cambridge).
- Cramér, H. (1946). "Mathematical methods of statistics". (Princeton
Univ. Press: Princeton).
- Cronquist, A. (1968). "The evolution and classification of flowering
plants". (Thomas Nelson & Sons: London).
- Cronquist, A. (1981). "An integrated system of flowering plants".
(Columbia Univ. Press: New York).
- Cunningham, G.M., W.E. Mulham, P.L. Milthorpe & J.H. Leigh (1982).
"Plants of western New South Wales". (D. West, Govt Printer:
Sydney).
- Currey, J.E.B. (Ed) (1966). "Reflection on the colony of New South
Wales. George Caley". (Angus & Robertson: London).
- Dagnelie, P. (1966). A propos des différentes méthodes de classification
numerique. Rev. Statist. Appl. 14: 55-75.
- Davis, P. H. & V.H. Heywood (1963). "Principles of Angiosperm taxonomy".
(Oliver & Boyd: Edinburgh).

- Ehrlich, P.R. & P.H. Raven (1965). Butterflies and plants: a study in coevolution. Evolution 18: 586-608.
- Emboden, W.A. Jr & H. Lewis (1967). Terpenes as taxonomic characters in Salvia section Audibertia. Brittonia 19: 152-160.
- Faegri, K. & L. van den Pijl (1979). "The principles of pollination ecology". 3rd ed. (Pergamon Press: London).
- Farris, J.S. (1966). Estimation of conservatism of characters by constancy within biological populations. Evolution 20: 587-591.
- Farris, J.S. (1977). On the phenetic approach to vertebrate classification. In Hecht, M.K., B.M. Hecht & P.C. Goody (Eds), "Major patterns in Vertebrate evolution". (Plenum Press: New York), pp. 823-850.
- Field, B. (Ed.) (1825). "Geographical memoirs on New South Wales; by various hands:" (John Murray: London), pp. 332-333.
- Firmage, D.H. & R. Irving (1979). Effect of development on monoterpene composition of Hedeoma drummondii. Phytochemistry 18: 1827-1829.
- Fisher, F.J.F. (1968). The role of geographical and ecological studies in taxonomy. In Heywood, V.H. (Ed.), "Modern methods in plant taxonomy". (Academic Press: London).
- Florek, K., J. Łukaszewicz, J. Perkal, H. Steinhaus & S. Zubrzycki (1951a). Sur la liason et al division des points d'un ensemble fini. Colloquium Math. 2: 282-285.
- Florek, K., J. Łukaszewicz, J. Perkal, H. Steinhaus & S. Zubrzycki (1951b). Taksonomia Wrocławska. Przepl. Antropol. 17: 193-211.
- Ford, H.A. & D.C. Patton (1976). The value of insects and nectar to honeyeaters. Emu 76: 83-84.

- Ford, H.A., D.C. Patton & N. Forde (1979). Birds as pollinators of Australian plants. New Zealand J. Bot. 17: 509-519.
- Forss, D.A. & G.L. Holloway (1967). Recovery of volatile compounds from Butter oil. J. Amer. Oil Chemists Soc. 44: 572-575.
- Fraenkel, G.S. (1959). The raison d'être of secondary plant substances. Science 129: 1466-1470.
- Gardner, C.A. (1931). "Enumeratio plantarum Australiae occidentalis". (Govt. Printer: Perth).
- Gentilli, J. (1972). "Australian climate patterns". (Nelson: Melbourne).
- Gotteberger, G. (1971). Colour changes of petals in Malvaviscas arboreus flowers. Acta Bot. Neerl. 20: 381-388.
- Gould, S.J. & R.F. Johnston (1972). Geographic variation. Annu. Rev. Ecol. Syst. 3: 457-498.
- Gower, J.C. (1966). Some distance properties of latent root and vector methods used in multivariate analysis. Biometrika 53: 325-338.
- Gower, J.C. (1967). Multivariate analysis and multidimensional geometry. Statistician 17: 13-28.
- Gower, J.C. (1969). A survey of numerical methods useful in taxonomy. Acaralogia 11: 357-375.
- Grant, K.A. & V. Grant (1968). "Hummingbirds and their flowers". (Columbia Univ. Press: New York).
- Green, J.W. (1980). A revised terminology for the spore-containing parts of anthers. New Phytol. 84: 401-406.
- Haegi, L. (1981). Labiatae (Lamiaceae). In Jessop, J. et al. (Eds), "Flora of Central Australia". (Austral. Syst. Bot. Soc., A.H. & A.W. Reed: Sydney).

- Hagmeir, E.M. (1958). Inapplicability of the subspecies concept to North American Marten. Syst. Zool. 7: 1-7.
- Hallé, F., R.A.A. Oldeman & P.B. Tomlinson (1978). "Tropical trees and forests. An architectural analysis". (Springer-Verlag: Berlin).
- Hanover, J.W. (1966a). Environmental variation in the monoterpenes of Pinus monticola Dougl. Phytochemistry 5: 713-717.
- Hanover, J.W. (1966b). Genetics of terpenes. I. Gene control of monoterpene levels in Pinus monticola Dougl. Heredity 21: 73-84.
- Harborne, J.B. (Ed.) (1972). "Phytochemical ecology". (Academic Press: London).
- Harborne, J.B. (1977). "Introduction to ecological biochemistry". (Academic Press: London).
- Harborne, J.B. (Ed.) (1978). "Biochemical aspects of plant and animal coevolution". (Academic Press: London).
- Harman, H.H. (1968). "Modern factor analysis". (Univ. of Chicago Press: Chicago).
- Hefendehl, F.W. & M.J. Murray (1972). Changes in monoterpene composition in Mentha aquatica produced by gene substitution. Phytochemistry 11: 189-195.
- Hellyer, R.O., E.V. Lassak, H.H.G. McKern & J.L. Willis (1969). Chemical variation within Eucalyptus dives. Phytochemistry 8: 1513-1514.
- Hickey, M. & C.J. King (1981). "100 families of flowering plants". (Cambridge Univ. Press: Cambridge).
- Hills, H.G., N.H. Williams & C.H. Dodson (1972). Floral fragrances and isolating mechanisms in the genus Catasetum (Orchidaceae). Biotropica 4: 61-76.

- Hill, R.S. (1980). A numerical taxonomic approach to the study of angiosperm leaves. Bot. Gaz. 141: 213-229.
- Hill, R.S. (1981). A stopping rule for partitioning dendrograms. Bot. Gaz. 141: 321-324.
- Hillson, C.J. (1959). Comparative studies of floral morphology of the Labiatae. Amer. J. Bot. 46: 451-459.
- Holman, R.T. & W.H. Heimerman (1973). Identification of components of orchid fragrances by gas chromatography mass spectrometry. Amer. Orchid Soc. Bull. 42: 678-682.
- Huck, R.B. (1981). Evolutionary patterns in Dicerandra (Labiatae). Austral. Syst. Bot. Soc. Newsletter 28: 33-34.
- Hummel, K. & K. Staesche (1962). Die Verbreitung der Haartypen in den natürlichen Verwandtschaftsgruppen. Handbuch der Pflanzenanatomie Band IV, Teil 5: 207-292.
- Hunt, R.S. & E. von Rudloff (1974). Chemosystematic studies in the genus Abies. I. Leaf and twig oil analysis of alpine and balsam firs. Can. J. Bot. 52: 477-487.
- Hutchinson, J. (1969). "Evolution and phylogeny of flowering plants". (Academic Press: London).
- Jacobs, S.W.L. & J. Pickard (1981). "Plants of New South Wales". (D. West, Govt Printer: Sydney).
- Jardine, N. (1969). A logical basis for biological classification. Syst. Zool. 18: 37-52.
- Jardine, N. & R. Sibson (1971). "Mathematical taxonomy". (J. Wiley & Sons: London).

- Jessop, J.P. (1980). Australian Lamiaceae. Austral. Plants 10(83): 299-308.
- Johns, R.K. (1961). "Geology and mineral resources of southern Eyre Peninsula". Department of Mines. Bull. 37 (Govt Printer: Adelaide).
- Johnson, L.A.S. (1976). Problems of species and genera in Eucalyptus (Myrtaceae). Plant Syst. Evol. 125: 155-167.
- Johnson, R.W. (1982). Effect of weighting and the size of the attribute set in numerical classification. Austral. J. Bot. 30: 161-174.
- Junell, S. (1934). Zur Gynäceummorphologie und Systematik der Verbenaceen und Labiaten. Sym. Bot. Upsalienses 4: 1-29.
- Keighery, G.J. (1980). Bird pollination in south Western Australia: A checklist. Plant Syst. Evol. 135: 171-176.
- Kendall, M.G. & A. Stuart (1966). "The advanced theory of statistics". 3 vols. (Griffin Press: London).
- Knoll, F. (1956). "Die Biologie der Blüte". (Springer-Verlag: Berlin).
- Krumbein, W.C. (1962). The computer in geology. Science 136: 1087-1092.
- Labillardière, J.J.H. de (1806). "Novae Hollandiae plantarum specimen". (Huzard: Paris), vol. 2.
- Lance, G.N. & W.T. Williams (1967). A general theory of classificatory sorting strategies. I. Hierarchical systems. Comput. J. 9: 373-380.
- Langenheim, J.H. (1969). Amber: a botanical inquiry. Science 163: 1157-1169.
- Langenheim, J.H. (1981). Variation in terpenoid resins: implications for insect herbivory in the tropics. In "XIII International Botan-

- ical Congress, Abstracts". (Austral. Acad. Sci.: Sydney).
- Lassak, E.V. (1980). New essential oils from the Australian flora. The volatile oils of the genus Prostanthera (Lamiaceae) and of Kippistia suaedifolia (Asteraceae). (Unpubl. talk presented to 8th International Congress of Essential Oils, Cannes, 12-17 October, 1980).
- Laut, P., P.C. Hegligers, G. Keig, E. Löffler, C. Margules, R.M. Scott & M.E. Sullivan (1977a). "Environments of South Australia. Province 2 Murray Mallee". (Land Use Research. C.S.I.R.O.: Canberra).
- Laut, P., P.C. Hegligers, G. Keig, E. Löffler, C. Margules, R.M. Scott & M.E. Sullivan (1977b). "Environments of South Australia. Province 3 Mt Lofty Block". (Land Use Research. C.S.I.R.O.: Canberra).
- Laut, P., P.C. Hegligers, G. Keig, E. Löffler, C. Margules, R.M. Scott & M.E. Sullivan (1977c). "Environments of South Australia. Province 4 Eyre and Yorke Peninsulas". (Land Use Research. C.S.I.R.O.: Canberra).
- Laut, P., P.C. Hegligers, G. Keig, E. Löffler, C. Margules, R.M. Scott & M.E. Sullivan (1977d). "Environmnets of South Australia. Province 7 Western Pastoral". (Land Use Research. C.S.I.R.O.: Canberra).
- Leenhouts, P.W. (1968). A guide to the practice of herbarium taxonomy. Reg. Veg. 58: 1-60.
- Leigh, J., J. Briggs & W. Hartley (1981). "Rare or threatened Australian plants". Austral. Natl Parks & Wildlife Serv. Special Publ. 7. (Commonwealth of Australia: [Canberra]).

- Lindley, J. (1829-1830). "Edward's botanical register: or, ornamental flower-garden and shrubbery". (James Ridgeway: London), vol. 15 [new series vol 2], t. 1282, 1289 [pp. 1 & 2], 1292 [pp. 2 & 3], 1300 [p. 2].
- Maarse, H. & R.E. Kepner (1970). Changes in composition of volatile terpenes in Douglas fir needles during maturation. J. Agric. & Food Chem. 18: 1095-1101.
- Marcus, L.F. & J.H. Vandermeer (1966). Regional trends in geographic variations. Syst. Zool. 15: 1-14.
- Mayr, E. (1969). "Principles of systematic zoology". (McGraw-Hill: New York).
- McGillivray, D.J. (1973). Michel Gandoger's names of Australian plants. Contr. New S. Wales Nat. Herb. 4: 319-365.
- McNeil, J. (1978). Purposeful phenetics. Syst. Zool. 28: 465-482.
- Meissner, L.P. & E.I. Organick (1980). "Fortran 77: featuring structured programming". (Addison-Wesley: Reading, Massachusetts).
- Melchior, H. (1964). Labiatae. In "A. Engler's Syllabus der Pflanzenfamilien". ed. 12 (Borntraeger: Berlin), vol. 2, pp. 438-444.
- Michener, C.D. & R.R. Sokal (1957). A quantitative approach to a problem in classification. Evolution 11: 130-162.
- Mitchell, T.L. (1848). "Journal of an expedition into the interior of tropical Australia, ...". (Longman, Brown, Green & Longmans: London).
- Moore, C. (1893). Labiatae. In "Handbook of the Flora of New South Wales". (C. Potter, Govt Printer: Sydney).

- Mueller, F. von (1855). Definition of rare or hitherto undescribed Australian plants, chiefly collected within the boundaries of the colony of Victoria. Trans. Phil. Soc. Victoria 1: 48.
- Mueller, F. von (1868). Fragmenta phytographiae Australiae. Vol. 6, p. 108. Melbourne.
- Mueller, F. von (1875). Fragmenta phytographiae Australiae. Vol. 9, p. 162. Melbourne.
- Mueller, F. von (1882). "Systematic Census of Australian plants". (M'Carron, Bird & Co. for Victorian Govt.: Melbourne).
- Muller, C.H. (1966). The role of chemical inhibition (allelopathy) in vegetation composition. Bull. Torrey Bot. Club 9: 332-351.
- Munir, A.A. (1978). Taxonomic revision of Chloanthaceae trib. Physopsidaceae. Brunonia 1: 407-692.
- Munir, A.A. (1979). A taxonomic revision of genus Pityrodia (Chloanthaceae). J. Adelaide Bot. Gard. 2: 1-138.
- Nelson, E.C. (1981). Phytogeography of southern Australia. In Keast, A. (Ed.), "Ecological Biogeography of Australia". (W. Junk bv: The Hague).
- Nicholas, H.J. (1973). Terpenes. In Miller, L.P. (Ed.), "Phytochemistry. Volume II Organic metabolites". (Van Nostrand Reinhold: New York), pp. 254-309.
- Nie, N.H., C.H. Hull, J.C. Jenkins, K. Steinbrenner & D.H. Bent (1975). "Statistical Package for Social Sciences". 2nd ed. (McGraw-Hill Book Co.: New York).
- Oh, H.K., T. Sakai, M.B. Jones & W.M. Longhurst (1967). Effects of various essential oils located from Douglas fir needles upon sheep and deer rumen microbial activity. Appl. Microbiol. 15: 777-784.

- Paton, D.C. & H.A. Ford (1977). Pollination by birds of native plants in South Australia. Emu 77: 73-85.
- Penfold, A.R. & J.L. Willis (1961). "The Eucalypts". World Crop Series (Leonard Hill: London, & Interscience Publ.: New York).
- Pijl, L. van der (1972). Functional considerations and observations on the flowers of some Labiatae. Blumea 20: 93-103.
- Porter, D.M., R.W. Kiger & J.E. Monahan (1973). "A guide for contributors to the flora of North America. Part II. An outline and glossary of terms for morphological and habitat description (provisional ed.)". (Smithsonian Institution: Washington, D.C.).
- Powell, R.A. & R.P. Adams (1973). Seasonal variation in the volatile terpenoids of Juniperus scopulorum (Cupressaceae). Amer. J. Bot. 60: 1041-1050.
- Pridham, J.B. (Ed.) (1967). "Terpenoids in plants". (Academic Press: New York).
- Proctor, M. & P. Yeo (1973). "The pollination of flowers". (Collins: London).
- Pyke, G.H. (1980). The foraging behaviour of Australian honeyeaters: a review and some comparisons with hummingbirds. Austral. J. Ecol. 5: 343-369.
- Rao, C.R. (1952). "Advanced statistical methods in biometric research". (J. Wiley & Sons: New York).
- Ratkowsky, D.A. & G.N. Lance (1978). A criterion for determining the number of groups in a classification. Austral. Comput. J. 10: 115-117.

- Raven, P.H. (1972). Why are bird-visited flowers predominately red?
Evolution 26: 674.
- Raven, P.H. (1974). Nomenclature proposals to the Leningrad congress.
I. Proposals for the simplification of infraspecific terminology. Taxon 23: 828-831.
- Reichenbach, H.G.L. (1828). "Conspectus regni vegetabilis". (Cnobloch: Leipzig).
- Roth, I. (1977). Fruits of Angiosperms. Handbuch der Pflanzenanatomie
Band X, Teil 1: 1-675.
- Rudloff, E. von (1967). Chemosystematic studies in the genus Picea
(Pinaceae). I. Introduction. Can. J. Bot. 45: 891-901.
- Rudloff, E. von (1972a). Chemosystematic studies in the genus Pseudotsuga.
I. Leaf oil analysis of the coastal and Rocky Mountain varieties of the Douglas fir. Can. J. Bot. 50: 1025-1040.
- Rudloff, E. von (1972b). Seasonal variation in the composition of the
volatile oil of the leaves, buds, and twigs of white spruce
(Picea glauca). Can. J. Bot. 50: 1595-1603.
- Rudloff, E. von (1973). Geographical variation in the terpene composition
of the leaf oil of Douglas fir. Pure & Applied Chem. 34:
401-410.
- Rudloff, E. von (1975). Volatile leaf oil analysis in chemosystematic
studies of North American conifers. Biochem. Syst. Ecol. 2:
131-167.
- Runeckles, V.C., & T.J. Mabry (Eds) (1973). "Terpenoids. Structure,
biogenetics and distribution". (Academic Press: New York).

- Sandermann, H. (1962). Terpenoids: Structure and distribution. In Florin, M. & O.H.S. Mason (Eds), "Comparative biochemistry, Volume III". (Academic Press: New York), pp. 503-630.
- Sandland, R.L. & P.C. Young (1979). Probabilistic tests and stopping rules associated with hierarchical classification techniques. Austral. J. Ecol. 4: 399-406.
- Schmid, R. (1972). A resolution of the Eugenia-Syzygium controversy (Myrtaceae). Amer. J. Bot. 59: 423-436.
- Schodde, R., B. Glover, F.C. Kinsky, S. Marchant, A.R. McGill & S.A. Parher (1978). Recommended English names for Australian birds. Emu Suppl. 77: 245-307.
- Sharma, M. & V. Singh (1982). Morphology of the gynoecium in Labiatae. Blumea 28: 61-75.
- Smith, P.M. (1976). "The chemotaxonomy of plants". (Edward Arnold: London).
- Sneath, P.H.A. (1957). The application of computers to taxonomy. J. Gen. Microbiol. 17: 201-226.
- Sneath, P.H.A. (1964). Mathematics and classification from Adanson to the present. In Lawrence, G.H. (Ed.), "Adanson: The bicentennial of Michael Adanson's "Familles de Plantes" ". (Univ. of Pittsburgh Press: Pittsburgh), pp. 471-498.
- Sneath, P.H.A. & R.R. Sokal (1973). "Numerical taxonomy". (W.H. Freeman: San Francisco).
- Sokal, R.R. (1965). Statistical methods in systematics. Biol. Rev. 40: 337-391.
- Sokal, R.R. & R.C. Rinkel (1963). Geographic variation of the alate

- Phemphigua populi-transverus in eastern North America. Univ. Kansas Sci. Bull. 44: 467-507.
- Sokal, R.R. & F.J. Rohlf (1969). "Biometry". (W.H. Freeman: San Francisco).
- Sokal, R.R. & P.H.A. Sneath (1963). "Principles of numerical taxonomy". (W.H. Freeman: San Francisco).
- Sondheimen, E. & J.B. Simeone (1970). "Chemical ecology". (Academic Press: New York).
- Southwell, I.A. (1973). Variation in the leaf oil of Eucalyptus punctata. Phytochemistry, 12: 1341-1343.
- Specht, R.L. (1972). "The vegetation of South Australia". (Govt Printer: Adelaide).
- Stace, H.C.T., C.D. Hubble, R. Brewer, K.H. Northcote, J.R. Sleeman, M.J. Mulcahy & E.G. Hallsworth (1968). "A handbook of Australian soils". (Rellim Tech. Publ.: Clenside, South Australia).
- Stafleu, F.A. & R.S. Cowan (1976). Taxonomic literature. 2nd ed. Vol. I: A-G. Reg. Veg. 94: 1-1136.
- Stafleu, F.A. & R.S. Cowan (1979). Taxonomic literature. 2nd ed. Vol. II: H-Le. Reg. Veg. 98: 1-991.
- Stafleu, F.A. & R.S. Cowan (1981). Taxonomic literature. 2nd ed. Vol. III: Lh-O. Reg. Veg. 105: 1-980.
- Stafleu, F.A. et al. (Eds) (1978). International code of botanical nomenclature. Reg. Veg. 97. International Association for Plant Taxonomy, Utrecht.
- Stearn, W.T. (1960). Introduction to R. Brown's 'Prodromus Florae Novae Hollandiae'. In Brown, R. "Prodromus Florae Novae Hollandiae

- et Insulae Van Diemen (1810) and Supplement Primum (1830)".
Facsimile ed. (Engelmann: Weinheim), pp. v-111.
- Stearn, W.T. (1973). "Botanical latin". 2nd ed. (David & Charles:
Newton Abbott, Great Britain).
- Stephenson, W., W.T. Williams & S. Cook (1974). The macrobenthos of
soft bottoms in southern Moreton Bay (south of Peel Island).
Mem. Queensl. Mus. 17: 73-124.
- Stopp, K. (1950a). Karpologische Studien I & II. Abh. Akad. Wiss. Lit.
Mainz, Math.-Nat. Kl. 7: 165-218.
- Stopp, K. (1950b). Karpologische Studien III & IV. Abh. Akad. Wiss. Lit.
Mainz, Math.-Nat. Kl. 17: 495-542.
- Thien, L.B., W.H. Heimermann & R.T. Holman (1975). Floral odors and
quantitative taxonomy of Magnolia and Liriodendron. Taxon
24: 557-568.
- Thorne, R.F. (1976). A phylogenetic classification of the Angiospermae.
In Hecht, M.K., W.C. Steere & B. Wallace (Eds), Evolutionary
Biol. 9: 35-106.
- Toelken, H.R. (1981). The species of Crassula L. in Australia. J.
Adelaide Bot. Gard. 3: 57-90.
- Troll, W. (1964). "Die Infloreszenzen. Typologie und Stellung im Aufbau
des Vegetationskörpers, 1. I Deskriptive Morphologie des Infl-
oreszenzen; II Typologie der Infloreszenzen". (Jena:
Gustav Fischer).
- Troll, W. (1969). "Die Infloreszenzen. Typologie und Stellung im Aufbau
des Vegetationskörpers, 2. III Monotele Synfloreszenzen".
(Jena: Gustav Fischer).

- Turner, B.L. (1970). Molecular approaches to population problems at the infraspecific level. In Harborne, J.B. (Ed.), "Phytochemical phylogeny". (Academic Press: New York), pp. 187-205.
- Tutin, T.G., V.H. Heywood, N.A. Burges, D.H. Valentine, S.M. Walters & D.A. Webb (1964). Introduction. In "Flora Europaea". (Cambridge Univ. Press: Cambridge), vol. 1, p. xx.
- Twidale, C.R. (1968). "Geomorphology". (Nelson: Melbourne).
- Uphof, J.C. Th. (1962). Plant hairs. Handbuch der Pflanzenanatomie Band IV, Teil 5: 1-206.
- Weberling, F. (1965). Typology of inflorescences. J. Linn. Soc. (Bot.) 59: 215-221.
- Weberling, F. (1981). "Morphologie der Blüten und der Blütenstände". (Eugen Ulmer: Stuttgart).
- Weberling, F. (1982). Current problems of modern inflorescence morphology. In Conn, B.J. (Ed.), "Inflorescence morphology". Austral. Syst. Bot. Soc. Newsletter 30: 5-21.
- Weimarck, G. (1972). On "Numerical chemotaxonomy". Taxon 21: 615-619.
- Whiffin, T. (1977). Volatile oils and the study of natural hybridization between Correa aemula and C. reflexa (Rutaceae). Austral. J. Bot. 25: 291-298.
- Whiffin, T. (1978). Geographic variation in tropical tree species. In Tomlinson, P.B. & M.H. Zimmermann (Eds), "Tropical trees as living systems". (Cambridge Univ. Press: Massachusetts), pp. 31-54.
- Whiffin, T. (1981). Analysis of hybridization between Eucalyptus pauciflora Sieber ex Spreng. and E. radiata Sieber ex DC (Myrtaceae).

- Bot. J. Linn. Soc. 83: 237-250.
- Whiffin, T. (1982). Numerical analysis of volatile oil data in systematic studies of Australian rainforest trees. Taxon 31: 204-210.
- Williams, W.T. (1971). Principles of clustering. Annu. Rev. Ecol. Syst. 2: 303-326.
- Williams, W.T. (Ed.) (1976). "Pattern analysis in agricultural sciences". (C.S.I.R.O. Elsevier: Amsterdam).
- Williams, W.T., M.B. Dale & G.N. Lance (1971). Two outstanding ordination problems. Austral. J. Bot. 19: 251-258.
- Williams, W.T. & P. Gillard (1971). Pattern analysis of a grazing experiment. Austral. J. Agric. Res. 22: 245-260.
- Williams, W.T. & W. Stephenson (1973). The analysis of three-dimensional data (sites x species x time) in marine ecology. J. Exp. Mar. Biol. Ecol. 11: 207-227.
- Winkler, H. (1939). Versuch eines "natürlich" Systems der Früchte. Beitr. Biol. Pflanzen 26: 201-220.
- Winkler, H. (1940). Zur Einigung und Weiterführung in der Frage des Fruchtsystems. Beitr. Biol. Pflanzen 27: 92-130.
- Wojciechowska, B. (1958). Taxonomy, morphology and anatomy of fruits and seeds in the genus Salvia L. Monographiae Botanicae 6: 3-56.
- Wojciechowska, B. (1961a). Fruits of the middle european species of the genus Prunella L. (fam. Labiatae), their morphology and anatomy. Monographiae Botanicae 12: 49-88.
- Wojciechowsha, B. (1961b). Fruits of the middle european species of the

- subfamily Stachyoideae (fam. Labiatae). Monographiae Botanicae 12: 89-120.
- Wojciechowska, B. (1966). Morphologie und Anatomie der Früchte und Samen aus der Familie der Labiatae mit besonderer Berücksichtigung der Arzneipflanzen. Monographiae Botanicae 21: 3-244.
- Womble, W.H. (1951). Differential systematics. Science 114: 315-322.
- Zavarin, E., W.B. Critchfield & K. Snajberk (1969). Turpentine composition of Pinus contorta X Pinus banksiana hybrids and hybrid derivatives. Can. J. Bot. 47: 1443-1453.
- Zavarin, E., L. Lawrence & M.C. Thomas (1971). Compositional variation of leaf monoterpenes in Cupressus macrocarpa, C. pygmaea, C. goveniana, C. abramsiana and C. sargentii. Phytochemistry 10: 379-393.
- Zavarin, E. & K. Snajberk (1973). Geographic variability of monoterpenes from cortex of Pseudotsuga menziessii. Pure & Applied Chem. 34: 411-434.

INDEX TO SCIENTIFIC NAMES

In this index orthographic variants are listed in inverted commas. Accepted names are not underlined, synonyms and misapplied names are underlined. The page numbers of major references to a taxon are double underlined, minor references are not underlined, illustrations and distribution maps are indicated by an asterisk.

Index to plant names

Acacia	214, 242
<i>doratoxylon</i>	235
<i>montana</i>	207
<i>sowdenii</i>	207
Ajuga	24
Ajugoideae	2, 24
Banksia	165
Blechnum <i>wattsii</i>	254
Boronia <i>algida</i>	248
Bossiaea <i>foliosa</i>	248
Callitris <i>preissii</i>	198
Calytrix	207
Casuarina	
<i>acutivalvis</i>	242
<i>campestris</i>	242
<i>cristata</i>	235
Codonocarpus <i>cotinifolius</i>	235
Comosperma	165
Chloanthaceae	6

Crassula	19
pedicellosa	20
<u>Cryphia</u> R. Br.	6, 156
<u>microphylla</u> R. Br.	156, 168, 178, 181
<u>serpyllifolia</u> R. Br.	168, 171, 172, 174, 181
Daviesia	165
<u>Depremesnila chrysocalyx</u> F.v. Muell.	6
Dicerandra	28
odoratissima	28
Dicksonia antarctica	254
Dodonaea viscosa	207
Eichlerago Carrick	1
Eremophila	24, 214
interstans	207
Eriostemon difformis	235
Eucalyptus	109, 242
delegatensis	248
incrassata	194, 198
morrisii	235
niphophila	248
obliqua	254
oleosa	194
pauciflora	248
perriniana	248
regnans	254
socialis	194, 198
stellulata	248
viminalis	248, 254
viridis	235

Euphrasia collina	
ssp. tetragona	108
Geniostoma	29
Grevillea	194
Hakea	194
Hemiandra R. Br.	1
Hemigenia R. Br.	1
Isopogon	207
Ixodia achillaeoides	108
<u>Klanderia</u> F.v. Muell.	6
<u>chlorantha</u> F.v. Muell.	162
Labiatae	1, 2, 12, 24-29, 151
subfamily Ajugoideae	2, 24
subfamily Prostantheroideae	1, 2, 15, 24, 29
subfamily Rosmarinoideae	2
tribe Prostanthereae	2
Lamiales	2
Lavandula officinalis	13
Leptospermum	165
Loganiaceae	29
Melaleuca	194, 214
lanceolata	198
uncinata	198, 207
Microcorys R. Br.	1
Myrtaceae	19, 61
Oxylobium alpestre	248
Pinus	152
Pittosporaceae	61
Pittosporum	194
rhombifolium	61
Pityrodia chrysocalyx (F.v. Muell.) Gardner	6
Prostanthera Labill.	1, 4-6, 15, 19, 26-29,
.....	129, 151-153
sect. <u>Cryphia</u> (R. Br.) Briq.	5, 156
sect. <u>Depremesnilia</u> Briq.	6
sect. 'Depresmenilia'	6
sect. <u>Euprostanthera</u>	5, 6, 154

sect. <i>Klanderia</i> (F.v. Muell.) Benth.	2, 3, 5, 11, 14, 15,
.....	19, 20, 22, 25-33, 37, 109, 112,
.....	152, <u>156</u> , <u>157</u> , 194, 250
sect. <i>Prostanthera</i>	3-6, 15, 20, 22, 24, 27,
.....	28, 31, 33, <u>154</u> , 182, 257
series <i>Convexae</i> Benth.	4, 5
series <i>Racemosae</i> Benth.	4, 5
series <i>Subconcaevae</i> Benth.	4, 5, 152

Prostanthera

<u>arenicola</u> S. Moore	168, 180
<u>aspalathoides</u> A. Cunn. ex Benth.	2, 3, 10, 11, 14, 22,
.....	23, 26, 27, 30, 33, 38, 40, 52, 53,
.....	62, <u>66-70</u> , <u>85-97</u> , 106, 109, 113,
.....	125, 126, <u>131-151</u> , 157, 158*, 174, 182,
.....	<u>196-198</u> , 199*, 200*, 201, 202 203*, 207, 257
<u>baxteri</u> A. Cunn.	152
<u>behriana</u> Schltr.	27, 33, 152
<u>caerula</u> R. Br.	15
<u>caleyi</u> Benth.	174, 257
' <u>calicina</u> '	191
<u>calycina</u> F.v. Muell. ex Benth. 2, 3, 13, 20, 53, 62, <u>70-76</u> , <u>97-112</u> ,	
.....	125, 157, <u>191</u> , <u>192</u> , 193*, <u>194</u> , <u>195</u>
<u>chlorantha</u> (F.v. Muell.) Benth.	11, 13, 14, 20, 22, 23, 52,
.....	109, 156, 157, <u>162</u> , <u>163</u> ,
.....	164*, <u>165</u> , <u>166</u> , 167*, 257
<u>chrysocalyx</u> (F.v. Muell.) Briq.	6
<u>coccinea</u> F.v. Muell.	168, 172, 174, 179, 184, 196
<u>cuneata</u> Benth.	15
<u>eckersleyana</u> F.v. Muell.	15, 27
<u>ericalyx</u> Gand.	196
<u>florifera</u> Conn	14, 20, 22, 23, 26, 33, 52,
.....	62, 157, 201, <u>204</u> , 205*,
.....	<u>206-209</u> , 210*
<u>grylloana</u> F.v. Muell.	14, 23, 26, 52, 157,
.....	<u>241</u> , <u>242</u> , 243*, <u>244</u> , 245*
<u>incurvata</u> Conn	13, 14, 26, <u>76-82</u> , <u>112-125</u> ,
.....	157, <u>216-218</u> , 219*, <u>220</u> ,
.....	221*, 225, 232

- laricoides Conn 2, 3, 13, 14, 23, 53, 76-82,
..... 112-126, 157, 190, 218,
..... 221*, 225, 229, 230*, 231, 232
- lasianthos Labill. 1, 5, 15, 17*, 18*, 27, 31, 153, 155*
- leichhardtii Benth. 33, 233
- lepidota C.T. White 233
- microphylla A. Cunn. ex Benth. ... 26, 27, 33, 38, 40, 53, 70-76,
..... 97-112, 113, 125, 168, 174,
..... 178, 179, 182, 184
forma aeruginosa J.H. Willis 168, 180, 184
- monticola Conn 11, 14, 20, 22, 26, 31, 52, 152,
..... 157, 246-248, 249*, 250, 251, 252*, 256
- nivea A. Cunn. ex Benth. 152
- ovalifolia R.Br. 15, 27, 153
- patens Conn 11, 13, 14, 20, 23, 76-82,
..... 112-125, 157, 187, 188*,
..... 189, 190, 221*, 232
- patula Gand. 196
- pedicellata Conn 12-14, 76-82, 112-125,
..... 157, 211, 212*, 213-215, 221*, 225, 228
- ringens Benth. 14, 20, 22, 33, 52, 157,
..... 233-235, 236*, 237, 238*, 239, 240
- rotundifolia R. Br. 15, 17*, 19, 27
- saxicola R. Br. 152
- scutellarioides (R. Br.) Briq. 182
- semiteres Conn 12-14, 76-82, 112-125, 157,
..... 214, 218, 221*, 222, 223, 224*, 225-228
ssp. semiteres 78, 157, 221*, 225-227, 228
ssp. intricata Conn .. 78, 157, 214, 221*, 224*, 225, 227, 228
- serpyllifolia (R. Br.) Briq. ... 2, 3, 11, 29, 40, 53, 62, 70-76,
..... 97-112, 125, 126, 150, 156, 157,
..... 168-172, 173*, 174, 175, 176*,
..... 177-182, 183*, 184-186, 190, 194, 201
ssp. serpyllifolia 14, 157, 171, 172, 173*, 174, 175,
..... 176*, 177, 178, 181, 201
ssp. microphylla (R. Br.) Conn 13, 14, 21, 23, 26, 27, 33, 41,
..... 112, 157, 165, 171 177, 178-182,
..... 183*, 184-186, 194, 201
- spinosa F.v. Muell. 15, 31, 33

striatiflora F.v. Muell.	27, 31, 235
stricta R.T. Baker	15
suborbicularis C.T. White & Francis	152
teretifolia Maiden & Betche	15
walteri F.v. Muell.	11, 14, 20, 22, 26, 29, 31, 32,
.....	52, 152, 157, 250, 252*, <u>253</u> , <u>254</u> , 255*, <u>256</u>
wilkeana F.v. Muell.	27
Prostanthereae	2
Prostantheroideae	1, 2, 15, 24, 29
Pultenaea juniperina	254
Rosmarinoideae	2
Salvia patens	19
Santalum acuminatum	194
Sapindaceae	207
Scropulariaceae	108
Spyridium	194
Teucrium fruticans	19
Triodia	184, 198, 207
Tristania conferta	61
Verbenaceae	2
Westringia J.E. Smith	1, 19
cephalantha F.v. Muell.	19
fructicosa (Willd.)Druce	1
Wrixonia F.v. Muell.	1, 190

Index to bird names

Acanthorhynchus superciliosus	26
Anthochaera carunculata	27
Lichenostomus	
cratitius	26
leucotis	26
virescens	26
Lichmera indistincta	26
Manorina melanotis	27
Phylidonyris	
albifrons	26
melanops	26
pyrrhoptera	26