

RC  
620.5  
H99.

# Hysteresis

1957

ADELAIDE UNIVERSITY  
ENGINEERING SOCIETY

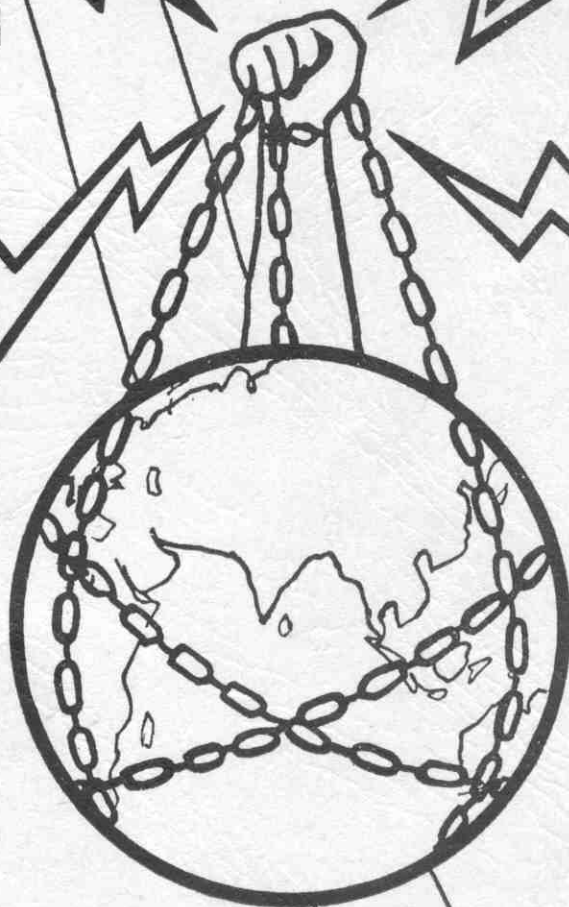

# ***HYSTERESIS***

## ***1957***



*Editor:*

F. J. W. SYMONS.

*Assistant Editor:*

OH, K. Y.

*Business and Advertising Managers:*

R. L. BAMFORD.

J. F. BATEUP.

*Photographer:*

J. REINFELDS.

*Official Journal of the Adelaide University Engineering Society.  
University of Adelaide,  
South Australia.*



**MAGAZINE COMMITTEE**  
 R. L. Bamford, F. J. W. Symons, Oh, K. Y., J. F. Bateup.

# CONTENTS

	Page		Page
Editorial -- -- -- -- --	3	Whither Automation? (L. T. Schneider) --	41
Dean's Page -- -- -- -- --	5	Engineering Faculty Bureau (K. R. Weller)	44
Modern Wire Ropes (J. F. H. Westley) --	7	The Bhakra-Nangal Project (I. J. Vijh) --	46
Impressions (Oh, K. Y.) -- -- -- --	13	Throgmorton is Back -- -- -- --	47
Eric (W. N. Holmes) -- -- -- --	14	Mech. Department Projects -- -- --	49
White or Right? (Ian Haig) -- -- --	15	Petrochemicals (G. N. Walton) -- --	52
Civil Engineering Activities -- -- --	17	Tin Dredging in Malaya (K. Kandiah) --	55
The Sentimental N.S.T. -- -- -- --	19	Life at an Oil Refinery ("Globule") --	57
A.U.E.S. Committee -- -- -- --	20	Inter-Faculty Sport -- -- -- --	59
How Many Beans Make Five? -- -- --	22	Control of Dampers for Vehicle Suspension	
The Secretary's Report -- -- -- --	24	(P. L. Goodale) -- -- -- --	60
The Analogue Computer (L. W. A. Glasson)	26	Frustration (K. R. Weller) -- -- --	64
The Institution of Engineers -- -- --	29	Electrical Research -- -- -- --	65
A Day at Survey Camp (S. Y. Tay) -- --	31	S.C.I.I.A.E.S. -- -- -- --	67
Uranium (R. G. Staker) -- -- -- --	33	Are You Educated? -- -- -- --	69
The Common Lecturer (A. J. Dawson) --	37	Precision Machine Tools (R. B. Smith) --	71
Met. and Chem. Doings -- -- -- --	39	Shame on Engineers (G. Meija) -- --	72

# EDITORIAL

We have chosen to enter the Engineering Profession. We are studying at the University so that we can qualify for that entrance.

What really is a professional engineer? What does he actually do? What are his obligations to society? What qualities and qualifications does he need to do his work properly? The questions are all very relevant to the engineering student, and he should try to find the answers to them very early in his course.

It is perfectly obvious that the mere possession of a degree of Bachelor of Engineering does not make a man a professional engineer. We will be failing in our duty if we leave the University with just a degree. The University is the training ground where we are preparing ourselves to take a responsible position in the community. Just how well and fully we are prepared lies solely in our own hands.

Engineers now no longer are confined to design and drawing office work. They are given more general administrative and executive functions in industry. Broadly, we shall be dealing with men and materials. We spend five years doing a B.E., learning about materials and machines. We are not taught anything about men. How much and what we learn about men is purely up to us.

As far as the B.E. work is concerned, the student should emphasise the understanding of basic principles, ideas and theories, and should try to develop skill in the use of this understanding in solving problems and situations which are new to him.

This technical knowledge, and the skill in applying it, will be nullified if the engineer does not understand those who work with and under him. The engineer must learn to understand and appreciate men. With our specialised knowledge we have a deep obligation to contribute our best to the community. Our sense of values will have to be changed, and an emphasis placed on mutual service. It is true that in our profession the social problems far outweigh the technical ones, and are more important. The engineering student, as a future leader of men, must take a genuine interest in the men he will control and their welfare. He must learn more about people.

At the University we are in a unique environment. Never again will we have an opportunity like this to learn about men. Here we can meet and talk to all kinds of people, with all kinds of ideas, backgrounds, and personalities. To ensure successful dealing with people, a great deal of experience is essential. It is best and easiest to learn whilst young, among our friends, when and where mistakes do not matter so much. We should join as many clubs and societies as possible, and enter fully into the true University life.

We have the intelligence and will to overcome our technical problems. We should also have the intelligence and will to overcome the social problems of the community.

As students, we should persevere with all subjects, no matter how useless they may appear, write thorough practical reports, take a lively interest in the humanities, and participate fully in student affairs. Thus we may be able to transform our knowledge into wisdom, and our learning into culture.

Our first and foremost study, then, is our fellow man.



**FOR A  
SOLID  
FUTURE**

*Chrysler  
can open  
the door  
to big  
opportunities  
for you*

**ENGINEERING  
GRADUATES**  
SHOULD LINK UP  
WITH  
**CHRYSLER**  
AUSTRALIA  
LIMITED

*You owe it  
to yourself  
to find out  
what Chrysler  
has to offer*



**BE TRAINED FOR AN EXECUTIVE POSITION WITH  
AN ORGANISATION THAT'S "GOING PLACES"**

Chrysler is taking another big step forward in its Australian expansion and is now seeking its executives of the future. The Company will train suitable young men for future high positions in Product Design, Product Engineering, Manufacturing, Supply, Personnel and other departments.

**DETAILS REGARDING TRAINING, SALARY, ETC.,  
AVAILABLE ON APPLICATION**

**THESE ARE THE QUALIFICATIONS YOU NEED !**

Not more than 25 years of age (Ex-servicemen 30 years). Hold, or reasonably expect to hold by the end of this year, an approved University degree in Engineering, Science, Economics or Diploma from recognised Technical College or similar institution.

**HERE'S WHAT TO DO**

Write straight away to The Personnel Manager, Chrysler Australia Limited, Keswick, South Australia. Give fullest details of courses undertaken, where educated, experience (vocational and post graduate if any), etc.

**CHRYSLER AUSTRALIA LIMITED, KESWICK, S.A. - - - PHONE LF 1561**

# THE DEAN'S PAGE

A new phase of engineering education in this State commenced some ten years or so ago, when several new chairs were established, and new buildings and facilities were planned to bring within the University most of the professional engineering courses previously provided by the School of Mines. This decade has been associated with much change and growth in staff, laboratory facilities, and research activities in the Faculty of Engineering. Another milestone has just been reached with the establishment of the Faculty of Technology—a cooperative move by these two educational institutions.

It is perhaps permissible (for the middle-aged) or even desirable, in order to maintain a proper perspective, to look back occasionally to note a sequence of events, and to observe the paths of progress. As our world is, technologically speaking, "One World," with a common language in knowledge, ideas, and aims, it will be a world scene, and not a purely local one, in which our minds must browse. In this broad arena much can now happen, even in one short decade. With the geometric progression of our age of technology, the multitude of building stones provided by research workers in the basic sciences and mathematics are eagerly grasped by the practitioners of the "useful arts," and engineered in ever new and extending fields of endeavor. As philosopher Whitehead has remarked, the greatest invention of the nineteenth century has been the invention of the method of invention.

One might select a few examples of a more spectacular kind from among the many—air transport, nuclear power, cybernetics.

The growth of human locomotion from its pedestrian 4 m.p.h. for over a million years to an equestrian pace for many more millennia has, during the last 50 years, taken wings beyond the speed of sound. A graph of speed against time would present a crude picture of the rate of advance of technology with the concurrent raising of productivity, income, and material standards in the industrially developed nations.

Nuclear power as a practical proposition has depended for its realisation on knowledge from many independent lines of research—50 years of study of radio-activity; 20 years of development of high-voltage machines; the equivalence of mass and energy announced by Einstein in 1905 as part of his theory of relativity; several decades of study of cosmic rays; 50 years of development of electronics; the whole modern art of chemical separation; the science of radiology; the most modern refinements of metallurgy and

chemistry. The practical realisation of nuclear power generation has called upon the highest skills in engineering design and instrumentation. When all the associated possibilities in the use of radioactive isotopes and of modification and control of properties of materials by neutron bombardment are realised, we have an exciting picture.

Another profoundly important development born of the labor of mathematicians and physicists and nurtured by a mixed band of scientists and engineers has been termed "cybernetics, or control by closed-loop feedback mechanisms. Although automatic control was used in a simple form by James Watt for speed governing in the early 19th century, and many food and other process industries have used elementary closed loop systems during the latter half of the 19th century, the major developments in theory and practice have occurred during the last two decades. The results may be seen in such refinements as the automatic piloting of aircraft, and anti-roll stabilisation of ships, the automatic regulation of complex power plant and industrial processes (including nuclear power), and as automation in some of the fabrication industries. The rapid development of reliable electronic analogue and digital computing devices is extending the effectiveness of control systems, as well as providing a range of computing aids for the solution of otherwise impossibly tedious or complex problems in most branches of science and engineering (and economics). The immense actual and potential contribution of such developments in computation and control will accelerate the evolution initiated by the introduction of mechanical power, and of the ubiquitous machine in all its forms. This power-machine-control chain is a vital one in the rise of productivity, with all its attendant freeing of people from heavy labor, drudgery, and routine, and its provision of more leisure and luxury and higher education. The broader study of cybernetics, including information theory, involves mathematicians, physicists, biologists, psychologists, economists, industrialists, and engineers—wherever questions of analysis or control of the behaviour of dynamic systems is concerned.

These three fields associated with intense effort and development cover only a small sector of the expanding full-circle of human activity associated with the study and control of our environment, and utilisation of natural resources.

Although man cannot live by "bread" alone, yet man must have his "bread," and naturally wants it more abundantly. This fascinating pre-

occupation of the scientist with his environment does, of course, satisfy an inborn curiosity and joy in discovery, "the supreme delight of extending the realm of law and order ever farther towards the unattainable goals of the infinitely great and the infinitely small, between which our little race of life is run" (T. H. Huxley). The engineer's urge to conquer his environment, and to create things of utility and (one hopes) of beauty, also provides great personal satisfactions—joining with the Creator, who is still creating our expanding universe.

But a more pressing factor than personal satisfactions of scientist or engineer in his work has arisen in recent times. Medical science, aided by a multitude of other contributions, has spectacularly improved the health and extended the longevity of human beings, with the resulting sharp rise in world population. The making of our world into a "neighborhood," largely through developments in transport and communications, has thrown into stark relief the amazing co-existence on our planet of nomadic stone-age man and all stages of agrarian, handicraft, and industrial economies—likewise the co-existence of autocracy and democracy—in fact, the phylogenesis of human history. The living standards of perhaps nine-tenths of the world's peoples might be considered to be sub-standard. The new almost universal phase of nationalism, even among small regional groups, and the paternal attitude of U.N., will ensure a demand for reasonable and ever-improving standards. Thus the call to the scientist and the technologist is now one of service to the world community, to make their contribution to sufficiency, security, and the "luxuries" one has come to expect. No one doubts their potential ability to accomplish this purpose. The enormous responsibility for the maintenance of world stability to allow such a constructive programme to proceed rests much with statesmen and economists, although it is the concern of all.

The resulting recent phenomenon of a world hunger for increasing higher education, and in particular for more scientists and technologists, has been highlighted by the Russian approach to this problem. The spirit of competition has served to accelerate the vast programmes being planned by most nations. Efforts are being made to reduce the wastage of human talent by providing incentives for young people to further develop their latent abilities. National Productivity Councils are being set up to ensure higher human efficiency and optimum use of power and material sources. Enlightened labor is being encouraged to co-operate with more scientific and humanised management.

How are these changes affecting our profession? There has been a marked change in recent

times from a preponderance of individual consultants and small firms to large organisations, with teams of specialists in functional grouping. No longer can one man compass the range of knowledge in any branch of engineering, as in grandfather's day. There has been a segregation of type of activity for each man, as well as specialisation of field of activity, e.g., segregation of research, development, design, production planning, organisation, and management. Research alone is now a major activity, involving large numbers of graduate engineers in full-time collaboration with scientists and mathematicians—often in large Government research institutions if it is costly or of national interest. Professional engineers now provide the greatest single source of potential top-level management in private and Governmental engineering type enterprises.

What are Universities doing to assist in meeting these needs? There has been the steady growth of new major specialities—for example, mechanical engineering has been a parent to degree courses in aeronautical, marine, agricultural, nuclear power, and production engineering in some universities. Within major branches, specialist options are becoming more common in the final years. There is a growing effort to broaden the general educational content of courses by the introduction of "Humanities" subjects. Potential employers, now very graduate conscious, are co-operating more effectively in providing cadetships, suitable vacation experience, and graduate apprenticeships. Post-graduate extension lecture courses and post-graduate research training leading to higher degrees are a normal and expanding activity of all universities.

May I conclude by referring to the important and able address to I.Mech.E. London (Engineering, May 4, 1956) by a distinguished "outsider" from Oxford, Sir M. Bowra. He emphasised that the contribution of engineering to the technological age has been evolution, not revolution. It has been a constructive contribution, and a stabilising influence in that it is gradually helping to remove economic causes of discontents between classes and countries. Its stabilising influence in a cultural sense lies in its emphasis on the rational approach to all problems, and the confidence in solution by painstaking study and experiment. He also sees a possible solution to the war mentality in providing constructive adventures associated with the conquest of the air, of space, of desert and polar regions, of famine, drought and disease, and so on.

Unlike Alexander the Great, the graduates of our universities cannot complain that there are no more worlds to conquer. Progress proceeds apace, but the vista ever widens. The world awaits you!

H. H. DAVIS.

# MODERN METHODS OF TESTING WIRE ROPES

By J. F. H. WESTLEY.

*The development of non-destructive tests in modern industry is most important.*

The making of bigger and better machines in all phases of the engineering industry has in general led to the use of higher speeds and higher stresses.

In consequence, better materials and manufacturing techniques are required. Manufacturers had to be sure that the part would develop its full design strength. A part might look perfect from all outside appearances, and still conceal some internal flaw that would impair its performance. Some method of testing these parts had to be developed, so that all individual parts could be guaranteed. This led to the use of non-destructive methods of testing.

X-rays provide us with an easy way to test metal parts for flaws, and are used extensively in the mining industry. Vickers and Brinell hardness tests are used to get some idea of the physical properties of the material in the part. Cracks can be detected in castings by immersing them in a solution of a fluorescent substance. When removed from this solution the excess can be washed off, and the part subjected to examination under ultra-violet light, whereupon any cracks show up as bright lines. Ferrous metals may be tested by their magnetic properties, which are greatly affected by local stress conditions, variations in composition, cracks, and changes in cross section or thickness. All the foregoing tests are actually used to control the manufacture of articles in industry. It was inevitable that someone would eventually try to apply these ideas to the examination of mine hoist ropes.

The present methods of mine rope inspection and testing are stated in the various State Mine Inspection Acts. Generally speaking, they require a daily visual inspection for broken wires, and periodic detailed inspections every 100 feet along the length of the rope. Every six months the Act requires a length to be cut from the rope at the cage end, and that this length of rope be tested to find its tensile strength.

It is obvious that certain parts of a hoist rope are more severely stressed than others. Points which come into this category are:

- 1.—The length of rope on the sheave when skip loading takes place.
- 2.—Cross-over points on the winder drum.
- 3.—The bottom layers on the drum tend to become squashed.

Removing a length of rope from the capel end merely shifts these points of higher stress to a fresh portion of the rope. It is very doubtful whether the length cut from the rope has been as badly stressed as certain other portions of it, and hence the tensile strength obtained for it cannot be said to be indicative of the strength remaining in the rope.

Broken wires usually occur in the outer strands of the rope. The outside wires are abraded in normal use, some to a greater extent than others, and if the cross-section of a wire becomes too small it may break. Destructive tests have shown that in the case of a single broken wire in a single strand, or even a single broken wire in several strands at the same point, does not greatly affect the strength of the rope. The reduction in strength is only that due to the reduction in steel area, and as such amounts to much less than 1 per cent. of the total strength in an average rope. On the other hand, a group of wires broken in a single strand does reduce the strength greatly. These broken wires are usually easy to see from a visual examination. External surface wear can also be seen by visual examination, although no accurate estimate of its extent can be obtained in this way. Internal corrosion and internal wear, however, are things which, as a general rule, cannot be seen from an external examination, no matter how thorough it might be.

One of the main disadvantages of the regulation method of testing is that it is possible for a rope to be discarded not because it is worn out, but because it has become too short to be of any use. The cost of new hoist ropes is considerable—in fact, for a large mine operating at depth in the range 3,000–4,000 feet, a single rope will cost well over £4,500. The cost of changing it can also be considerable, particularly if replacement disrupts production. When human life is at stake no chances must be taken, but no mine wants to



# SERVICE



SERVICE CONSISTS IN GIVING the customer more than the strict letter of the contract calls for. It grows out of thoughtful consideration for his convenience; a sincere desire to make his purchases a source of complete satisfaction.

A SINGLE TRANSACTION may be swung by price alone, but lasting business relationships are never built on a cut-price basis; they are made by giving the customer something more than he bargained for. Lasting relationships, founded on confidence, cemented by goodwill, are the only kind profitable to both parties.



*You are invited to consult*

## THE GRIFFIN PRESS

(DIVISION OF ADVERTISER NEWSPAPERS LIMITED)

MARLBOROUGH PLACE, ADELAIDE • TELEPHONE LA 0421

throw away £5,000 if it is not absolutely necessary. The ultimate aim of non-destructive testing is to be able to assess the remaining strength in a rope at any place along its length, to predict the point of failure, and to calculate a factor of safety at this point, with a view to discarding the rope when the factor of safety drops below a certain value. This will give the complete picture of a rope's condition, and not just the condition of a part of it. This has not yet been achieved, but will be possible with perseverance and systematic research.

Tests carried out in Australia and overseas prove that portions of a rope showing wear, corrosion, and broken wires, as well as cross-over points and kinks in the rope, have different magnetic properties, and can be detected by means of suitable magnetic equipment. In a test carried out on a rope a continuous magnetic record can be made over the whole length of the rope. This record will contain certain anomalies which can be directly attributed to cross-over points, etc. However, after this there will always remain some anomalies which cannot be accounted for. It seems reasonable to assume that there must be a reason for their existence—surely they cannot just appear of their own accord. In order to explain these anomalies it will be necessary to make further investigations. Mr. Morgan, Reader in Mining Engineering, University of Adelaide, has shown us that a cage travelling in a shaft may be subjected to longitudinal and transverse accelerations of about 3g. in both positive and negative directions without causing great discomfort to the passengers, so even comparatively good shaft guides may cause fairly large spurious shocks to be transmitted to the cage and then to the rope. The resulting stresses in the rope due to shocks caused by acceleration could be the cause of faults developing in all manner of places along the rope. Also small trickles of mine water in the shaft could be the cause of a corroded patch of cable. There is very little evidence at present to back up these two points, but it does indicate a line of action that could be taken up if the magnetic methods of testing are successful, and are adopted by the mining companies.

From what I said earlier, one might be led to believe that this idea is entirely new. However, that is not true. Experiments are known to have been carried out as far back as 1905. From here on the discussion will be confined to the development of these magnetic methods of testing, and to the equipment used in making the tests.

At this stage I feel that it would be a good idea to enumerate the desirable qualities that such a testing machine should have in order to be reasonably effective. From the time angle, it would be desirable to carry out the test at a rope speed of at least 300–500 feet per minute. The instrument should be able to detect broken wires not only on the outside of the cable, where

they are most likely to occur, but also any that might exist inside the rope in a hidden layer. The instrument must also be made to detect any changes in the gross steel area of the cable, due to wear on the external wires and, probably most important of all, it should be capable of indicating places where both internal wear and corrosion exist.

In 1929 T. F. Wall had a paper published by the Institution of Electrical Engineers giving details of experiments carried out using D.C. and very low frequencies of alternating current. A magnetic flux was induced into the rope by means of an iron yoke wound with a magnetising coil. The rope was surrounded by another coil, which picked up any magnetic flux variations resulting from the flaw. He used very high flux densities, and if the frequency rose even to 50 cycles, he had to be very careful not to remove the temper from the cable, because of the large quantities of heat produced in it from eddy current losses. The instrument was very sensitive as a broken wire detector, and could detect a flaw amounting to as little as 1 per cent. of the total cross-section. The Carlton Main Colliery Co used Dr. Wall's machine for some time. However, because of its very slow speed, which was less than 60 feet per minute, some person with a sense of humor commented that the colliery had to decide whether to use Dr. Wall's machine or raise coal. Since Dr. Wall's efforts in 1929, little information appears to have been published.

Immediately after a disaster in 1945, in which 16 lives were lost, the Mines Department of Nova Scotia decided to investigate the available methods for testing mine ropes non-destructively. Little success had been obtained using the principles described later, and so they decided to investigate an entirely new idea. Previous tests had used high flux densities and low frequencies, whereas their new idea was to use very low flux densities and higher frequencies. The equipment that eventually came forth from these tests, with the help of the General Engineering Co., was of the modified Cyclograph type.

The main disadvantages of the original Cyclograph machine are its failure to give good indications for internal corrosion, and the dynamometer readings are a necessity for any interpretation. These factors may have been overcome by now. The South Africans tried this method, and they claim that a large number of apparent defects are due not so much to the stress conditions as they are to the strands bedding into the sizal core. A load on the rope causes the wires in the strands to be pressed closer together, thus increasing the eddy current losses, and hence giving a lower Cyclograph reading. Another disadvantage is that the instrument cannot distinguish between the different types of faults, corrosion, broken wires, or wear.

The equipment that has been constructed here in Adelaide is very similar to that used by the Union Corporation in South Africa, and is com-



# **E. ESDAILE & SONS PTY. LTD.**

**103-105 Waymouth Street, Adelaide**

LA 6346-7

- SCIENTIFIC
- INDUSTRIAL
- SURVEYING
- OPTICAL
- NAUTICAL
- METEOROLOGICAL
- DRAWING OFFICE

**A BRIEF SELECTION OF INSTRUMENTS ALWAYS IN STOCK:—**

ALIDADES	MICROSCOPES
ANEMOMETERS	MICROMETERS
AIRFLOW METERS	NAUTICAL COMPASSES
BAND CHAINS	PRISMATIC COMPASSES
BAROMETERS	POLARIMETERS
BAROGRAPHS	PYROMETERS
BINOCULARS	PRESSURE GAUGES
CLOCKS	REFRACTOMETERS
COUNTERS	STEEL TAPES
CAMERAS	STOP WATCHES
CONTROLLERS	SEXTANTS
DRAFTING MACHINES	SLIDE RULES
DIAL INDICATORS	SPECTROSCOPES
DRAWING INSTRUMENTS	THEODOLITES
DIAPHRAGM VALVES	THERMOMETERS
HYGROMETERS	TELESCOPES
LEVELS	THERMOGRAPHS
MANOMETERS	TACHOMETERS

**WE HAVE PRECISION MACHINES FOR  
DIVIDING AND ENGRAVING**

**You are cordially invited to visit our new Waymouth Street Showrooms to  
discuss your instrument requirements**

pletely different to any of the foregoing. The machine operates at very low field strengths, and hence low values of permeability for the steel. This enables the machine to get much better penetration into the inner wires of the cable.

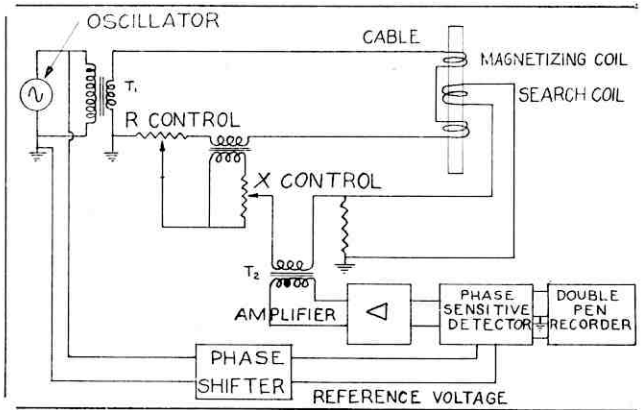

The operation of the machine in a simplified form is as follows. (See figure.) The output from a beat frequency oscillator is fed into a step-down transformer which then supplies a current to the magnetising coils surrounding the cable. A search-coil surrounds the cable, and hence the cable becomes the core of another transformer. The magnitude of any voltage induced in the search-coil depends on the steel area in the cable, and the stress condition of the steel. The phase angle between the magnetising current and search-coil voltage depends on the eddy current losses. If a rope is corroded the individual wires are insulated from one another, and eddy current losses are low. If the wires are bright, then the

rope acts more like a solid piece of steel, and eddy current losses are high.

With a good piece of rope in the coil, the search-coil voltage is balanced by means of resistive and a reactive voltage components from the R and X controls respectively. Any change in the rope properties will now cause an out-of-balance voltage to be produced in the secondary T2. This signal is amplified and detected by means of two phase sensitive detectors. The outputs from the phase sensitive detectors are fed to the pens of a double pen recorder. The reference voltages for the phase sensitive detectors are 90 degrees out of phase, and are arranged so that one needle records search-coil voltage amplitude changes, and the other record search-coil voltage phase changes.

Generally speaking, internal corrosion shows up as a phase angle change, rope cross-section wear gives a decrease in voltage amplitude, and localised points having high stress give an increase in the voltage amplitude.

It is desirable to take dynamometer reading if possible, because this gives added information, but it is not a necessity. Theoretically, this machine has the advantage that it can distinguish between several types of faults. In practice this cannot be done perfectly, but quite encouraging results can be obtained with regularity. More research should increase reliability.

A considerable amount of work has been done in Canada and South Africa, and a certain amount of success has been obtained. However, much work remains yet to be done before the results can be fully accepted. I feel that a little sympathetic enthusiasm and action on the part of those who would benefit from its success would be well worth while.

## WAKE UP, CANBERRA!

The following was disclosed by Mr. N. G. Young, General Treasurer of the Association of Professional Engineers.

There are only 15,000 employee professional engineers in the Commonwealth.

At the present time Australia is training only nine students to be professional engineers for 100,000 of population. Compare this with 25 per 100,000 in Russia, and 14 per 100,000 in U.S.A. Both Russia and U.S.A. plan an increase in training of 50 per cent. and 100 per cent. respectively in the next few years.

Only 900 students are graduating each year at Australian Universities and Technical Colleges in the various branches of engineering. There is an urgent need to increase this yearly figure to at least 2,000 in the shortest possible time.

**Australia's progress, production, and prosperity are being gravely retarded by the lack of professional engineers.** Only the most drastic steps can effectively overcome this shortage. The

professional engineer is the key person in all branches of technology.

The major disabilities that must be overcome in a drive to increase the intake of engineering students are lack of adequate training facilities and lack of suitable students offering for courses. Greater financial assistance has to be given to Universities and technical colleges, and the status of the professional engineer must be rapidly improved.

Mr. Young added: "We could well afford to take a leaf from Russia's book, where there appears to be no lack of funds for technical training, and where the professional engineer is highly paid, and enjoys very high prestige."

Two gangsters were escorting a rival across a lonely field on a dark, stormy night.

"What rats you guys are," he groaned, "making a guy walk through rain like this."

"What's eatin' you?" was the reply. "We gotta walk back."

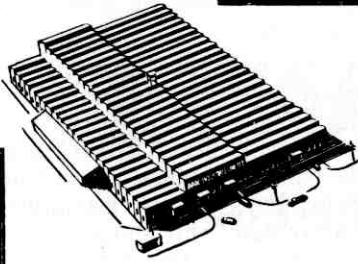

# WHEREVER THERE'S WORK TO BE DONE!

In factories, warehouses, stores, service stations, in fact business premises of all kinds, it's there you'll find quality engineered Apac Products. For Apac-built Automotive Jacks, Lemcol Materials Handling Equipment and Alemite Lubrication Equipment are products specially designed with a dual purpose in view, to magnify man's strength and capacity, and to expedite his efforts with maximum efficiency.

## Lemcol QUALITY ENGINEERED MATERIALS HANDLING EQUIPMENT . . .

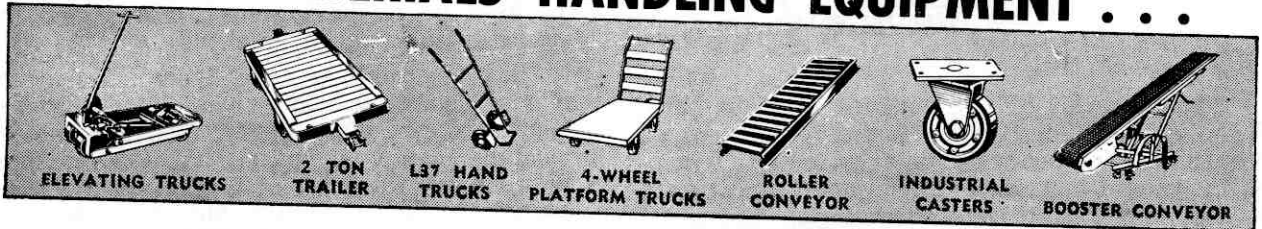

ELEVATING TRUCKS

2 TON TRAILER

L37 HAND TRUCKS

4-WHEEL PLATFORM TRUCKS

ROLLER CONVEYOR

INDUSTRIAL CASTERS

BOOSTER CONVEYOR

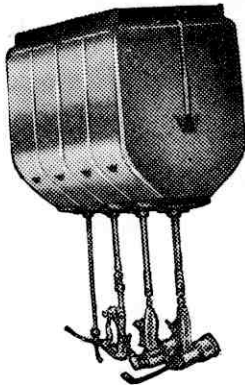

## World Famous **ALEMITE** LUBRICATION EQUIPMENT

- Floor and Overhead Hose Reel Units.
- Portable Drains and Lubrication Units.
- Control and Totalising Meter Valves.
- Red A Buckets and Utility Dispensers.
- Standard and Heavy Duty Pumps.

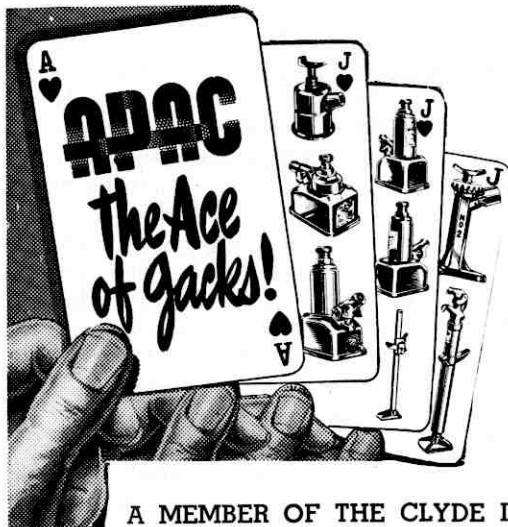

A MEMBER OF THE CLYDE INDUSTRIES GROUP.

# IMPRESSIONS

By O.

*Life in Australia is not so bad, after all.*

I hadn't been in Australia for three weeks, yet I felt like going home—never to return again. All the glamour and excitement of arriving at a new country had worn off—only the cold, gloomy, monotonous repetition of days was left. I asked myself why I ever decided to come here in the first place. It really wasn't that hot.

I would venture to say that these are the thoughts and feelings that many a student gets when he first arrives. And to aggravate things, he has to adapt himself to Aussie conventions, cope with home sickness, wander aimlessly up and down Rundle and Billy Street, without anything to do except attend lectures, eat sausages, pies, lamb's fry, oddly spiced cakes (all equally revolting!), and altogether it's a dog's life. Now, as I look back, I can't quite imagine how I ever got through that stage; but I did.

As the work piles on, and you try to figure out how you can best get away with the minimum swotting, life begins to put on a rosier tinge. You make friends, your activities are enlarged, your evenings are filled; life in Australia is not bad, after all.

Did I say not bad?

Golly! The finals are on top of you. That's how bad it is. Never had a quiz like this before. Messrs. Davey or Dyer wouldn't dream of anything like this. How's it gonna be—it's terribly strange with all these chattering girls about—now what was that formula again?—should I multiply by "g"?—chance it!—fortnight of torture—how did it go, boy?—you're through. The paper says so.

Well, time flies, and before you can wink your little eye you feel that you've settled in, and life's almost like home—because this is your home now. But problems do crop up time and again.

Although you've come to feel comfortable in your surroundings, you've not got a permanent "home" of your own—a place where you are free to do things of your own choice and interest, a place where you do not have to oblige, to abstain from, conform with, constrain in—a place where there is no prejudice—a place where there is love and happiness. Those who have been lucky have found good places to stay, where the occupants are understanding, don't over-charge, and provide good food. To those others who shift a few times each year, eternally seeking, seeking, life's a constant source of movement: and in its course these chaps learn more about the houses, streets, and suburbs than any permanent resident does in the same amount of time. (The person at present holding the record has moved twenty-five times during the last four years or so.)

One other thing that a new student just out has to get used to is the apparent worthlessness of the £A1. Although £A1 equals \$7 (Malayan), it buys as much goods as one dollar would. The prices at times appear to be exorbitant, and one cannot help but do a quick mental calculation to see if the transaction is worth while if conducted in Malayan dollars. Very often it is not, and this fact is quickly brought home when you've got to get things such as sports coats, overcoats, jumpers, thread, needles, buttons, moth balls, etc., etc., none of which ever even enters into the normal life of the poor boy in Malaya. A harassing and humiliating impression that I'm being taken for a sucker always comes to the back of my mind whenever I pay some cash over the counter. One does it without so much as a squibble or a hagggle, which is an excellent reminder that a fool and his money are soon parted.

Of course, you find characters all over the world, but very seldom so many that tell you that "it is a nice die to die." The weather may be an endless source of conversation, but to the person who comes from a place where the days are always "nice," it can sometimes be a bit tedious. But then, I suppose, it is better yabbering than "I've got the good oil on the 2.15." or "Let's have a stroll down to the Richmond."

One is forever beset with questions. "How long have you been here? What do you think of the cold? I suppose it is hard for you to get used to our Australian food." I've yet to meet the person who has not tried to be polite in reply to these; many have developed stock answers to them. It is torture to go to a new barber; you get it all over again. From the like and other things that are said, the average Australian appears quite ignorant about what happens outside his sphere of livelihood.

All being said, he remains a rough and sincere person inside. Perhaps he lacks politeness and polish, but he tries hard to create a friendly atmosphere. When the boss is not around, he's taught me how to bludge. War stories are a favourite, but what happened with that sheila could be interesting, too. He may also be a person who is not seen for three-quarters of the year, but makes his snoring appearance on the lawn in summer.

These impressions have been fleeting. They are not opinions, but rather stray thoughts that have been gathered here and there.

In spite of all difficulties and peculiarities that an overseas student has to face up to, he enjoys it. He does not want to act and appear an outsider, to be handled with special care, but rather like one of the cobbers.



# ERIC

By W. N. HOLMES.

*The inherent difficulties associated with the production of a student publication.*

It is some years since a magazine such as Hysteresis appeared, and one thing is certain—the thing will appear for, because of, in the interests of, and, in all likelihood, despite the students of the Adelaide Faculty of Engineering. The editor faces many difficulties, such as finance, printers, and copy.

Copy will eventually be almost entirely written by the editor. At the tenth hour the editor will realise that he must burn the midnight oil. Gathering various publications around him, this man of steel will gird himself, and so on.

At this point it is possible to gain some indication of the editor's character from the way he sets about his task of writing the magazine.

Consider the cowardly editor. Distinguishing traits are (in brief):

- (1) Sheets and sheets of copy in poor handwriting for the S.R.C. girl to type.
- (2) Unwholesome addiction to cribbing from local medical students' magazine and interstate and overseas engineering rags.
- (3) Insidious adoption of University Calendar type layout.
- (4) Prolific occurrence of "continued on page umpty-ump," as in "Saturday Evening Post."
- (5) Pondering photo and paragraph from Who's Who, 1956, of editor's Professor and Senior Lecturers.
- (6) Daringly critical criticism of present engineering course.

A far different type is the "slant" type editor. This person has one side to his character, which indicates a one-track mind. This bias may be art, chess, music, chess, single-bladed gas turbines, chess, sex, or religion. To give an idea of the type of trash this person will turn out, assume that he is, in this case, a numismatist.

His foibles are:

- (1) Ghastly Australian Stamp and Coin Quarterly type layout.
- (2) Avaricious inclination towards conducting correspondence with S.R.C. postage stamps.
- (3) Relatively uninteresting articles of the "Statistical Distribution of Ancient Roman Denarii along the Hadrian's Wall Area, with Particular Reference to the Economic Stability of the Roman Empire" type.
- (4) Rather more interesting articles, of the "A Pen Portrait of Rowland Hill" type.

- (5) Unintelligible and incomprehensible articles of the "Phase Diagrams of Silver, Copper, and Gold Alloys" type.
- (6) Daringly critical criticism of the present system of periodical fee raising from all aspects.

The editor of this here Hysteresis is, of course, of the courageous, unimpeachable, magnanimous, imaginative, and irrepressible group.

Thus one may expect:

- (1) Sunday Mail Comic Section type layout.
- (2) Welcome addiction to cribbing from "Outstanding Science Fiction Magazine."
- (3) Speed typing (with follow-up) by S.R.C. typiste.
- (4) Exceptionally interesting academic articles of the "I Was Professor Orr's Best Friend" type.
- (5) Deplorably interesting articles of the Woman's Weekly "For Teenagers—How to Improve Your Bust" type.
- (6) Tantalisingly interesting articles of the S.C.I.I.A.E.S., cribbed from Dr. Kinsey, "Manual of Immortal Immoral Tendencies Among Engineering Students" (with Appendix giving detailed Case Histories) type.
- (7) Pen Portrait studies and social scandal stories of unpopular members of staff. (Such gems of candid journalism are easily manufactured by cribbing from Truth, with the insertion of thinly disguised pseudo-pseudonyms.)

Given an editor of such calibre, how can a magazine go wrong?

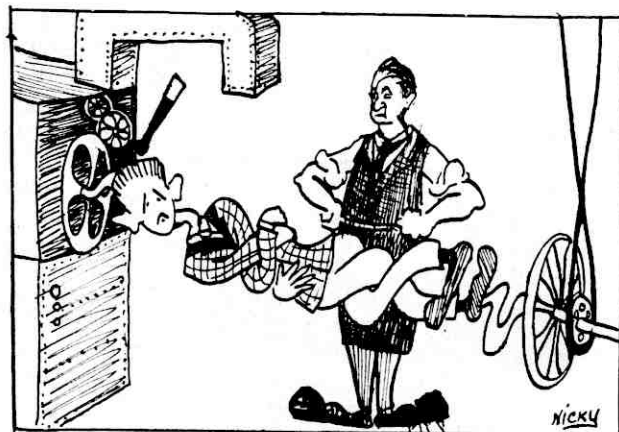

"You silly, twisted boy."

# WHITE OR RIGHT?

By IAN HAIG

*Australia must revise her immigration policy towards Asians.*

Australia must revise her immigration policy towards Asians.

This was the outstanding impression I gained from a month spent talking with Asians as an Australian delegate to the first Asian Student Press Conference in Manila, and on a goodwill tour of Formosa.

In the past few weeks Australian statesmen have spoken at length on Australia's desire to be friendly with her neighbors.

They have apparently chosen to forget that the people who are our near neighbors are eagerly awaiting some proof of our neighborly intentions in the form of a revision of our immigration policy towards them.

It is hardly consistent with our neighborly policy that while we expect to be allowed entry freely into Asian countries, we do not reciprocate with similar privileges.

The question of White Australia, as our policy towards Asian immigrants has come to be known, is still very much alive in Asia, as any Australian who has travelled in the area will testify.

Time and again I was asked why people who claimed to want friendship practised racial discrimination against their potential friends. For, whether we like admitting it or not, White Australia is racial discriminaton.

My answer always had to be that changes were taking place, and there were signs of a change in White Australia.

I talked of the Colombo Plan and its benefits, and my Asian friends would be most appreciative, "but," they would say, "we still feel that you look down on us."

---

## ABOUT THE AUTHOR.

This guest article is written by an Arts student. Mr. Haig, an ex-editor of "On Dit," represented Australia at a Student Press Conference held in Manilla during this year.

As well as spending two weeks at Manilla, he also travelled to Formosa. At both these places he was able to talk to many people from all over Asia on many different subjects.

Because of the importance of Australia's relationship with Asia, it was felt that an article should be included on this subject.

We, as students, have the most contact with Asians, and it is our obligation to tell what we have found regarding complete equality of all men, and assimilation of people from other races and cultures.

They would hasten to point out that they did not expect Australia to open its doors to large scale Asian immigration, but they merely want to see some system established, a quota system being the most practical, whereby the racial snub is removed.

This feeling was particularly evident among Filipinos, who are still smarting from the insult of the refusal to admit Sgt. Gamboa in 1949. (Sgt. Gamboa, a Filipino war veteran and member of the U.S. Army, married to an Australian girl, was refused admission to Australia in 1949. The case brought world-wide criticism of Australian immigration policy.)

Often during my stay in the Philippines I was asked about the Australian attitude to Gamboa, and White Australia generally. I explained that the 5,000 Asian students in Australia were an influence in our Universities and on public opinion, but pointed out that White Australia was a long-established doctrine which would take time to change.

"But all we want is something like a quota system, which would be proof that you do not discriminate racially," they would insist.

Delegates from all over Asia, Government officials and casual acquaintances, were all of the same opinion—a quota system would be sufficient. After all, the U.S. found one practicable.

The old Australian agreement that our labor market would be flooded with cheap labor, and our standard of living lowered, was invalidated by a quota system, as the Government could still regulate the number of immigrants.

The establishment of a quota system, then, performs the chief function of reassuring Asians that we do not wish to discriminate against them on racial grounds, and also allows regulation of the flow of immigrants.

Conference delegate Sparling Da Costa, of Ceylon, summed up the opinion of those I met when he said: "We feel that White Australia is a doctrine of racial superiority, and we often tend, as a result, to treat Australians with suspicion."

Others I met were even more direct.

A Filipino radio technician said as he met me: "Australia? All I can remember of Australia is Gamboa!"

His friendly and hospitable countrymen no doubt berated him afterwards for this outburst, but he left no doubt as to his feeling on our attitude to Asian immigration.



Others spoke with varying feeling; but even the most pro-Australian were definite that White Australia lowers Australian prestige in Asia.

Some of our hosts admitted privately that they were apprehensive lest the Australians should not want to dine with Asians. These cases were extreme, but they underline just how deep-rooted the feeling is that Australians practise racial discrimination.

I found this uneasiness in people in all walks of life—taxidivers and students, businessmen and officials—they merely feared that we would not want to be friendly with them.

The more informed were more aware of the arguments for and against White Australia than the average Australian, and discussed them at length; but they all concluded that a quota system is the solution to our problems.

Australians argue that a quota system is only the thin edge of the wedge which will eventually allow unrestricted migration. Yet only six out of the 23 U.S. quota areas in the Far East regularly fill their quotas!

The fear of the high Asiatic birthrate, another old argument, is also invalidated when we note

---

The little old grey lady bent over the cherub in the cradle.

"O-o-oh. You look sweet. I could eat you."

Baby: "Like hell you could; you haven't any teeth."

the small numbers involved in a quota system—the U.S. quota for a given area rarely substantially exceeds 100 annually.

The ease with which Asian students have fitted into the Australian picture is an indication that the assimilation of small numbers of Asian immigrants would not be very much harder.

It was pointed out to me that Australians are only too willing to accept Asian countries as allies, and to trade with them; however, their willingness to benefit from Asia did not extend to a willingness to accept Asians as permanent immigrants.

The people of Asia have made great strides towards national maturity in the past decade, and this maturity is making them increasingly aware of racial slights.

Australians are not hesitant in condemning racial discrimination in South Africa and the U.S. It is time we took stock of our own racial prejudices.

---

A wolf lounging in a hotel lobby perked up when an attractive young lady passed by. When his standard come-on, "How-de-do?" brought nothing more than a frigid stare, he sarcasmed:

"Pardon me. I thought you were my mother."

"I couldn't be," she said. "I'm married."



**WE depend on YOU**  
**to look to**  
**"the metal of the future"**  
**... ALUMINIUM ALLOY**

Your foresight NOW, in recognising the enormous potential of aluminium alloy castings in Australia's industrial development, will help YOU, and ourselves, to shape the products of the future. So that you may gain first hand knowledge of this light-weight, high tensile, non-corrosive metal, we cordially invite you to call or write for details of our production potential, advisory, and designing services.

**CASTALLOY** LTD,  
TRADE MARK

S.A.'s PIONEER ALUMINIUM ALLOY FOUNDRIES  
314 WAYMOUTH ST., ADELAIDE. LA 3438

# CIVIL ENGINEERING ACTIVITIES

*This is just to let you know that the staff do a little useful work every now and again.*

In addition to the fundamental research programme which forms an important part of the work of any University Department, the Civil Engineering Department finds itself not infrequently involved in research or investigational work of an "ad hoc" nature connected with some engineering project in South Australia.

These investigations provide an important link between the University and the engineering community from which, we believe, both sides benefit. Many of the problems tackled have become absorbingly interesting, and from some, valuable discoveries have been made.

Typical of the sort of work is the current investigation on a problem to do with the power stations at Port Augusta. Both the present "A" station and the future "B" station will eject vast quantities of condenser cooling water into Spencer Gulf. This water will be considerably warmer than the water in the Gulf. It is most desirable that it is diffused out into the Gulf, and does not find its way back into the cooling water intakes. The separation of inlet and outlet water must operate for all conditions of tide.

The basic investigation was to study the general flow patterns, and to establish the most economical form of separating the inlet and outlet streams. In order to do this, a model to one fiftieth scale was constructed of the area adjacent to the power stations. The model represents about one mile by half a mile of the actual Gulf. The bed of the model was correctly formed in concrete to represent the true bed of the Gulf. Several pumps, automatically controlled, cause the water to rise and fall, and to flow up and down the "Gulf" to represent typical tidal cycles. Miniature power stations on the model eject metered quantities of hot water, and this is tracked as it passes into the "Gulf." Continuous records of temperature are made at various points, to check the amount of interference for any particular arrangement of baffles.

As an interesting complement to the model tests, some full-scale work was undertaken at the actual site of the power stations. In these checks the condenser cooling water outlet was charged with dye. The diffusion of the dye into the Gulf was followed by skin divers armed with thermometer and depth gauge instead of spear gun. These full-scale checks gave excellent confirmation of some of the features discovered on the model.

This particular series of tests was made in close co-operation with officers of the E.T.S.A.

Another recent project done in co-operation with E.T.S.A. was the development of a new form

of transmission tower. These towers are designed for the 275 Kv lines which connect Port Augusta with Adelaide. The problem, simply stated, was to devise the most economical form of structure which would sustain the specified loading. Economy in this case must consider such items as costs of transport and erection in areas remote from Adelaide.

The structure evolved by the University is a three-dimensional frame made out of steel tubes. The frame is pre-stressed by wire ropes so that the principal load carrying members are held in compression.

Calculations were made to establish the optimum geometry for such a frame. When this had been determined, a number of models one-seventh full scale were constructed and tested to destruction in the laboratory. From the results of these model tests the design of full-scale towers was undertaken with some feeling of confidence. Some full-scale towers 70 feet high were constructed and tested to destruction. Such tests must simulate not only the effect of wind loads, but must include the dangerous condition of unbalance pulls which would follow the failure of one conductor. The University has no facilities for carrying out such large tests, and these were made at the E.T.S.A. yard. In all the tests the new form of structure behaved very much as predicted. It is possible that a few towers of the new design will shortly be put into service. (The Trust has just announced that they intend using at least 900 very soon.—Ed.)

Another large-scale project with which we were connected concerned navigation at Port Pirie. The approach to the loading berths is quite narrow, and it was observed that, as ships passed up the channel, they caused serious disturbance to other ships tied up at the quays. This disturbance tended to cause damage to mooring fittings on both the quay and the moored ships.

Full-scale observations were made at Port Pirie to study the nature of the phenomenon, after which model tests were conducted in the laboratory. These involved towing model ships up a flume representing the Pirie channel. The disturbances created for various conditions of speed and channel section were measured. Further measurements were made in an electrolytic tank, in which an analogy is drawn between the flow of water past the ship and the flow of electricity in a bath of electrolyte, the latter being modelled to represent the ship and channel.

From the results of this investigation it was found possible to recommend ways of minimising the disturbances to moored ships.

# **Good engineering..**

*.. is fundamental to a high material standard of living*

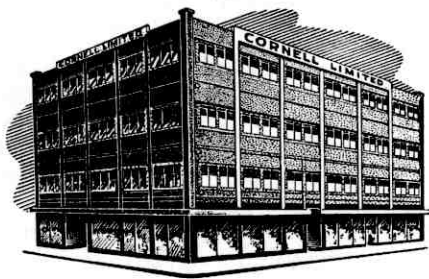

**SEE  
OUR  
WINDOWS**

May we suggest that you inspect the display windows on our Pirie and Hyde Streets frontages occasionally. A selection of tools and engineering equipment is on display. By no means comprehensive because of window limits, it may serve, however, as an introduction to our range.

*and **GOOD ENGINEERING** depends in large part on an adequate and efficient supply of quality hand and machine tools!*

*It has been argued with reason that good engineering is the basis of our material civilisation. Certainly it is true that engineering itself depends on the supply of the proper tools of trade. Cornell Limited has specialised in the supply of specialised tools of trade and industrial equipment. As wholesale distribution has been its business since 1879, it is natural that when engineers, purchasing officers, and production managers think of tools and equipment, they think of . . .*

**CORNELL LIMITED**  
**122 PIRIE STREET, ADELAIDE. W2311**

WHOLESALE DISTRIBUTORS SINCE 1879

An unusual investigation completed last year concerned ventilation troubles in one type of bus used by the M.T.T. On first sight such an investigation would appear out of place in the Department of Civil Engineering. The work of a civil engineer is, however, frequently concerned with air flow, particularly the action of wind on bridges and buildings. In this particular case the ventilator intakes in the front of the bus did not appear to function. Instead, the air tended to come in through the rear door, bringing with it all the road dust. One method of investigating this phenomenon would have been to use the wind tunnel, but in this case we decided to carry out full-scale tests. To do this we lashed an Army type smoke generator to a special boom sticking out from in front of the bus. The bus was then driven along at service speed through the smoke. Meanwhile, a further car containing observers and cine cameras was driven parallel to the bus some 20 feet away. Needless to say, such an outfit is not recommended for use on a public road! To do these tests we borrowed the main runway at Adelaide Airport during some clear periods between flights. The tests showed quite clearly why the ventilator intakes were not working, and indicated where improvements could be made.

If bus ventilators appear a little outside the normal province of Civil Engineering, it is perhaps even more difficult to imagine that we should be asked to carry out an investigation in the Cathedral, yet such is the case. This investigation, a

few years ago now, arose from the distressing habit of the bells in the Adelaide Cathedral losing their clappers. The clapper on the biggest bell weighs about 50 pounds. As might be imagined, the consequences of this mass coming adrift up in the tower are unpleasant, to say nothing of putting the bell out of action.

In order to find out what was causing these failures, strain measurements were taken on one of the clappers while the bell was being rung. To find out where the clapper was during the swing of the bell, volunteers from the staff lay flat on their backs under the bell, with only inches to spare as the bell swung over them. The measurements taken revealed some very high stresses in the clapper. A re-design by the University was submitted, and this, so far, has proved entirely satisfactory.

In making these tests it was necessary to ring the bell at irregular intervals. This was the cause of a moment of light relief. After we had been working in the tower for some time, footsteps were heard on the ladder coming up to the bell loft. The feet responsible proved to be those of a policeman, who rather aggressively demanded to know what was going on. An impressive display of electronic gadgetry probably persuaded him from taking more precipitous action. It transpired that someone had rung the police informing them that a group of madmen were loose in the Cathedral trying to ring the bells. We have been wondering about that ever since!

## THE SENTIMENTAL N.S.T.

(With sincere apologies to the memory of C. J.  
Dennis, and extracted from Cranks and  
Nuts, 1954)

Ever heard of Nashos?  
Unlucky \_\_\_\_\_ coots,  
All is \_\_\_\_\_ orders  
Like "CLEAN YER \_\_\_\_\_ BOOTS!"  
Yer a guest o' \_\_\_\_\_ Menzies,  
They treat yer \_\_\_\_\_ well.  
Food and bed laid on,  
Like \_\_\_\_\_!

Chorus:

Chargin' \_\_\_\_\_ dummies,  
Firin' \_\_\_\_\_ guns.  
Throwin' \_\_\_\_\_ hand grenades  
Gives yer the \_\_\_\_\_ runs.

Revally in the mornin'  
Out o' \_\_\_\_\_ bed.  
'Arf an 'our's drillin'. Hell,  
Yer \_\_\_\_\_ nearly dead.  
The chow is filthy muck,  
Stews an' \_\_\_\_\_ hash,  
Then yer made to sleep  
In a pally \_\_\_\_\_ ass!

Chorus:

A week o' kitchen duty,  
Dishin' \_\_\_\_\_ slops,  
Peelin' \_\_\_\_\_ spuds,  
And pushin' \_\_\_\_\_ mops.  
Next yer on a root march,  
Luggin' \_\_\_\_\_ packs.  
Fightin' \_\_\_\_\_ nothin',  
That's bivo \_\_\_\_\_ wacks.

Chorus:

When yer thinkin' o' some sleep,  
Hell, bed's \_\_\_\_\_ hard.  
Sleep? sez \_\_\_\_\_ Sarge.  
Yer on \_\_\_\_\_ guard.  
Wot's the use o' moanin',  
Obey the \_\_\_\_\_ Sar.  
They say it's fer the good  
Of Australi \_\_\_\_\_ ar!

Chorus.

ANONY \_\_\_\_\_ MOUS.





### A.E.U.S. COMMITTEE

Back Row: B. L. Kelly, P. Clayton, R. L. Bamford, F. J. W. Symons, C. Hastwell, M. G. Symons, D. J. Fisher, T. L. Pascoe, J. F. Bateup, P. G. Boros.

Front Row: B. D. Shakes, R. J. Kelly, K. R. Weller, R. W. Hercus, D. J. Watson.

#### JOHN KELLY

"Men, some to business, some to pleasure  
take, but . . . ."

President. Final year. Has been top of every subject he has taken since 1950. Doing Honours Chem. Has an occasional lost week-end, but despite all this, is still a good bloke.

#### PETER BOROS

"With men he can be natural and unaffected, but when he has ladies to please, every feature works."

Vice-President. Fourth year. This man is quite remarkable and unpredictable. He tries to run the show, and is a member of the Liberal, Labour, and Socialist Clubs. Doing Civil.

#### FRED SYMONS

"Of manners gentle, of affections mild,  
In wit a man, simplicity a child."

Secretary. Fourth year. Electrical when he has time to go to the lectures. The boy who really runs the show: irrepressible. Does not give much away, but will get married sooner or later.

#### BOB HERCUS

"I could well be moved if I were as you,  
But I am constant as the northern star."

Assistant Secretary. Fourth year. Queer species. Can't make up his mind whether to do Mech. or Elec.; at present doing both. Works like a horse, but is handicapped by big blinkers. Is NOT a member of the Liberal, Labour, or Socialist Clubs.

**MARK SYMONS**

"A young man married is a man that's marred."

Treasurer—and tight as they come. Destined to be a Civil Engineer. Spends all his spare time trying to get a parking permit for his car. It's rumoured he's going overseas next year.

**KEITH (SAM) WELLER**

"I am bewitched with the rogue's company."

Fourth year. Is known affectionately as N.E.F.B.D. Can't ride a horse or play poker, but still one of the boys. Another industrial chemist, but somehow manages to keep sane.

**DAVID FISHER**

"Oh, what may man within him hide,  
Though angel on the outward side."

Publicity man. Keeps in the background, but a persistent worker. Can't tell you any more, except he's doing Chemical.

**BRIAN SHAKES**

"Take him as he is."

Fourth year. Doing Chem. Eng. A gentleman and a scholar, despite all allegations to the contrary.

**JOHN BATEUP**

"Give me, next good, an understanding wife."

Fourth year Electrical. You have to watch this character; he can, and does, do almost anything at any time. President of the S.C.I.I.A.E.S., getting married not soon enough.

**DAVID WATSON**

"There's something on his mind,  
And I do doubt the hatch and the disclosure  
Will bring some danger."

Third year. Although he does not seem to put much effort into it, has one of the largest harems in Adelaide. Bit of a smoothy. Doing electrical. Plays football in his spare time.

**PETER CLAYTON**

"Lest men suspect your tale untrue,  
Keep probability in view."

Occasionally turns up to committee meetings. Another Chem. Engineer. Is attracted irresistibly to cameras and photographers.

**BRYAN KELLY**

"This have I had thee, as a dream doth flatter,  
In sleep a king, but waking, no such matter."

Second year. Also doing Chemical. Goes to sleep at committee meetings. Parts his hair on the left-hand side, and got a distinction in Chem. I.

**TIM PASCOE**

"A wonderful glory of colour,  
A splendour of shifting light—  
Orange and scalet and purple—  
Flamed in the sky tonight."

First year. In spite of the fact that he wears a green tie, yellow pullover, and brown corduroy trousers, is quite a good chap.

**COLIN HASTWELL**

"I'll talk a word with this same learned Theban:  
'What is your study?'"

First year. Tall, fair, and handsome. Has a good right arm. Seems a good bloke. He stars at First Aid.

**IAN KELLIE**

"'Tis a question left us yet to prove,  
Whether love lead fortune, or else fortune love."

First year. This electrical engineer wears a hat. Suffers from a "one-woman" disease.

**BARRY WARREN**

"I count myself in nothing else so happy  
As in a soul remem'bring my good friends."

First year. Architect, and in the Tug-o'-war. Seems to have plenty of energy. We'll use all that up.

**ADELAIDE UNIVERSITY ENGINEERING SOCIETY****STATEMENT OF ACCOUNTS TO 9/8/56**

CREDIT				DEBIT			
	£	s.	d.		£	s.	d.
Balance, 22/9/55 -	--	--	--	85	17	8	
Subscriptions and Sale of Badges	--	--	--	62	0	0	
Receipts, Ball	--	--	--	164	8	0	
Receipts, Dinner	--	--	--	30	10	0	
Receipts, Informal Functions	--	--	--	3	0	0	
Donations	--	--	--	9	13	6	
S.R.C. Grant	--	--	--	35	0	0	
Bank Interest	--	--	--	2	13	3	
				<u>£393</u>	<u>2</u>	<u>5</u>	
Cost of Badges	--	--	--	27	10	0	
Freshers' Welcome	--	--	--	4	11	8	
Informal Functions	--	--	--	10	12	10	
Annual Ball	--	--	--	112	18	6	
Dinner	--	--	--	84	9	3	
Indian Exchange Scheme	--	--	--	4	5	0	
Rope	--	--	--	8	15	8	
Presentation	--	--	--	2	7	6	
Petty Cash	--	--	--	5	0	0	
Balance at Bank, 9/8/56	--	--	--	132	12	0	
				<u>£393</u>	<u>2</u>	<u>5</u>	

Certified correct 11/9/56 by MR. JAMES H. FOWLER.



# MATHEMATIKA

## HOW MANY BEANS MAKE FIVE?

*They spoke not a word ;  
But like dumb statues, or breathing stones,  
Star'd at each other, and look'd deadly pale.*

Of all the examples that can be used to demonstrate the value of the application of mathematics in the investigation of commonly discussed problems in the sister sciences, the present example is probably supreme. Here, in the complexity of a problem of enumeration in the science of horticulture, is contained a pertinent query to which rigorous mathematical analysis alone can produce a fitting and conclusive answer. The horticulturist, within the sad limits of his science, can, of course, discourse learnedly regarding his pulses, Mendelian theories, and carbohydrates, but when faced with the problem of calculating the exact number of beans which, added each to each, will result in a total of five, he can only appeal to the mathematician for advice and guidance. The true mathematician will never withhold such assistance, and accordingly we proceed to formulate a discussion and proof to resolve the horticulturist's difficulties. That is to say, we shall indulge in a mathematical beano or beanfeast.

The operative material in this unusual problem is the vegetable, *Phaseolus vulgaris*, i.e., beans.

Mathematics is well supplied with beans, such as, for example:

- (1) The cusp,  
or French bean . . . . .
- (2) The cycloid,  
or broad bean . . . . .
- (3) The omicron,  
or old bean . . . . .
- (4) The empty bean pod,  
or has been . . . . .
- (5) The ellipse,  
or coffee bean . . . . .
- (6) The Heinz,  
or baked bean . . . . .

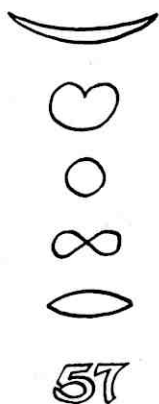

and so on.

Now, beans can be cooked, or be spilled, or be given, but consideration of the problem as set forth indicates that in this particular case they are to be summated, or counted. We need not, therefore, concern ourselves with the more abstruse or complicated type of mathematical bean, but can confine our researches to the variety with the arithmetical flavor—that is, item (6) above, represented mathematically by the symbol 57.

Let the number of beans which make five be  $n$ .

To indicate that they ARE beans, and not any other form of unknown vegetable quantity, we associate the term  $n$  with our symbol of beanery, 57, thus:

$$\text{Number of beans which make five} = 57 + n \dots (1).$$

Clearly, 57 is a number which is odd, unusual, and has about it a certain indefinable atmosphere of mysticism. We can therefore, with advantage, analyse this number further, and, with our usual precise and cogent reasoning, we can state that 57 is:

- (a) compounded of the two digits 5 and 7, which
- (b) added together produce exactly 12, and
- (c) When subtracted leave a remainder of no beans.

That is to say, from (a), (b), and (c) the significance of the bean factor 57 can be resolved as:

$$5 + 7 + 12 + 0 \dots (2)$$

whence from (1) it is evident that the solution to our problem is contained in the summation of five terms (in keeping with the given expression), i.e.,

$$\text{Number of beans which make five} = 5 + 7 + 12 + 0 + n \dots (3)$$

Consider (3). Clearly there is still present a degree of mysticism which must be eliminated. When in difficulties of this sort, it should be remembered that, by the substitution of symbols for the unwanted quantities, such difficulties can be overcome. The simplest form of substitution which can be effected in this case is, of course, that of employing letters of the alphabet corresponding to the integers in (3), i.e.,

$$\text{Number of beans which make five} = 5 + 7 + 12 + 0 + n = e + g + l + o + n \dots (4)$$

Now,  $g$  is the acceleration due to the gravitational attraction of the earth. In horticulture, however, there is no earth, but only mould ( $m$ ), and substituting this for the term  $g$  in (4) we have:

$$\text{Number of beans which make five} = e + m + l + o + n,$$

Which, by a simple transposition, is equal to a LEMON.

That is to say, when presented with the problem, "How many beans (*Phaseolus vulgaris*) make five?" the horticulturist should state that "The answer is a lemon (*citrus medica limonum*)"—a fitting and conclusive solution to the given problem.

AUTOMOTIVE AND INDUSTRIAL BEARING EXPERTS AT YOUR SERVICE! . . .

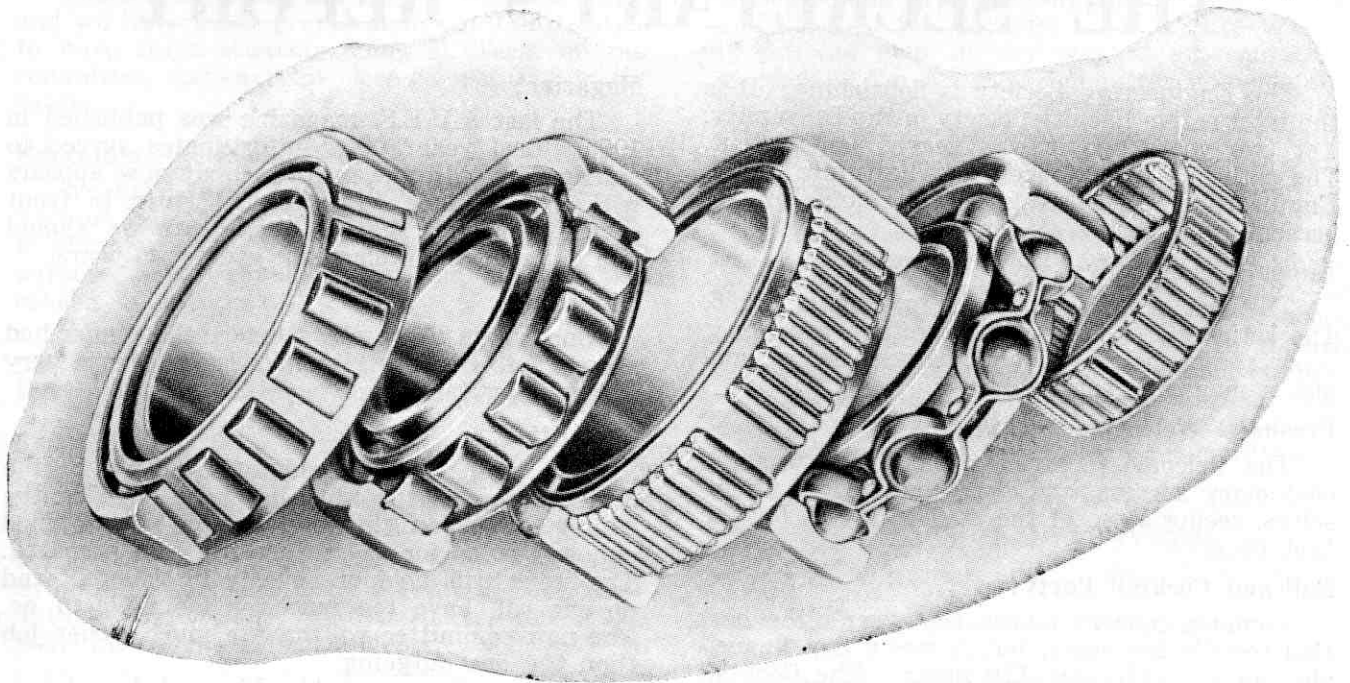

# Duncan's— Adelaide's leading Bearing house!

From the tiny rollers in an electrical hand drill to the giant bearings in an ore crusher or for the axle box of a modern diesel electric, Duncan's can supply the right bearings for the right job.



## Mr. Jack Peake (Duncan's Bearing Expert)

Jack is recognised as having the best knowledge of automotive and industrial ball and roller bearings in South Australia. He has been with Duncan's for over 30 years and is well qualified to give technical advice.



*RING W 3341 . . . Duncan's complete range of automotive and industrial bearings include "Timken", "Hoffman", "F.B.C.", "Fajnr", "M.R.C.", "R.B.C.", and Nice Ball and Roller Bearings . . . "Weston and Gits" Oil Seals; Seeger Circlips.*

**DUNCAN** & CO.  
LTD.

**107 PIRIE STREET, W3341**

*"The Friendly, Wholesale Suppliers"*

# THE SECRETARY'S REPORT

The Engineering Society is flourishing. It is the most active Faculty Society in the University. Yet two years ago it was nearly non-existent. The path has been pioneered. The future of the Engineering Society rests in the hands of the present Engineering students.

## Annual General Meeting

The last A.G.M. was held in August, 1956. The retiring President and Secretary gave their reports, and the new committee was elected, and also a magazine committee.

## Freshers' Welcome:

The welcome to freshers this year was the customary success, and everyone enjoyed themselves, seeing some of the staff in action for the first time.

## Ball and Cocktail Party:

Common consent makes this year's the best Ball socially for years, but it was a flop financially, as we made only £10 profit. The Cocktail Party was also a huge success, and the various Ball Convenors are to be congratulated on their work.

## Staff-Student Tutorial Scheme:

This scheme, whereby every member of staff has half a dozen first year students as his group, which meets for lunch, etc., about once a month, is proving very successful.

## Talks:

Several very interesting and valuable addresses, some with slides, have been given this year, from "The Workers' View on Automation" to "What Professor Saw!" These have been reasonably well attended.

## Films:

Good use has been made of the various firms who are prepared to lend us films, and attendance at these has been very gratifying.

## Interfaculty Sport:

We have not been very successful this year, but next year we will scoop the pool. The Meds. won the tug-o'-war and rugby, but we beat the physiotherapists at hockey.

We challenged the Meds. at Aussie rules, but they presented us with an endless array of excuses why they could not play.

## Procession:

Once again the Engineers were very prominent in the Procession celebrations.

## Debate:

For the first time for very many years, a debate was held against the Meds. on "Respectability is a bar to progress." Although they supported the motion, the Meds. contradicted themselves by winning—by one point.

## Magazine:

The last A.U.E.S. magazine was published in 1950. Last year a few unfortunates agreed to manage and edit the magazine. It now appears with a new name, "Hysteresis" (turn to front cover). I think that in the future we should aim at producing a magazine every two years.

## Dinner:

Once again those who attended the dinner had a very full evening. Dr. Woods gave us a very entertaining talk.

## Committee:

This year, due to lack of tradition in the Society, most of the work has been done by the willing few. Now things have been straightened out, and plans for the future are well prepared. The work will be more evenly distributed, and no one will have too much or too little to do. The new committee will have a much easier job than the one outgoing.

Young and energetic blood is needed next year on the committee; you will thoroughly enjoy the experience while serving your friends.

## Engineering Faculty Bureau:

This year we have the National E.F.B. Director in Adelaide, and E.F.B. is a growing concern. It is running the Indian Exchange Scheme, prints "Torque" three times a year, and hopes to help in the field of interstate vacation exchange work.

## Students' Representative Council:

There were eight Engineers on the S.R.C. for half of this year, and seven for the remainder. This is a most desirable state of affairs, as the Engineer brings to the S.R.C., normally a rather woolly organisation, an attitude of realism. I would heartily recommend any Engineer who has the inclination, energy, and interest to stand for the S.R.C. and/or the A.U.E.S. committee.

## Informal Functions:

Last year we held a very successful informal dance with the Physiotherapists, and we are having one again this year. The function promises to be very popular in the future.

## S.C.I.I.A.E.S.

At last we have formed a branch of the S.C.I.I.A.E.S. in Adelaide. This is an autonomous society, and is not connected constitutionally with the A.U.E.S., although some people are prominent in both. The society exists for good clean fun, despite all appearances.

## Faculty of Technology:

We now have a sister Faculty of Technology at the University of Adelaide, in its first year. We are very desirous of incorporating the students of both the Engineering and Technology Faculties in the A.U.E.S.



There is no doubt that this is the best thing, and we have made provision in our Constitution to have three students doing B. Tech. on our committee, and envisage close co-operation in the future.

#### Education Sub-Committee:

We have formed this committee, but as yet its work has only been in the embryological stage, thinking exactly what should be its aims and purpose, how it should be run, and who it should consist of, etc.

Nevertheless, when under way this committee may be able to make a worthwhile contribution to the Engineers and their courses.

#### Symposium:

Next year, in the May vacation, Adelaide is holding a Symposium on "Nuclear Engineering" for E.F.B. Sydney held a very successful Symposium on "Automation" this year. Next year's Symposium promises to be a great success, intellectually and socially. But its success depends on you, the Engineering students. You may be

Professor: "Didn't you have a brother in this course last year?"

Electrical Student: "No, Sir. It was I. I'm taking it over again."

Professor: "Extraordinary resemblance, though—extraordinary!"

asked to help in many ways, such as providing a billet for a few days for an interstate visitor. If you can help in any way at all, contact a member of the A.U.E.S. committee immediately. We need many willing helpers. The more that help, the less each will have to do, and the greater will be the success of the Symposium. We are depending on you.

The Engineering Society is now on its feet, and standing upright on its own. It could topple and die. It could go on even more strongly—it now at least has a firm foundation. It does not really need much effort at this stage to flourish indefinitely, but if it topples, a great deal of effort will be necessary to put it back on its feet. The Society can do immeasurable good for those who join its activities and serve on its committee.

I wish it every success.

FRED J. W. SYMONS,

Hon. Secretary.

The Magazine Committee extend their thanks for the generosity of the Advertisers, without whose help this magazine could not have been published.

## See ALL-BRITISH . . . Today . . . for

# AUSTIN

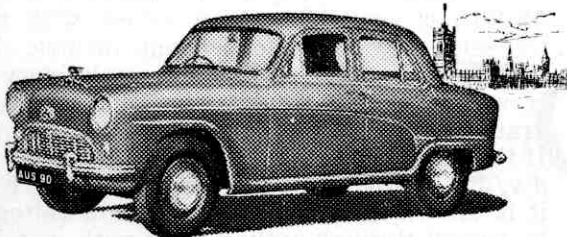

**AUSTIN A95**

The quality car of the year . . . A95 has beauty in its new and elegant lines . . . A95 has luxury in its splendid appointments, and power to spare in the big 85 horsepower, 6-cylinder engine. For the man who wants a big, fast, spacious, luxuriously finished car at a very moderate price, then AUSTIN A95 is the perfect choice.



**A55 "Cambridge," Mark II**

. . . the fine car at the family price . . . A55 gives you more good motoring features than any car near its price—plus luxurious comfort and deluxe interior refinements. A55 "Cambridge" beats all rivals for sheer value for money . . . AUSTIN—you can depend on it!

## THE ALL-BRITISH MOTOR HOUSE LIMITED

77 PIRIE STREET, ADELAIDE . . . Phone: W 2131.

Branches at KADINA and PORT LINCOLN.

# THE UNIVERSITY OF ADELAIDE ANALOGUE COMPUTER

By L. W. A. GLASSON.

*Why, 'tis a fitting and a fair reply.*

The construction of this analogue computer is under the general direction of Professor E. O. Willoughby, with the detailed design and construction work being done by research students and technicians within the Department. When completed, this machine will be available for use by the various Departments of the University and outside organisations.

The primary use of an analogue computer is the solution of high order linear and non-linear differential equations. Such equations are both difficult and tedious to solve by analytical techniques. They arise in almost every branch of Engineering and Science in the course of investigation or design work. The application of such computers to design work is particularly attractive because of the ease with which various sets of possible conditions can be tried once a general problem has been set on the machine.

The name analogue computer suggests the basic principle of operation of the machine. An analogy is set up between quantities in the machine and corresponding quantities in the mathematical equation under consideration. In the Adelaide machine, as in the majority of analogue computers, voltages are used to represent the dependent variable and its derivatives, while time is the independent variable. The use of a voltage analogue arises from the ease with which voltage, as a physical quantity, can be transmitted, controlled, and measured.

An analogue computer consists of a collection of units each of which performs one of the following operations:

- (a) Addition.
- (b) Scaling (multiplication by a fixed number).
- (c) Integration.
- (d) Multiplication.

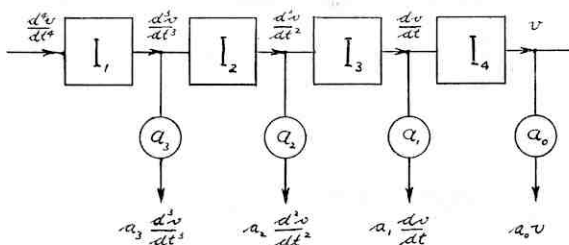

Figure 1

As an example: If a voltage  $v_1(t)$ , which is a function of time, is fed to the input of an integrating unit, then this unit produces an output voltage  $v_0(t)$  of the following form:

$$v_0(t) = \int v_1(t) dt$$

Similarly, the remaining units modify their inputs to produce the remaining operations.

Consider now how a collection of such units can be arranged to solve a differential equation. For simplicity, consider an ordinary linear differential equation of the fourth order with constant coefficients:

$$d^4x/dt^4 + a_3d^3x/dt^3 + a_2d^2x/dt^2 + a_1dx/dt + a_0x = f(t) \quad \text{-- -- (1)}$$

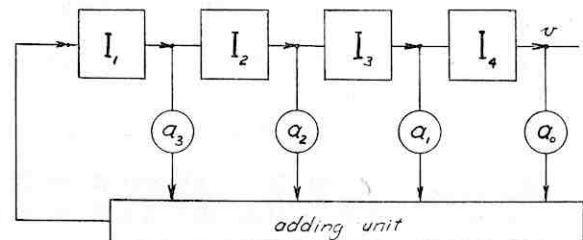

Figure 2

Solve for the complementary function only, that is, assume that  $f(t) = 0$ . Rewrite the equation in the following way:

$$d^4x/dt^4 = - (a_3d^3x/dt^3 + a_2d^2x/dt^2 + a_1dx/dt + a_0x) \quad \text{-- -- -- (2)}$$

Consider now Figure I. Suppose a voltage,  $d^4v/dt^4$ , is available, which varies with time in the same way as the dependent variable  $d^4x/dt^4$ , with only a simple scaling term relating  $v$  and  $x$ . Now this voltage  $d^4v/dt^4$  can be fed to an integrating unit ( $I_1$ ) to produce  $d^3v/dt^3$  at its output. If this is repeated using  $I_2$ ,  $I_3$  and  $I_4$ , then voltages  $d^2v/dt^2$ ,  $dv/dt$  and  $v$  are produced. In Figure I it is shown, in addition, that these voltages can be passed through scaling units with suitable settings to produce  $a_3d^3v/dt^3$ , etc. All the terms on the right-hand side of equation (2) are available. If now they are all fed to an adding unit, the output of this unit is the right-hand side of equation (2). This, by equation (2), is equal to  $d^4v/dt^4$ . But this is what was required at the input to  $I_1$ . If then the output of the adding unit is fed to the input of the first integrating unit, the machine will solve equation (1). Figure II shows the complete machine connection.

The voltage  $v$  can be recorded as a function of time, and subsequently reduced to the required function  $x(t)$  by suitable scaling. This method can be extended by the use of multiplying units and function generators to the general solution of non-linear equations.

The Adelaide machine, now in an advanced state, when completed will have the following units:

- 16 integrating units.
- 28 scaling units.
- 4 adding units.
- 3 function generators.
- 10 multiplying units.

In the case of the solution of the fourth order equation above, the following units were required:

- 4 integrating units.
- 4 scaling units.
- 1 adding unit.

Comparison of these two lists gives some idea of the complexity of the problems which the Adelaide machine will be capable of handling.

A certain engineering student sent a sample of his home-made beer to the Chem. Department to be analysed. A few days later he received a report:

“Dear Sir,—Your horse has diabetes.”

### “ VARIATIONS ”

O, Engineers have hairy ears,  
 Designing dams and ditches,  
 Controlling floods and blowing suds,  
 And never reaching riches.  
 When you want fun your tastes don't run  
 To graphs and mathematics,  
 But to the “pub” and “Clover Club,”  
 And ballroom acrobatics.  
 You make surveys or waterways,  
 And plan for irrigation,  
 But H<sub>2</sub>O to gin that's sloe  
 You aid in moderation.  
 With stress and strain you ascertain  
 The ways to make frames rigid,  
 Then spend the night till broad daylight  
 In making dames less frigid.  
 O, Engineers have hairy ears,  
 I find them most endearing,  
 By awfully odd because, by God,  
 They don't like Engineering!

$$\left\{ \begin{array}{l} \frac{1}{\text{cabin}} \text{ dc} = \log \text{ cabin} + c \\ = \text{houseboat.} \end{array} \right.$$

“QUALITY UNEQUALLED”

LION

AERATED WATERS AND CORDIALS



# THE MAGIC WORD IS TRICHLORETHYLENE



**disappears**

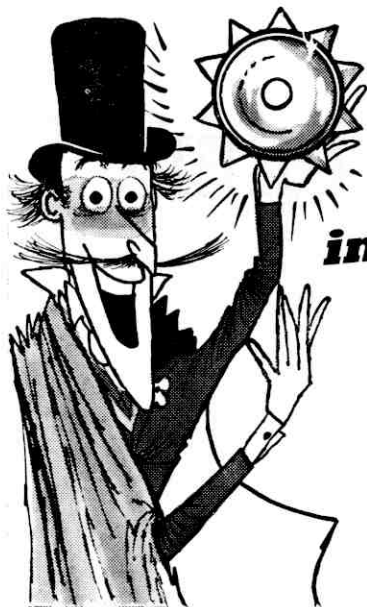

**in a flash...**

Your Metal Degreasing Problem can be solved by I.C.I. Trichlorethylene. Already this process has streamlined production for so many metal part manufacturers — may we help you?

Write or 'phone our nearest State Sales Office for full information on vapour degreasing with . . .

## TRICHLORETHYLENE



**IMPERIAL CHEMICAL INDUSTRIES  
OF AUSTRALIA AND NEW ZEALAND LTD.**

## THE ENGINEER'S "IF"

By X. Y. Z. Throgmorton, F.B.E.

If you can hold your liquor in whatsoe'er it is,  
When you see your mate is down, and losing grip on his;  
If you can flirt with umpteen girls and treat them all the same,  
And let each one think she's the lass that's gunna have your name;  
If you can rave and swear like hell when all your bridges crash;  
If you can live on all your friends, and borrow all your cash;  
If with slide rule you can make your answers fit the book,  
And make it seem you're pretty good, e'en though you've had to cook;  
If you can take your staff man out, and level from here to there,  
And come back with a couple of yards or more to spare;  
If you can design a dam or truss that fails quite abruptly,  
Then prove the foreman in the wrong, that he built it most corruptly;  
If, when a youngster calls you Dad, you look quite calm and say:  
"I'm sure I don't know you, you — Who's your mother, pray?"  
If you can do all this, my son, and still pass your third year,  
Well, then you're bound to be, you twirp, a helluvanengineer.

## PARODY ON ED II.

The designer bent across his board,  
Wonderful things in his head were stored,  
And he said, as he rubbed his throbbing bean,  
"How can I make this thing hard to machine?  
If this part here were only straight  
I'm sure the thing would look first rate.  
But 'twould be so easy to turn and bore  
It never would make the machinists sore.  
I'd better put a right angle there,  
Then watch the machinists tear their hair.  
Now I'll put the holes that hold the cap  
Way down here, where they're hard to tap;  
Now this piece won't work, I'll bet a buck,  
For it can't be held in a shoe or chuck.  
It can't be drilled, and it can't be ground,  
In fact, the design is exceedingly sound."  
He looked again, and cried: "At last  
Success is mine. It can't even be cast!"

Ken Lane, Massachusetts.

# THE INSTITUTION OF ENGINEERS, AUSTRALIA

*What it is and what it does.*

The first thing to note is the correct name. It is the "Institution," not the "Institute." The difference of meaning between the two words is not great, but it is, nevertheless, a significant difference, as reference to an authoritative dictionary will reveal.

## EARLY HISTORY

In the early part of this century there existed quite a number of associations and societies representing the various branches of the Engineering profession.

These associations were not strong, either in the number of their members or in their resources and influence.

In 1919 a move was instituted to amalgamate these small associations (some 12 in number) into an Institution of a Federal character. The new body was called The Institution of Engineers, Australia, and immediately upon its formation it assumed the position of the foremost professional body in the Commonwealth, a position which it maintains today.

The constitution of the new body was drawn up with great care and foresight by the most eminent engineers of the day (one of the most prominent of whom was the late Professor Sir Robert Chapman), and upon this very sound foundation The Institution has continued to grow and expand its influence.

By 1938 the membership had grown to such an extent, and the professional status of its members to such a degree, that a Royal Charter was granted to The Institution.

Up till this time there was no way in which a Professional Engineer could have his qualifications and status recognised and distinguished from those of a Tradesman, since the term "engineer" was by common usage applied to both alike.

The granting of the Royal Charter, however, immediately entitled every Corporate Member of The Institution to use the term "Chartered Engineer" after his name.

## MEMBERSHIP

Up till this time the membership had been growing steadily, but since the granting of the Charter the rate of increase has been considerably greater, so that there are today some 12,000 corporate members, making it the strongest professional body in Australia. Membership of the South Australian Division is now approximately 800.

## OBJECTS

The objects of The Institution, as set out in the Constitution, are as follows (in abridged form):

1.—To promote and advance the Science and Practice of Engineering in all its forms.

2.—To raise the character and status of the profession and its members.

3.—To increase the confidence of the community in the employment of recognised engineers by admitting to The Institution only such persons who have satisfied the Council that they have adequate knowledge of the theory and practice of engineering.

4.—To promote honorable professional practice, and suppress malpractice.

5.—To collect and circulate statistics and other information relative to engineering.

6.—To arrange lectures, exhibitions, public meetings, classes, and conferences to advance knowledge and education in engineering.

7.—To encourage the study of engineering and to improve and elevate general technical knowledge; to test by examination the competence of such persons, and to donate prizes, awards, and distinctions, and to institute scholarships.

8.—To disseminate knowledge affecting the profession of engineering.

9.—To discover and make known developments in engineering.

10.—To originate and promote improvements in the law affecting the profession; to improve administration and to petition the Crown or legislative bodies to take steps to further the objects of The Institution.

11.—To promote and safeguard the interests of the profession generally.

The Institution, through the Council and the numerous Headquarters Committees, together with the Division Committees, is constantly taking active steps in all the above objectives.

## ORGANISATION

The Institution has its headquarters in Sydney, where a permanent secretary and administrative staff is employed.

The control of The Institution is vested in a Council of senior members nominated by each of the Divisions—the number of Councillors from each Division being related to their membership.

The great volume of executive work is carried out by a number of committees, operating through headquarters, and responsible to the Council.

Each State, together with Canberra and Newcastle, has its own Division, each one of which largely manages its own affairs through the Division Committee.

The Divisions, in turn, may have within their framework one or more Branches, which arrange their own meetings under the aegis of the Division Committee. The Divisions may also have within their framework various Groups, which look after the needs of members in outlying country areas.

It will be seen that the organisation of The Institution is widespread and comprehensive, and endeavors to give the greatest possible service to its members within the terms of its Charter.

It is interesting to note that the most eminent engineers in Australia are members of The Institution, and give very freely of their time to Institution affairs. They in return derive much from The Institution, and perhaps owe some measure of their eminence to its influence and standing.

There can be little doubt that young engineers who are training for entry into the profession will very soon in their careers derive benefit from membership of The Institution if they set out to do so.

H. S. DEAN,  
Chairman, S.A. Division.

## *The Editor speaks...*

I should like to express my thanks to all the various people who helped so much to make this publication possible.

Mr. Oh, Kong Yew rendered valuable assistance on the editing side.

John Bateup and Bob Bamford handled all the business side—we may even make a small profit—and to get the 24½ pages of advertisements included, contacted at least one hundred firms. This consumed much valuable time and energy.

Our thanks are due to Juris Reinfelds, the official photographer, and to the typistes, Mrs. E. Finlayson, Mrs. J. Town, and Miss Carlein Schrader, who very kindly agreed to type all the material in this magazine.

We have a new cover design this year. It was drawn by Laurence Schneider, and our thanks are due to him.

We should also like to thank the printers, E. J. McAlister & Co., for their very kind treatment of our problems. They have been very courteous and patient, even though this publication has been lying on their tables for many months.

# **H. W. BURGESS (Patternmaker) LTD.**

**180-186 ANGAS STREET, ADELAIDE**

**SOUTH AUSTRALIA'S LEADING PATTERNMAKER**

(Established over 30 years)

CONSULTATIONS ON ALL PATTERN  
MAKING, ENGINEERING, AND  
FOUNDRY PROBLEMS

NO PATTERN TOO SMALL OR TOO LARGE!

*Happy to help at all times!*

**JUST RING W1684 or W1840**

# A DAY AT SURVEY CAMP

As seen by S. Y. Tay.



"Wonder what has wood chopping got to do with Surveying"

Consists of waking up at six in the morning for a bit of healthy fresh air and exercise.



"If this instrument was good enough for Captain Cook, it is good enough for you."

Starting the day by being told off when you complain that you are allotted with a grandfather theodolite.

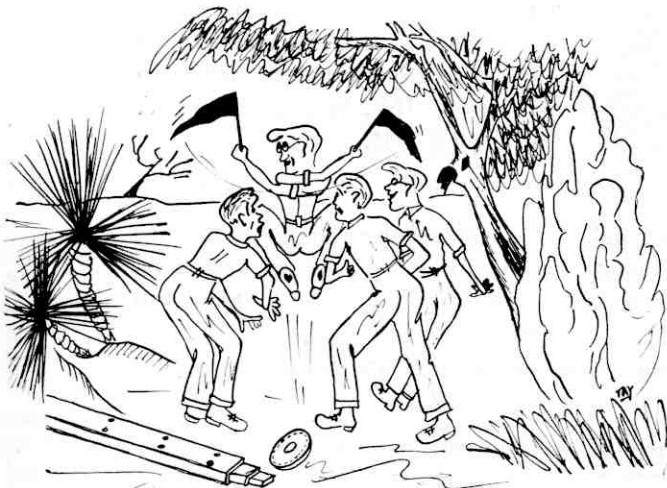

"This means the boss' around. Get up and pretend to work. O.K.P."

Arranging a code of signals to make the day's work easy and safe.



"At least we are being frank about cooking up the results"

Spending the rest of the afternoon leisurely cooking the results.



# You can Depend on



*Pope Industrial Motors  
for Reliability - High  
Performance - Low  
Initial Cost*

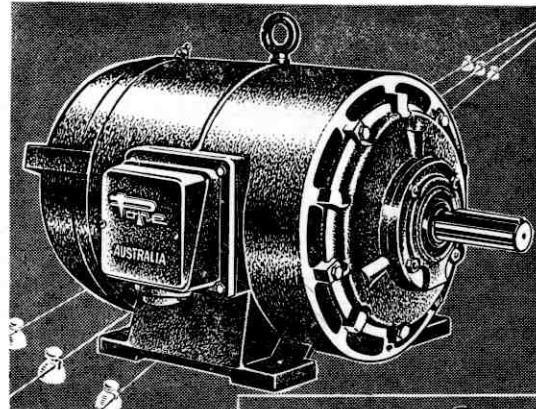

**Totally enclosed fan cooled industrial 3-phase squirrel cage electric motors,  $\frac{1}{2}$  H.P. - 55 H.P.**

Of rugged construction, designed and built for heavy duty, indoor and outdoor application, these motors have been widely accepted for use in the steel and mining industries throughout Australia.

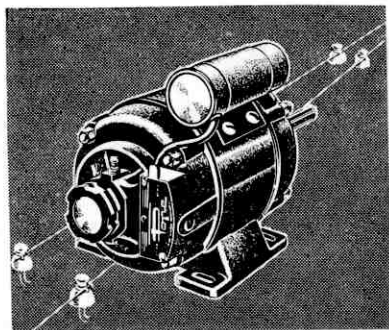
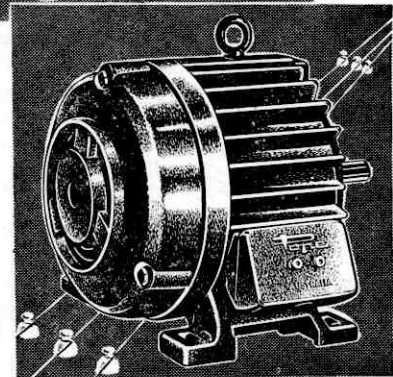

OPEN, DRIP PROOF

Also available—1/4, 1/3, 1/2 H.P. open type in resistance split and capacitor start types, solid foot or resilient base mounted, sleeve or ball bearings.

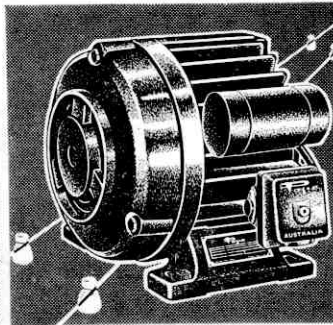

TOTALLY ENCLOSED

Single Phase, totally enclosed fan cooled capacitor start, ball bearings,  $\frac{3}{4}$  H.P. to 1 H.P. 240 V. 1440 R.P.M.

Reliable and quiet in operation these motors offer the highest in quality and performance, and are manufactured to relevant Australian and British Standards Specifications.

Price and dimension sheets available on request.

Enquiries for mechanical and electrical variations should be made at your nearest Pope office or agency.

Manufactured and Guaranteed by

**P O P E P R O D U C T S L I M I T E D**  
PERTH . ADELAIDE . MELBOURNE . SYDNEY . BRISBANE . HOBART

# URANIUM

By R. G. STAKER.

*Some interesting aspects of our atomic age.*

A new element was brought to the notice of chemists in 1789, when Klaproth described the various compounds that he had prepared from pitchblende. He named it after the newly discovered planet, Uranus. Becquerel discovered the radio-activity of uranium over a century later, but the work of Fermi in 1934 began the "atomic era" when he produced radio-active elements by bombarding uranium with atomic particles. Then Hahn and Strassman (1938) made barium from uranium. At first they did not accept these results at face value, but within a few months they had been confirmed by many other investigators—uranium plus slow neutrons equals simpler elements plus energy.

In the few years 1934–9 uranium changed from a by-product of radium production and an interesting source of yellow glazes in the ceramic industry to a strategic material under the strictest security measures.

## Radiation Detectors

Uranium and its minerals are radioactive, and display alpha, beta, and gamma activities. The uranium content is always associated with a series of sixteen elements, which represent the stage-wise disintegration of uranium to lead. All these "daughter" elements are radioactive, and make a very considerable contribution to the observed activity of a uranium mineral.

Beta activity is the emission of electrons of characteristic energy, having a medium range in air, but easily stopped by a thin brass screen. Gamma radiations are short wavelength X-rays of relatively great penetration, being able to pass through several inches of lead, although with reduced intensity. Alpha radiations are helium nuclei, and have very little penetrating power.

All radiations have the ability to ionize a medium through which they pass. The leaves of a charged gold-leaf electroscope are repelled; but a radioactive sample ionizes the air within the electroscope, and the leaves collapse as the charge leaks away. The spinthariscopes has been used to detect alpha rays. This was a screen of zinc sulphide which emitted a flash of light whenever an alpha particle hit it. Such instruments have been the basis of the Geiger-Muller tube and the scintillation counter.

The GM tube is a chamber filled with a low pressure atmosphere of an easily ionized gas (argon) and a powerful electrostatic field, main-

tained by a central anode wire and a cylindrical cathode. Any electron liberated within the counter due to the ionizing action of alpha, beta, or gamma radiation initiates an electrical discharge. This causes a voltage pulse to be registered at the anode. After each discharge the tube is insensitive to any further ionization event until the electrostatic field is re-established, and the atmosphere of the counter has stabilised. This "dead time" limits the rate at which a counter can record ionization events to the order of thousands per second.

The scintillation counter depends on the ability of some solids, when ionized, to emit a flash of light. A crystal of thallium-activated sodium iodide or anthracene may be the sensitive element of such a detector. The light flash is then led to a photo-multiplier tube which converts it to an easily detectable voltage pulse. Since the energy of the incident radiation controls the amount of light produced, radiations of different energies can be distinguished. The time taken for a flash of light to decay sufficiently for the photo-multiplier to detect another limits the counting rate. However, millions per second is a typical maximum.

The GM counter has a very high detection efficiency for beta rays; gamma rays are best detected with a scintillation counter, because they ionize solids more easily than gases.

A recent development in radiation detection has been the crystal conduction counter. Some crystals which are normally poor conductors become conducting when exposed to radiations which ionize the material. Thus, if the crystal is placed in an electric current, a very short duration current flows whenever an emission passes through the crystal. There are serious limitations at present—silver chloride works only at low temperature, and diamonds are expensive—but further research should lead to efficient and easy-to-produce crystal conduction counters.

## Radiation Measurement

Once radioactivity has been detected, instruments are necessary to measure it. The simplest means of registering the individual counts is to feed the voltage pulses to a loud-speaker system. This is commonly used for prospecting and monitoring. All measurements are relative, but sudden changes in the radiation level are easily detected.

The scaler may be compared to an adding machine which automatically records the total number of counts. The input pulses actuate a "decade counter," which counts (and records on a scale) up to ten, and then "carries one." One valve counts units, one tens, one hundreds, and so on. Scalers have wide application in the absolute measurement of activities, especially in research and assay laboratories.

The count-rate-meter shows the actual rate of counting, being similar to a speedometer. Each pulse from the detector sends a standard charge to a condenser, and the rate at which the charge leaks away through a micro-ammeter is a measure of the counting rate. The period over which the instrument averages the count rate is a function of the condenser-ammeter circuit. This factor—usually variable—determines the response of the meter to a change in radiation level.

The further development of the count-rate-meter is a recording instrument which has an important place in air-borne surveys, as it gives data that can be taken back to the drawing office for map-making.

### Prospecting

The detection of outcrops of radioactive minerals (those of thorium and uranium) has been through many stages. The prospector on foot, carrying a GM counter and a loud-speaker unit, has had remarkable luck in finding rich ore bodies—and before him was the traditional prospector with only a crude knowledge of geology. However, both are being replaced by men in jeeps and air-borne scintillometer survey teams.

The only activity recorded by a prospecting team is that due to gamma radiation, because beta rays have only a moderate rate in air. Even gamma radiation is very seriously reduced by any absorber between the source of radiation and the detector. This absorber may be water, soil, barren rock, several hundred feet of air, or thick vegetation. Several feet of rock or six feet of

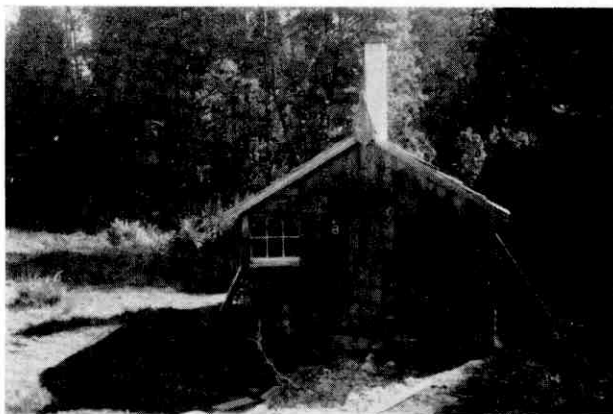

The house that D—— built

water is sufficient to completely blanket any activity of an underlying formation.

Sources of radioactivity may be classified into those due to cosmic rays and radioactive dusts, and those due to uranium and thorium minerals (remembering also the possibility of detecting either potassium or radium). The former represents a background count which is reasonably constant, and must be deducted from the observed readings. The value of this background can be found by taking measurements over at least six feet of water, where the nearest land will contribute little to the count. Fortunately, with a scintillation counter as used in aerial work, the background is low compared to the contribution from the rocks and soil.

There is a second background count that is encountered. This is the general level of activity which corresponds to the surface being traversed. All rocks contain some degree of radioactivity, but it is generally low, and differs according to rock type and location. If a plot of a survey shows an overall value of two (say) units, increases above this will be due to some concentration of active mineral. Such an increase over the average is known as an anomaly.

Concentrations of active minerals occur in three types of system:

- 1.—Localised areas (about 100 sq. ft.).
- 2.—Restricted areas (about 2,000 sq. ft.).
- 3.—Sheet areas.

As the area of a system increases, the contribution that it makes to the observed count increases (assuming a constant grade). This is because the sensitive element of the scintillometer is able to "see" a greater area of active material. This means that a small, rich outcrop or a large, low-grade formation can be the cause of an anomaly. In addition, there is the complication of weathering that may leach away some of the elements that should be contributing to the activity of an outcrop. This means that some allowances have to be made for system areas and grades, and the possible effects of weathering.

As a scintillometer reaches a high altitude the observed count from a point source decreases according to the inverse square law. But at the other extreme, the sheet area is able to present a larger effective radiating surface to the detector, and this tends to compensate for the increased distance between source and detector. As a result, the recorded count due to a sheet area is only effected by the increased adsorption in the intervening air. To distinguish between sheet areas and localised areas, the surveys must be carried out at the minimum altitude that is compatible with safe aviation. By this technique localised areas—which represent a lode of possibly workable ore—cause a much larger count increase than the large deposits of very low-grade material.

# HERCUS

**MACHINE TOOL BUILDERS AND  
RECONDITIONING SPECIALISTS  
ENGINEERS . . . GEAR MANUFACTURERS**

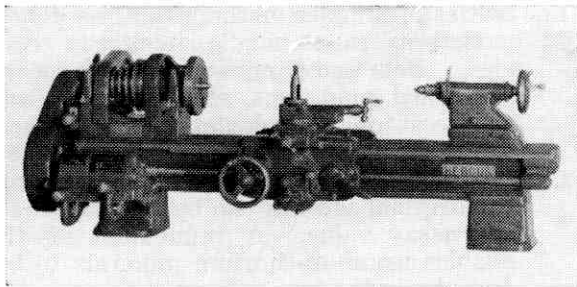

HERCUS 4½-in. CENTRES  
Model A Lathe, as used extensively in labora-  
tories and technical colleges throughout  
Australia.



Machine Tool Selling Agents

McPHERSONS LTD.,  
Adelaide, Melbourne, Brisbane,  
Sydney, Perth.

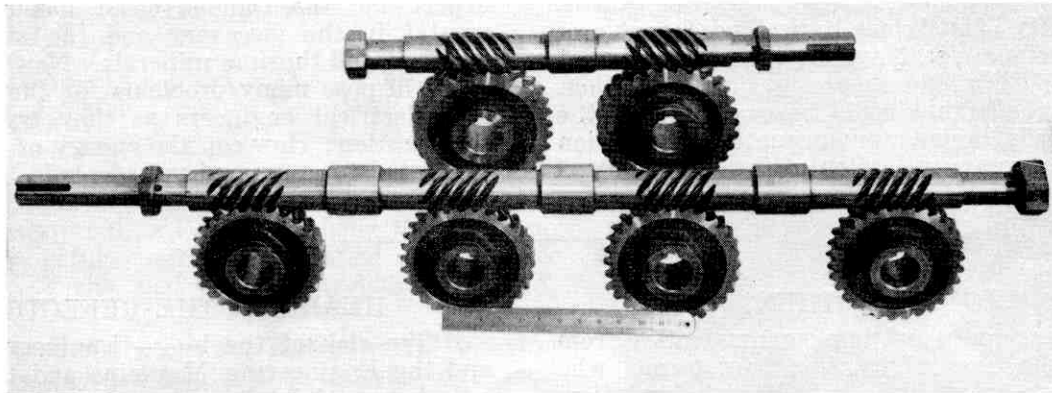

**F. W. HERCUS MANUFACTURING CO. LTD.**

**Anderson Street, Southwark**

**LU 6273**

**LU 6273**



An additional factor involved in the location of an outcrop is the rate at which the scintillometer can respond to the increased count rate. If the recording count-rate-meter has a long averaging time, the effect of a sudden increase in activity arriving at the instrument will be spread over several seconds—corresponding to a slight increase in the recorded count; but if the averaging time is much less, there will be an abrupt increase in the recorded count.

Since these surveys are carried out above the surface, there is another factor introduced by the topography. A decrease in height—relative to the surface—causes an increase in the observed count rate. A radar altimeter may be used to measure the height above ground, and the output from this used to correct the count rate to a standard elevation.

A new idea in aerial prospecting for uranium ores uses a helicopter. Instead of flying on fixed grid-lines according to a rigid system, the pilot is at liberty to fly just above the tree-tops, and to choose his own course. Each likely outcrop can be tested for the possibility of an anomaly, and any find investigated at once, especially when the pilot has an assistant to collect mineral specimens. In this way outcrops of base metal lodes may also be located as an interesting sidelight. To record the flight route, aerial photographs are taken, but there is no permanent record of the activity—the pilot uses a pair of head-phones for rough monitoring, and an ordinary count-rate-meter to get a more accurate idea of the activity level.

#### Assaying

If a chemical assay is imperative, there are many methods available, but most are very tedious. One authority lists sixteen basically different procedures, and his classifications are so broad that all gravimetric methods are grouped together. Typical methods that could be used include the precipitation of ammonium uranate and ignition to the oxide, the examination of the light emitted

by the sample when excited in an electric arc, and methods used on the fluorescent properties and distinctive coloration of some specific uranium compounds.

The most apparent basis of an analytical method is the measurement of beta and gamma activities. But each of these activities is liable to serious depletion by the various processes of weathering. In the most extreme case a chemically leached uranium salt will give no beta or gamma count at all, only the alpha count associated with the uranium. This is because the main activity of a sample of natural uranium is due to the daughter elements. As a result, simple beta or gamma counts can only be used as a rough measure of the uranium and/or thorium content of a mineral.

The "equilibrium" system overcomes the difficulties of simpler methods, and its only limitation is that it cannot handle chemically treated materials. Beta and gamma counts are recorded under controlled conditions, and these two values form the basis of the calculation. Fortunately, there are several simple principles involved in the loss of daughter elements, and by the use of these the original activity can be calculated. This gives the assay value. A refinement of the system enables uranium-thorium minerals to be assayed, and the individual assay values found. Any unusual radium content will also be detected. Such a radiometric assaying system has become very popular, and is able to handle the routine assay load of a metallurgical plant or a research laboratory, provided that no chemical leaching is involved.

The combined knowledge of the electronics expert and the radiophysicist has been instrumental in the discovery and the evaluation of uranium and thorium minerals. Now these minerals will pose many problems for the mechanical and electrical engineers as they try to answer the question: How can the energy of the atom be converted to amps and volts?

#### TOO B— TRUE!

"In essence, a report is a communication from someone who has information to someone who wants to use or ought to have that information. As in all communication, writing a report involves three fundamental elements: the writer, the materials or information to be conveyed, and the reader. It is therefore the writer's obligation and responsibility to see that he writes in **terms and languages which his reader will understand, and to organise his material in a pattern which his reader prefers.**"—Dr. Robert Shunter.

-----  
He only drinks to calm himself  
His steadiness to improve.  
Last night he got so steady  
He couldn't even move!

#### HEARD IN THE REFECTORY

"I'm sick of the b— Engineering Society and the Engineering Magazine and the S.R.C.—let's have a drink."  
-----

Of the 47,000 students who graduated in China in 1954, 15,000 were engineers. In other words, the number of graduating engineers in China in that year was two-thirds that in the U.S.A., five times that in the United Kingdom, and a quarter of that of the U.S.S.R. At the present time 40 per cent. of the University population is specialising in engineering, so that by 1958 China will probably be producing between 25,000 and 30,000 University-trained engineers each year.

"China Trade and Economic Newsletter."

# THE COMMON LECTURER

*A Report specially prepared for A.U.E.S.*

*By A. James J. Dawson (Jnr.), C.B.A., A.U.E.S.L.W.A.*

The lecturer is undoubtedly one of the least understood of Nature's creatures, considered by many to be one of her jokes, made in rather poor taste, it must be admitted.

To date, little organised study of the lecturer's characteristics has been made, and although numerous specimens have been observed throughout the world, their vastly differing behaviour can only have puzzled the casual observer (and most observers are extremely casual). To clarify this highly unsatisfactory position, I, with several equally learned colleagues, formed the first much-needed "lecturer-watching association." Several years' observation has resulted in the following attempt to correlate the facts.

## HISTORY

The origin of the lecturer, as is only to be expected, is lost in the smogs of antiquity. Our only regret is that it was only the origin that was lost.

The earliest known reference to the creature is considered to be found in the Pyramid of Domo-nicles by the noted Prof. B. F. Cow.

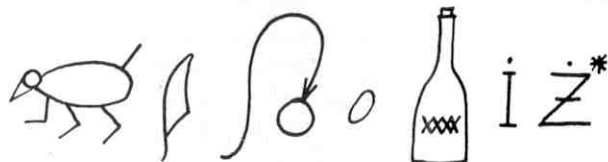

It is obvious that the writer, as the reader has no doubt already ascertained from the crystal clear inscription, was either under the delusion that the lecturer could be classified under homo sapiens, or else had an uncontrollable sense of humour.

An even more elegant and powerful inscription, discovered some time later, tells of Domo-nicles' decision to exterminate the lecturer. As is only too obvious, his laudable efforts must have met with failure.

## PHYSICAL CHARACTERISTICS

The physical characteristics of the lecturer vary more than those of any other creature except, perhaps, the Snowhomo Abominalis Hima-layensis. Size and shape are extremely variable, ranging from the grotesque to the comic, but the following features are common in all.

Lecturers have well-developed hind legs, considered to be due to ceaseless pacing to and fro during their weekly three hours of activity.

Lecturers' heads are a subject of some puzzle-ment. They are also well developed, but appear to serve very little useful purpose.

Most lecturers have a coat of woolly hair, varying in color from blues and greens to the more common browns, though an occasional black and white speckled specimen has been seen. It has long been thought that not all lecturers are opaque, and now at last we can present photo-graphic proof. We of the A.U.E.S.L.W.A. were fortunate enough to find a truly transparent specimen, and are proud to show our unique photograph to any sceptics. This individual, of refractive index 1.4, was carefully studied, and after much deliberation, we were forced to con-clude that his transparency is due to the unusual liquid diet on which he was raised, a substance known by the code letter "p," of chemical com-position  $C_4(NH_2)_2$ .

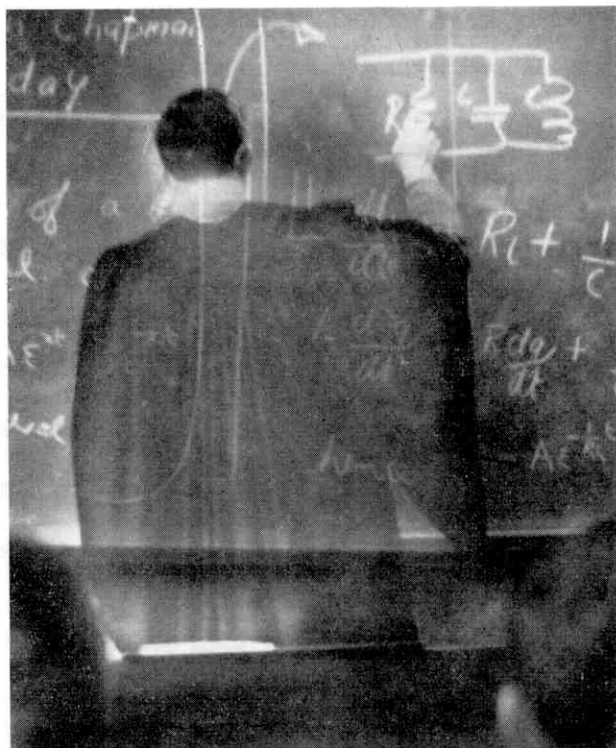

"Lecturers are easy to see through"

The vocal chords of the lecturer are given a phenomenal amount of exercise, with the sounds emitted varying from the clearer tones of youth

through various intermediate stages until the ultimate is reached after many years. This could only be described to the layman as a continuous, monotonous, sonorous drone, but known to the initiated as the Fuller tone. This further degenerates to a series of grunts, whilst one specimen, at present under our observation, emits breathless gasps, mingled with nauseating gurgles. However, he is an olderman, so this is probably due to senile decay.

### BEHAVIOUR

Lecturers are very elusive creatures, emerging from their lairs for a few short hours each week, which explains why their pug marks are not often seen. Those intent on tracking one down are warned that they bear a fierce animosity towards the young (males) of homo sapiens. We find this antagonism quite inexplicable, though it is making itself felt in an organised annual onslaught against us in the Centennial Hall area, which inevitably ends in a victory to the lecturers, with great slaughter. This is thought to be the chief cause of the subsequent anarchist-type reprisals taken against individuals. When the smoke has cleared it is inevitably found that the lecturer has been routed, though some offer great resistance. On a recent glorious occasion a party of beleaguered engineers had to resort to aerial attack, such was the ferocity (and agility) of the blue and grey lecturer that opposed them. One lecturer, whose courage one would expect to be Fuller, flees immediately on attack, as does another who is merely a Burdon to his side.

Lecturers rather resemble monkeys in the strange way they collect unusual things. The blue and grey specimen above mentioned was known to keep a collection of squirrels (the matter was put into the hands of the R.S.P.C.A., as a check of their records should show). Another is extremely fond of bodies of purely arbitrary shape, and has a truly amazing collection. Another monkey-like habit of lecturers is that of imitating humans. For instance, some have been seen attempting to smoke a pipe. This has led to much speculation. . . .

As can be seen, our work is far from complete, as our lecturer-watching years are drawing to a close. To any interested in taking up this noble and worthy pastime, we offer the following information and advice:

1.—Lecturer watching is a subject akin to Refectory I, II, III, IV, and V, in so much as no examination is held. (The reader will no doubt have noticed the subtle omission of Refectory VI, as inclusion of this would imply recognition of medical students.)

2.—Pre-requisite subjects: Leaving teacher-watching.

3.—Necessary qualifications:

- (a) An infinite amount of patience.
- (b) An inexhaustible sense of humour.

A final word to would-be watchers is, don't take yourselves too seriously and you'll survive this University.



## FOR THOROUGH ENGINE OVERHAULS

Whatever the size of the job you want done . . . Angas Engineering's high standards of workmanship are maintained throughout. Every job is fully guaranteed. Ask for a quote.

• Write, phone or call

**ANGAS**  
**ENGINEERING CO. LTD.**  
**THE TRADE MACHINE SHOP**

71-73 Angas Street, Adelaide, W 5274  
 16-18 Moore Street, Adelaide, W 5274

- Chassis straightening and modifying.
- Axle straightening.
- Gear cutting and milling.
- Cylinder reboring and resleeving.
- Cylinder remetal-ling and shaft grinding.
- Line boring and knurl-sizing.

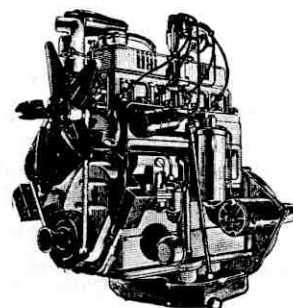
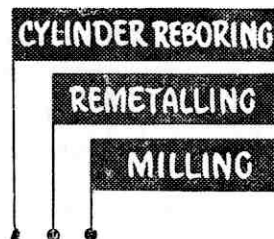

### CHANGE-OVER

Make use of the guaranteed change-over engine range for all popular makes. Change-over con rods and crankshafts, too.

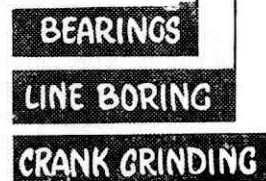



# MET. AND CHEM. DOINGS

*A Chemical Engineer is a man who can explain chemistry to engineers, and engineering to chemists but can't explain engineering to engineers, nor chemistry to chemists.*

## HEAT TRANSFER RESEARCH.

Personnel: Dr. R. W. F. Tait, Mr. T. O. Penman, Mr. R. Staker, Mr. R. J. Kelly, Mr. D. Gunn.

In 1953 Dr. Tait and Mr. (now Dr.) K. J. Cathro commenced research into heat transfer to liquids boiling inside tubes. The main object of this work was, and remains, to elucidate the mechanism by which heat is transferred to liquids boiling inside tubes. As a side issue, it was expected that results useful to the designers and operators of equipment such as boilers, evaporators, etc., would arise. These expectations have been in part realised, but much remains to be done, as only a limited range of operating condi-

tions has so far been covered. With the apparatus formerly available pressures above two atmospheres could not be used. Furthermore, heat fluxes were limited to the range of about 4,000 to 40,000 Btu/(ft<sup>2</sup>)(hr). With the apparatus now being constructed it will be possible to study heat fluxes over the entire range from zero to about 100,000 Btu/(ft<sup>2</sup>)(hr), and pressures up to about 250 psig. This will give results in a region which has not yet been covered, and should form a useful check on correlations already developed. Later it is hoped to extend the work into the region of very high heat fluxes, such as are encountered in nuclear engineering work.

## REACTION KINETICS RESEARCH.

Personnel: Professor E. C. R. Spooner, Mr. J. C. Lill, Mr. I. G. Matthew, Mr. N. S. Gray.

This group's attention has been directed towards the study of solid-gas heterogeneous reactions, with particular attention to the rates of certain reduction reactions. The reduction of alkaline earth sulphates by hydrogen was shown thermodynamically to proceed by means of a single reaction up to 1000°C, thus providing suitable reactions for a kinetic study. After the

necessary preliminary experimental evaluation of the equilibrium constant, the rates of reduction under various conditions in both fixed and fluidised beds were determined and compared.

Concurrently, a similar study on the reduction of lead monoxide and lead sinters by hydrogen is being undertaken. By determining the controlling mechanism for the reduction of pure lead monoxide, it is hoped that the kinetics of the reduction of lead sinter by hydrogen may be more easily understood.

## GAS ABSORPTION RESEARCH

Personnel: Dr. R. V. Culver, Mr. D. Ward.

The ability of charcoals to absorb gases and vapours is well known, and in the course of research work carried out (in this Department), an attempt has been made to correlate the absorptive capacity of a charcoal with its physical properties. Thus, in the case of a specially prepared charcoal, the absorption of the simple components of a hydrocarbon mixture, and exclusion of the

more complex ones, is due to the "sieve" action of the extremely small pores. The present interest lies in the rate at which water vapour is absorbed on a charcoal, and particular attention is being given to the diffusion processes on the surface of the material, as well as within the porous structure. The mass and heat transfer data calculated from the results obtained will form the basis for the design of industrial absorption equipment.

## AMAZEMENT

How to give a girl a surprise. Place your arms around her waist. Draw her strongly toward you, and hold her tight. Start to kiss her. When she says "Stop!" release her. Note the amazement on her face.

## STRENGTH HOMEWORK

So I concentrate my forces,  
Deflect for backward throw,  
And hurl my Timoshenko  
Just as far as it will go.



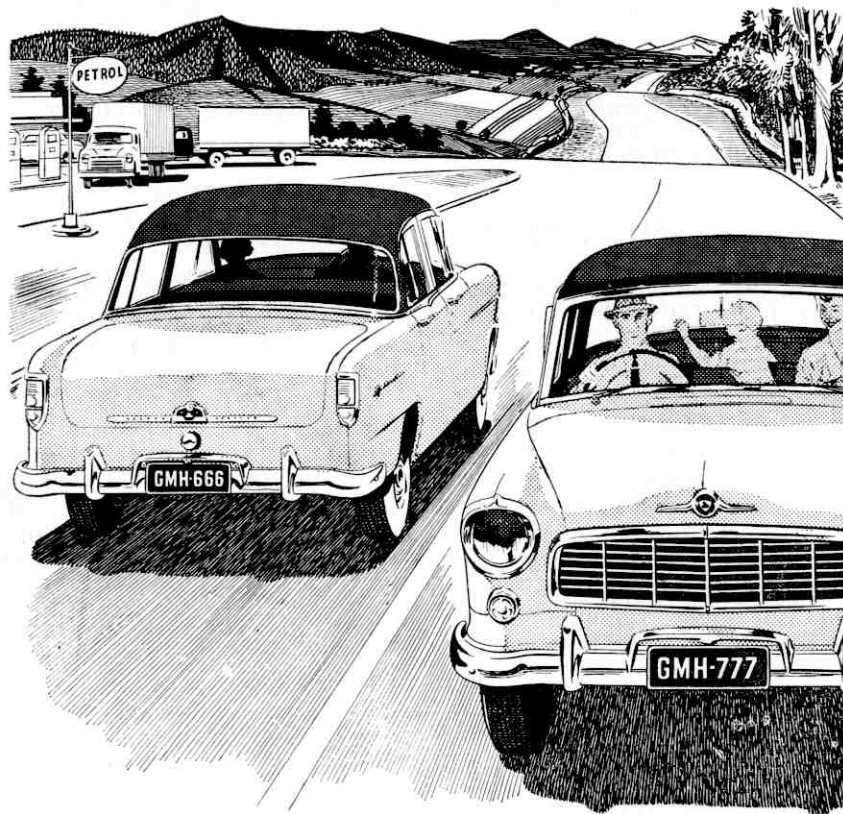

More for your money in style . . .

## **More for your money in action, too !**

More, far more than just lovely to look at, Holden's a thrilling car to drive. For Holden offers you the kind of performance that's ideal for Australian conditions. You have the quiet smoothness of six cylinder power at lowest cost. Hills flatten as though by magic when challenged by Holden's surge of 70 gross brake horsepower—wherever you go Holden performance is there whenever you need it.

You'll find more than simply engine performance in Holden, too. There's the magnificent way Holden's re-circulating ball steering responds to your slightest wish . . . the way its steady ride holds firm and true on the roughest road you travel.

Take a Holden out on the road for yourself, discover the hidden charm of Holden, see for yourself how much more Holden offers you for your money.

*Convenient GMAC hire purchase terms are available.  
There are two "Air Chief" Car Radios specially designed for Holden.*

## **HOLDEN\* — Australia's Own Car**

\*REGD.

From **£910** plus Tax.

B206  
*General Motors-Holden's Limited • Brisbane • Sydney • Melbourne • Adelaide • Perth*

# WHITHER AUTOMATION?

By L. T. SCHNEIDER.

*The Age of Automation is dawning.*

We know that there will be less work to do, and more time for leisure. Will this change ultimately be for better or for worse? It is on the new relationship between work and leisure that I wish to write, since here will lie one of our biggest problems; and it is one that has not yet been much considered.

Firstly, how might we define work and leisure? The answer may at first sight appear obvious, but it is far from being so, and could only find adequate treatment in a book, not an essay. Nevertheless, a brief glance at the way in which the two have been related in the past will be helpful to an understanding of them, and should to some extent indicate the direction of further changes.

When speaking of work in the Mediaeval sense we are at once brought face to face with art. In Mediaeval times there was no real distinction between artist and artisan—both were men who made what needed making—and this, indeed, is the proper definition of the word "artist." And art is simply skill—the skill needed to make things. Whatever else we may say about art—and much has been said about it—it remains skill. And so work which involves skill is really performed by an artist. "The artist is not a special kind of man, but every man is a special kind of artist," writes Ananda Coomaraswamy. But today we talk about the "fine" and the "useful" arts as though they had nothing in common at all; the one may by intention be devoted solely to "beauty," and the other to "use," with beauty as an optional after-thought. In Mediaeval times "to make a toasting-fork was to make a toasting-fork, not a sample of artistic ironwork. To invent a chant for the Mass was to invent a chant for the Mass, not to make a musical composition." (Eric Gill.) Thus "art" as we know it was not thought or talked about.

A thing was—and actually still is—only made in the right way if both useful and beautiful. But it would be simpler to say that an object need only be useful—that is, pleasing to both body and mind, or, with the fine arts, pleasing only to the mind.

What happened in the Renaissance? The artist now becomes a special kind of person, calling himself painter, sculptor, architect, or musician. As a humanist, he consciously begins to "express himself," while the working classes of which he is no longer a part gradually lose their means of self-expression. What happens to the making of ordinary things? Briefly, the competitive system of private capitalism replaces the co-operative craft guilds, and the worker, entering the machine age proper, becomes exploited

for his master's profit and aggrandisement. Financiers now control the making of things; the worker is not so responsible as before. And when the Industrial Revolution comes to a peak in the early nineteenth century, with all its noise, its smoke, its squalor, its congestion and general inefficiency, and—most significant of all—its regimentation and dehumanisation of the worker, the distinction made between artist and worker becomes clear. The more industry progresses, the wider becomes the separation.

Our own day has seen a further development of this process, although, of course, industrial conditions have greatly improved. The artist of to-day has reacted against his machine environment, although he condemns society in its misuse of the machine rather than the machine itself; he is, indeed, more sensitive than other people to the essentially geometric forms of the machine and its products, for he frequently expresses himself in terms of them. He still holds the mirror up to nature, but now it is rather to HIS nature, and so his works are apt to become incomprehensible exercises in psychology.

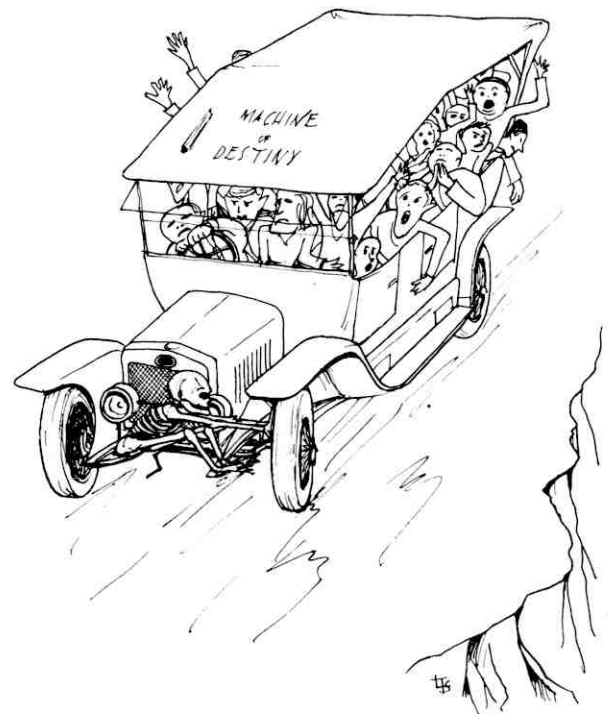

Thus his function has little meaning for society, who understands only its own "leisure" art. But here it should be emphasised that art can still be properly related to the making of things, because all things, however made, must

first exist in the human mind. The difference today is that fewer men are needed to design things, since the machine of necessity standardises the sizes and shapes of things—a characteristic, incidentally, to be welcomed rather than deplored in such a complex age as ours. Realising, then, that the industrial designer is a highly skilled artist, we turn to the worker.

What has become of his skill? Let us admit that the minder of machines in general needs less skill than his predecessor; but let us also note that there has always been dull, mechanical work to be done. And here it would seem that the future is indeed rosy, since automation promises ultimately to eliminate this aspect of work. "Work in the form of unwilling drudgery or of that sedentary routine which . . . the Athenians so properly despised—work in these forms is the true province of machines," writes Lewis Mumford in "Technics and Civilisation." "Instead of reducing human beings to work mechanisms, we can now transfer the main part of the burden to automatic machinery." Thus the worker will have less and less to do with the actual making of things; his skill will be transferred and applied increasingly to the doing of things, such as the mining of raw materials and the growing of food.

But here it is as well to take note of the potential dangers of a totally mechanised civilisation—dangers that have, indeed, already been made painfully apparent. For not only were the two world wars made more terrible by mechanical, machine-made weapons, but they were encouraged by the makers of these deadly toys, and became for countless men a means of self-expression, something denied them in the factory. But it is not only in the sphere of war that the machine has wrought havoc.

For example, to develop an efficient internal combustion engine is one thing, but to assert that a car has value because it is fast is quite another. The real value can only be measured in terms of human purpose, not to some abstract physical quantity; and if the accident rate and traffic congestion increase in proportion as the speed and number of cars on the road, one cannot afford to disregard these factors in assessing the total "progress" made. We may consider labor-saving to be a good thing, and at first sight the machine certainly does appear to save labor, but actually what it saves in one place it often creates in another. A few men with tractors may replace hundreds working with animals; but consider the extra men needed to mine the metal for the tractors, to manufacture, to advertise, to sell, to maintain and service them. Thus the complexity of living goes on increasing, and the total ease of living provided by an age of mechanical gadgets threatens to become cancelled out. It does no good to say that the machine is "advanced"; so is modern warfare. Of course, considered aesthetically, AS WARFARE, this is very good indeed; the atomic bomb is infinitely more effective than any number of wooden arrows, but surely it is unnatural for man to delight in such diabolical advances. All inventions do exhibit

man's technical cleverness and scientific knowledge, it is true; but these do not in themselves guarantee moral improvement.

Furthermore, the machine can never become a substitute for direct organic experience. Art in all forms provides an outlet for creative activity, and if a machine civilisation denies this form of expression to the majority of men in their work, then a compensating form must be found in leisure. The danger with this kind of transfer is that for society, if not for the individual, this energy may be misspent. What we will have continually to bear in mind is the actual capacity and limitation of machines. Wonderful and useful as they may be, as they improve they can but approach a certain limit—but never go beyond it. The machine is a means, not an end. "In the arts," writes Mumford, "the machine can only extend and deepen man's original functions and intuitions. Insofar as the phonograph and the radio do away with the impulse to sing . . . insofar as the automobile does away with the impulse to walk, the machine leads to a loss of function which is but one step away from paralysis . . . the perverse triumph of the machine follows automatically from the abdication of the spirit."

So leisure will no longer be merely "re-creating" one's self—if, indeed, it can be called this today. It will loom large as spare time to be filled in. Will it be difficult to fill? Men will be free to make things—but make what? Few useful objects will need to be made by man; handicrafts will be therefore virtually useless, except as a means of self-expression, and in any case are bound to clash aesthetically with machine-made objects. No; we may well expect new democratic fine art forms to flourish—"abstract" patterns of colour, line, and sound—not all containing much meaning, perhaps, but at least better than pretty pictures of romantic cottages . . . Thus the wheel of art, work, and leisure appears to be turning full circle. We cannot say yet at what rate it will turn, or whether or not it will be thrown off balance in the turning; but we do know that if the machine becomes master of man, it will be because he has allowed it to become so.

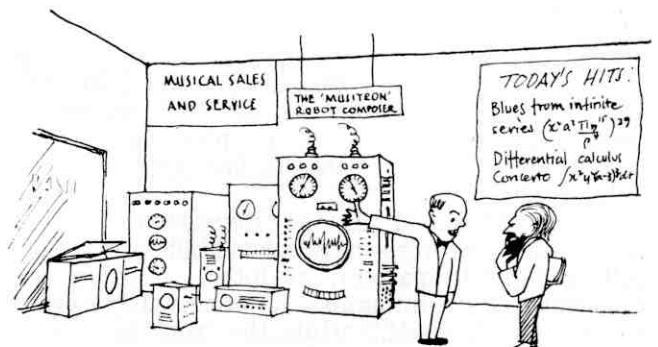

They say that Bach was a mathematical composer, but just think what he could have done with one of these!

# POWER SAVING!

## IS IMPORTANT IN THE SELECTION OF A SUITABLE PUMP

The efficiency of a centrifugal pump is the ratio of the work done by the pump to the power required to drive it, and this important factor is frequently overlooked by purchasers, but is becoming more appreciated due to the high cost of electric power in most country areas.

Take, for example, a pump driven by a 25 h.p. electric motor. A well-designed pump properly applied to the particular job might operate at an efficiency of 80% and cost, say, £150.

Another pump of inferior design might operate at 70% or, if haphazardly applied, at 50% or even less. Such a pump might cost around £100. Assuming that the pump operates for 3 or 4 hours a day on the average and that electric energy costs 4 pence per unit, the purchaser of the pump working at 70% efficiency will have to pay £50 per year more for power than the one who decided on the more efficient job. A proposition that will return its extra cost in power saving over the first year is a worthwhile one indeed.

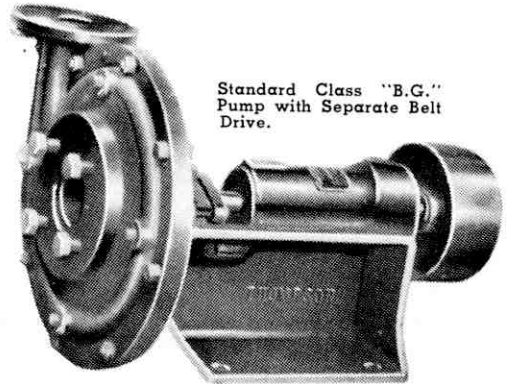

Standard Class "B.G."  
Pump with Separate Belt  
Drive.

CHOOSE WISELY — SELECT . . . .

# THOMPSON

## HIGH EFFICIENCY PUMPS FOR YOUR PROPERTY

You can have utmost confidence in the purchase of Thompson Pumps, choice of competent S.A. Engineers for major Government installations, including:

Mannum/Adelaide	25 pumps totalling	28,300 h.p.	Tod River	5 pumps totalling	1,040 h.p.
Morgan/Whyalla	16 " "	8,000 h.p.	Uley/Wanilla	9 " "	450 h.p.
Loxton	4 " "	2,000 h.p.	Chaffey	3 " "	230 h.p.
Loxton Spray Pumps	180*	2,400 h.p.	. . . and many others, including all sewage pumps operated by them.		
Loveday	4 " "	950 h.p.			
Berri	5 " "	1,650 h.p.			

Private users range from the larger industrial concerns such as I.C.I. using hundreds of pumps, to the small agriculturalist or orchardist with but a single small pump.

Thompson pumps are supplied and installed in South Australia by Newton McLaren Ltd., who carry in stock a very complete range of various types of pumps and who have available competent engineers to select the type most suited for a particular application, give advice regarding installation or to undertake this work.

Contact the S.A. Agents for Thompson Pumps.

# NEWTON McLAREN LIMITED

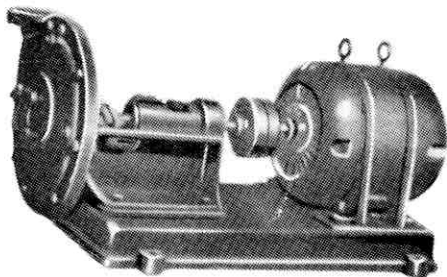

Standard Direct Coupled Class "B.G."  
Pump.

**Engineering Department:**

**75 GILBERT STREET, ADELAIDE**

Telephone: LA 0111



# ENGINEERING FACULTY BUREAU

*What is it, and how can it affect you?*

The purpose of this article is to explain and discuss the aims and organisation of Engineering Faculty Bureau, its activities, and how they can affect the individual student.

For many years Faculty Bureaux have been a well-established part of the activities of overseas national student unions. Just after the last war the National Union of Australian University Students (of which you are all members—4/6 out of your Stat. fee goes to N.U.A.U.S.) attempted to organise similar activities here. Several bureaux struggled for a while, then died a natural death.

In 1953 the question of Faculty Bureaux was again raised. The original aim was to provide productive meetings of students at annual Congress, where matters of particular interest to members of the individual faculties could be discussed.

Since then much thought has been given to Faculty Bureaux by many people, with the result that the following clause appears in N.U.A.U.S. regulations:

- "The functions of Faculty Bureaux shall be:
- "(a) To recommend to N.U.A.U.S. what the policy of N.U.A.U.S. should be upon any particular faculty issue.
  - "(b) To initiate such new activities as may from time to time be deemed desirable, provided that such activities shall not be contrary to this regulation, or to current N.U.A.U.S. policy.
  - "(c) To consider any matters referred to them by N.U.A.U.S.
  - "(d) To present to Council a report of the previous year's activities, and also a statement of policy and proposed activities for the following year."

This clause, then, provides the basis on which each Bureau operates.

Looking at Engineering Faculty Bureau in particular, what is it, and what are its aims?

E.F.B. is purely an administrative organisation with the following aims:

(1) The provision of liaison between students of the Engineering Faculty societies of all Australian Universities, and any overseas engineering student society which wishes to become a corresponding member.

(2) Collection, correlation, and publication of information regarding courses, club activities, local facilities and conditions, cadetships and scholarships.

(3) Publication of a regular newsletter ("Torque").

(4) Organisation of interstate and overseas vacation employment.

(5) Organisation of interstate meetings.

(6) Publication of overseas information and activities likely to be of interest to engineering students.

How can it carry out these aims?

The policies of E.F.B. are largely decided by a meeting of representatives from each constituent club at an annual conference, which is generally held at N.U.A.U.S. Congress.

This conference appoints a new director of the Bureau, editor and managing editor of "Torque," and any other officers which it sees fit. The director's job is to see that policy decided on is carried out, and to report to N.U.A.U.S. Liaison with clubs is carried out by Faculty Bureau officers appointed by the individual clubs.

No organisation can justify its existence unless it can produce results, therefore let us look briefly at what has been achieved, and what is planned for the future.

## Vacation Employment:

(a) Interstate: Lists of interstate jobs and rates of pay have been published in the last two issues of "Torque" each year. This year lists of accommodation available will also be prepared. In addition, if names of students working interstate are forwarded to the F.B.O. of the University concerned, some kind of social activities will probably be arranged.

(b) Overseas: Last year nine Indian students spent their long vacation working in Australia as part of an exchange scheme organised by E.F.B. A delegation of Australian Engineering students was chosen to work in India last year. However, lack of jobs and suitable transport prevented the delegation from leaving.

This year a similar exchange is being organised.

Engineering students at Canterbury University College, New Zealand, have suggested a scheme whereby an exchange of jobs and accommodation between Australia and New Zealand might be arranged. Hence, if all arrangements can be made, students will have a wide choice of vacation employment this year.

## "Torque"

This very popular newsletter is published three times every year. Contributions from any engineering student would be very welcome.

### Chess

Adelaide is at present engaged in a titanic correspondence chess struggle with Melbourne. This competition will probably be extended to the other States.

### Career Brochure:

It is felt that many students leaving school have little or no idea of what an engineering career entails, therefore E.F.B. is publishing a brochure for circulation among matriculation students which, it is hoped, will provide much valuable information.

### Symposia.

During June vacation this year a very successful symposium on "Automation" was organised by Sydney University Engineering Undergraduate Society. About forty engineers from Adelaide, Melbourne, and Brisbane attended. They were billeted in the homes of Sydney engineering students and given a wonderful time. Speakers discussed the technical, social, educational, trade union, economic, and management problems involved in the widespread introduction of automatic control equipment.

Next year E.F.B. has decided to hold a sym-

---

### MACHINE DESIGN

"What does it matter if it can't be made? Nobody is ever likely to try and make it, anyway."

posium on Nuclear Engineering and its associated problems. Adelaide has agreed to convene this symposium.

If we are to do this successfully, the A.U.E.S. will need everyone's co-operation in the organisation of a high-class technical and social programme, and in arranging billets for interstate visitors. If you have some bright ideas, or are prepared to help organise the show, see somebody on the committee as soon as possible.

The chief things that mitigate against the success of E.F.B. are the distances between each University and the limited financial assistance offered by N.U.A.U.S.

The first is the more serious one, since any student project is very apt to collapse unless very close communication can be maintained between the organising personnel. Obviously only a very limited number of personal meetings can be arranged with the limited finance available, hence the future of E.F.B. depends on the enthusiasm of the individual students. One cannot expect the burden of administration to be borne by the devoted few who have seen the Bureau develop out of its napkin stage. It is up to you to make it a success.

K. R. WELLER,  
National E.F.B. Director.

"I want you to know you're the first girl I ever made love to," he said, as he changed gear with his knees.

# W.E.A. BOOKROOM

Western Drive,  
University

W 3211

**A Bookshop within your University  
with a staff trained to help students**

*See us for all your  
Text and Reference Books and Stationery*

**ORDERS FOR BOOKS NOT IMMEDIATELY AVAILABLE WILL BE TAKEN**

# THE BHAKRA-NANGAL PROJECT

By I. J. VIJH.

*This project will turn the dry province of East Punjab into 'the granary' of India.*

Bhakra, recently a small village lying about 250 miles north of Delhi, at the foot of green Shivallack hills, has become world-famous because of a unique dam which is being built there to hold the water of the River Sutlej. The dam, when completed, will be about 700 feet high, and will be the highest pure gravity dam in the world. It is 1,300 feet wide at the bottom, converging to 30 feet at the top. The dam, when complete, will be in the form of a lake which will have a capacity of over seven million acre feet.

Because of its complexity and size, it is one of the toughest jobs being done in the world at present. The magnitude of the work involved may be seen from the fact that about 140 million cubic feet of rock have to be excavated in order to lay the foundations, which are as deep as 180 feet below the surface of the river. The amount of concrete which is to be used is sufficient to build a road 8 feet wide round the world. About 40,000 tons of steel, which will go into the dam, are sufficient to build a railway line 300 miles long.

The Bhakra-Nangal project will wipe out the sad state of things, such as the famine of 1783 in the desert part of Punjab, which wiped out the entire population of the area. In the famine of 1891 over a million cattle perished, and out of this nearly half a million died in one district alone.

A dam of the above size requires many preliminary and subsidiary works, each of them being a project in itself. To begin with, two huge diversion tunnels each 50 feet in diameter, with a length of half a mile, had to be cut through the solid rock so that the river water could be diverted and the dam site exposed for construction purposes. These tunnels are the largest in the world, and took a sum of about £3.5 millions and five years to complete. In addition, two

bridges, a model town for 15,000 workers, and a big workshop were constructed.

Two subsidiary coffer dams were built to protect the dam site from the floods during the monsoon season. The function of the upper stream coffer dam is to divert the water into the tunnels and prevent the water entering into the foundation site. The down-stream coffer dam prevents the water on emergence from the tunnels from getting back into the foundation site. The upper stream coffer dam is 215 feet high, and is the highest rolled fill dam in India.

Concreting is the last phase of construction, and has been taken up recently. In order to provide concrete mixture, a plant covering an area of four square miles has been installed. This plant is the first of its kind in Asia. The belt conveyor, which is four miles long, brings the mixture to the construction site at the rate of 750 tons per hour. The pouring of the concrete will continue day and night for the next three years, and the dam is scheduled to be completed in 1959. The dam, when completed, will be an engineering wonder of the modern world. The latest design techniques of science and the most modern machines have been used in tackling a large number of complex problems, so that the dam will be completed with high speed and efficiency.

Because of this dam, 4,500 miles of irrigation channel will be active throughout the year, serving ten million acres of land in three different States. This means an increase in India's food production of over one million tons.

By the help of four generating plants, 400,000 k.w. of electricity will be produced, which will electrify well over a hundred towns and innumerable villages, besides enabling the starting of many industries. It will also help to rehabilitate two and a half million uprooted refugees from West Pakistan.

When completed, the whole project will have cost about £155 million, but it will turn the dry province, East Punjab, into what may be termed "the granary" of India.

On opening the project, the Prime Minister of India, in a voice quivering with emotion, said: "I look upon these projects, where thousands of human beings are being engaged in a great constructive activity for the benefit of millions of their fellow beings, as temples and places of worship. There are sacred places . . . for me more sacred than temples, gurudwaras (Sikh shrines), and mosques."

This is a glowing tribute to the engineers and men who are working against time and conditions to complete this great project, which means so much to the Indian nation.



Indian Exchange Students

# THROG' IS BACK

*He trudged along, unknowing what he sought,  
and whistled as he went, for lack of thought.*

At last X. Y. Z. Throgmorton, Esq., has returned. The perpetual engineer himself is back with us in person again. We have been told that Throg, fed up with Strength of Materials, went overseas to a Bacchus Society Scholarship to do research in Flolevistics, taking up where Dr. Kaneff left off. We are hoping that he will give us a lunch-time talk on what he found on the Continent. Impossible as it may seem, Throg's wide interests in life have been considerably increased. He is a Master of Arts as well as a Jack of All Trades, but he can't pass Strenz. It is rumored he does brilliantly in the exams, but can't face going to 75 per cent. of lectures.

If you want any advice about your wine, women, and song, or perhaps your course, go and consult Throg—he's always willing to help. He may be found in the Richmond, Queen's Head, Imperial, etc., etc., etc.

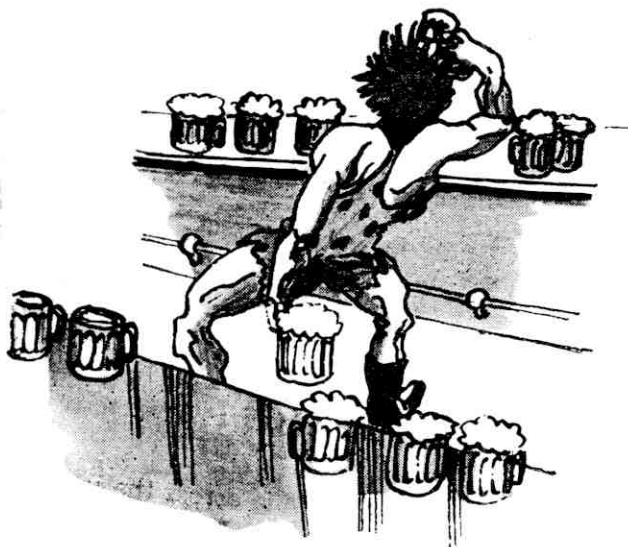

The parallel bars

Those who are early birds may even be lucky enough to see Throg running up and down the scales, strumming through his five finger exercises, and going through his daily dozen at the parallel bars, and all before breakfast, too.

Because Throg is a stranger to most now, after his absence, we feel it is our obligation to reintroduce him, so that you can get acquainted.

1.—BORN: Naturally.

2.—PARENTS: Cannot be located.

3.—PHYSIQUE: Generally sound, but tends to deteriorate after 6 p.m. on occasional evenings.



— MAESTRO THROGMORTON RUNNING UP AND DOWN THE SCALES —

4.—LANGUAGES: English, Australian, and (very) filthy.

5.—ACADEMIC QUALIFICATIONS: Not very many. He tends very often to be slightly confused, for example, at the moment he has art and science slightly mixed up. Despite his natural handicaps, X.Y.Z. is an untiring worker in the cause of the advancement and refinement of higher education in a practical manner, and is vice-Patron of the S.C.I.I.A.E.S.

6.—MUSICAL INTERESTS: Our hero is genuinely interested in all good music, from Bill Haley down to John Bach. X.Y.Z. is fully aware that you can be more efficient with fewer violins, and that woodwinds add timbre to the orchestra, but is under the illusion that an oboe is a tramp.

7.—SPORTS: Contrary to public opinion, Throg shines at all kinds of physical exertion, and every sport.



8.—BAD TRAITS OF CHARACTER: Unfortunately, X.Y.Z. is sometimes inclined to be unreasonably superstitious.



# TECHNICAL BOOK SPECIALISTS



**PRINCIPLES OF D.C. MACHINES, by Langsdorf.**

This standard textbook presents a comprehensive treatment of the fundamental principles of the design and operation of direct current machines.

**INTRODUCTION TO TRANSFER OF HEAT AND MASS, by Eckert.**

Explains the different modes of heat transfer and their relationship to mass. Stresses the conception of boundary layer as the place where most of the conductive heat transfer occurs, as well as the mathematical solution of many heat transfer problems.

**FORMULAE FOR STRESS AND STRAIN, by Roark.**

Here is a compact and readily usable summary of important formulas, facts, and principles pertaining to strength of materials.

**INTRODUCTION TO NUCLEAR ENGINEERING, by Stephenson.**

Designed as a text for senior-graduate courses in nuclear engineering or industrial training courses, this is the first book to bring together the many unique engineering problems encountered in the nuclear energy field.

**ELECTRICAL CIRCUITS, by Harris.**

This book offers the most thorough study of d.c. and low frequency measurements ever published.

**ENGINEERING HYDRAULICS, by Rouse.**

Applications are interpreted in the light of field experience. The net result is intended to give the practising engineer a firm foundation upon which to base his own analysis of problems yet to be encountered.

**TURBOBLOWERS, by Stepanoff.**

Outlines new methods of attack on Turbomachine problems, dealing with the hydrodynamic and thermodynamic aspects of these machines' design. Introduces the concept of the "available energy function."

**UNIT OPERATIONS, by Brown.**

Presents an integrated and complete treatment of the unit operations emphasising the basic principles that are common to different operations.

**ELEMENTARY NUCLEAR THEORY, by Bethe.**

Sets forth compactly the basic theory of nuclear forces, structure, and reactions on an elementary but quantitative level. Based on the familiar results of non-relativistic quantum theory of nuclei, and some of the main ideas of meson theory.

COMPREHENSIVE RANGE OF BOOKS FROM BOTH PUBLISHERS ALWAYS  
IN STOCK

YOU ARE INVITED TO BROWSE OR DISCUSS YOUR TECHNICAL BOOK  
PROBLEMS WITH US AT ANY TIME

PROMPT AND EFFICIENT SERVICE TO ALL YOUR ENQUIRIES

**STANDARD BOOK SUPPLIERS LTD.**

25 KING WILLIAM STREET

COMMERCIAL BANK CHAMBERS, ADELAIDE - - LA 1301

# MECH. DEPARTMENT PROJECTS

*The learn'd is happy nature to explore,  
The fool is happy that he knows no more.*

## THE WATER TUNNEL AND MARINE PROPELLER VIBRATIONS.

Since the beginning of marine screw propulsion about 1860, vibrations caused by the propeller have been a problem facing marine engineers. There are two main types of disturbances from the vibrations—those in the tailshaft and machinery and those induced in the hull by the tailshaft bearing reactions. The first are the more likely to cause serious mechanical failure, while the second may only annoy the passengers.

The major cause of these vibrations is the wake in which the propeller is operating, although rough seas will also cause other vibrations in the hull. It is desirable to operate the propeller astern of the ship in order to recover some of the kinetic energy of the wake for increased propulsion efficiency, and to utilise the effect of the rudder in the propeller race for manoeuvring, and also to protect the propeller from damage. Unfortunately, however, the hull is asymmetric about the propeller shaft, and consequently each propeller blade is subject to an irregular intensity of the wake during each revolution. These conditions give rise to a periodic vibration in axial and torsional loading of the propeller and tailshaft, which is transferred by the tailshaft supports to the hull.

In the beginning, these vibrations were of no great importance, but as speeds, powers, and sizes increased it was found that various reson-

ances in the machinery and hull could be excited. In the event of the exciting force being large enough, a fatigue failure would occur, with possible disastrous consequences. The most common form of such failures occurs when a torsional resonance is excited in the tailshaft. There have been many failures at sea due to this, notably in the war-time Liberty ships.

The first use to which the Adelaide Water Tunnel is being put is the study of a propeller working in an asymmetric flow. A propeller has been installed, together with its driving motor and strain gauge dynamometer. The propeller shaft is carried in air bearings so that there is almost no friction between the propeller and the dynamometer, enabling vibrations which would otherwise be quickly damped out by friction to be measured. The effect of entrained water and loading on the system's natural frequency has been determined, and in future disturbers will be placed in the flow to simulate actual working conditions, and the effect of such parameters as rate of change of wake velocity investigated. The eventual aim would be to investigate methods of flow control in the region of the propeller to reduce the asymmetry and resulting vibratory torque, thrust, and bending loads.

A. E. R. WOOD.

## COMBUSTION STUDIES IN THE PETROL ENGINE.

In the spark ignition internal combustion engine the combustion phenomenon known as "knocking" limits the power output of such engines. Briefly, "knocking" is the rapid self-burning of the last part of the charge to burn, and is commonly known as the autoignition of the "end-gas." Exactly how the end-gas burns is still not known. The type, course, and the cause of the reaction which leads to the rapid burning, and the important intermediate products of combustion which make it possible for this to occur in extremely short time intervals, has been studied by many research workers. This research has been, in the main, directed along two paths, the first a fundamental approach investigating the behaviour of hydrocarbons when burned in air or oxygen, and the second a direct

approach to the mode of burning in the petrol engine itself.

The presence in the Holden laboratory of a Ricardo E.6 variable compression ratio research engine has provided an opportunity to study the characteristic of the pressure rise during the burning of the end-gas. The work to date has shown already that a great variation occurs in the way in which the pressure rises during this period of self-burning. Sometimes a single-stage, and at other times a two-stage pressure build-up, was indicated. Occasionally a severe and sharp-fronted pressure effect, somewhat similar to the pressure wave characteristic of the detonation burning of gases in tubes, was recorded. All such evidence was made possible by the development of a special pressure pick-up of high frequency

response and isolated from unwanted mechanical vibration. This pick-up passed a signal to a cathode ray oscillograph. The trace on the face of the screen could then be observed visually, or recorded photographically by means of a specially developed drum camera. The work is continuing to perfect the pressure pick-up, and to

gain a clearer idea of the mechanism involved in the burning of the end-gas. Such knowledge could eventually help to solve the problem of optimum engine design by allowing the best use to be made of fuels available. At present maximum engine efficiency is limited by "detonation."  
R. G. BARDEN.

## VEHICLE STABILITY AND RIDE CONTROL.

Perhaps the most appealing feature of the motor vehicle is its versatility, and this very attraction imposes a tremendous task on the suspension, which must accommodate a wide range of operating conditions in speed, load, and road surface.

Satisfactory operation of the vehicle suspension concerns two important factors of "stability" and "ride," and although these depend largely on driver reaction, much can be done to reduce this dependence. Stability is essentially a dynamic effect, and demands, firstly, that the vehicle travel along the path desired by the driver, and secondly, that roll does not disrupt the static equilibrium. By careful design of suspension geometry a beneficial amount of inherent stability may be achieved, but this can be effective only as long as the tyres maintain contact with the road. "Ride" rather loosely describes the effect of vehicle motion on passengers, and is mainly concerned with body "action" and frequency. Experience has shown that a flat ride is most acceptable, and this may be closely approached by careful selection of spring rate and inertia distributions.

The suspension is dynamically an extremely complex system, as it has numerous degrees of freedom, which are coupled in obscure ways. There are, however, two motions of great importance—the primary or body motions, which seriously affect passenger comfort, and the secondary motions of the unsprung mass, which influences road-holding. The first is essentially a motion of the body on the suspension spring, while the second is a vibration of the unsprung mass on

the tyre springs. Both of these motions are controlled by "shock absorbers" or dampers situated between the sprung and unsprung masses.

A torsional mechanical analogue has been constructed in the Holden laboratory, which represents a simplified independently sprung wheel and body. Excitation, either sinusoidal or step function, is available to simulate road surface profile. The characteristics of analogue suspension spring and damper, a magnetic liquid unit, may be adjusted within a wide range, enabling the most desirable features of suspension components to be established. Early experiments have been concerned with the action of dampers on suspension performance, and indicate that considerable variation is possible by change in shape of the "work diagram." Future experiments will concentrate on non-linear spring characteristics and combinations of both.

An experimental trailer has also been constructed to allow theories established on the analogue to be checked under actual road conditions. A recording accelerometer has been used on this trailer in runs over prepared track to compare experimental magnetic fluid and commercial hydraulic dampers. It will later be used with non-linear springs and damper characteristics, as suggested by the analogue.

The need for a more exact knowledge of the desirable characteristics of suspensions is well appreciated, and the present research programme is seeking to rationalise the problem.

R. W. SMYTH.

## PRODUCTION RESEARCH INTRODUCES THE 3M "PG" WHEEL

The 3M "PG" (Polishing and Grinding) Wheel is the result of most intensive research by one of America's leading companies in the abrasive field. It consists of hundreds of pieces of cloth-coated abrasive, factory-formed into a wheel that can be used on rotary or straight line automatics, or on standard lathes for hand polishing operations.

Some of the major advantages of the wheel include:

- (a) Greatly reduced down-time on automatic equipment, since some wheels have run continuously for as long as six shifts;
- (b) The space and time for operating a set-up wheel department is eliminated;
- (c) The "PG" wheel is cleaner than a buffing operation, since it uses oil instead of a compound;
- (d) The wheel remains sharp throughout its life,

because fresh mineral grain is constantly exposed as the wheel wears;

- (e) The wheel is adaptable to hand or automatic operations, and will take the shape of the part being polished. The shape will remain constant during the life of the wheel.

The 3M "PG" wheel performs all the jobs hitherto done by set-up wheels, rag buffs, or brushes, yet also removes stock if desired—features which no other abrasive construction on the market today can equal. Its production life is almost unbelievable.

Wheels range in size from 6 in. to 18 in. in diameter.

Further details and information are obtainable from Minnesota Mining and Manufacturing (Australia) Pty. Limited, St. Marys, N.S.W., which is manufacturing and marketing the "PG" wheel in Australia. The company's South Australian branch sales office is situated at Cnr. Rose and Newmarket Streets, Adelaide.

The two divinest things this world has got:

A lovely woman in a rural spot.

—Leigh Hunt.

If anyone has found how to mix women and engineering successfully, for Pete's sake, publicise it!



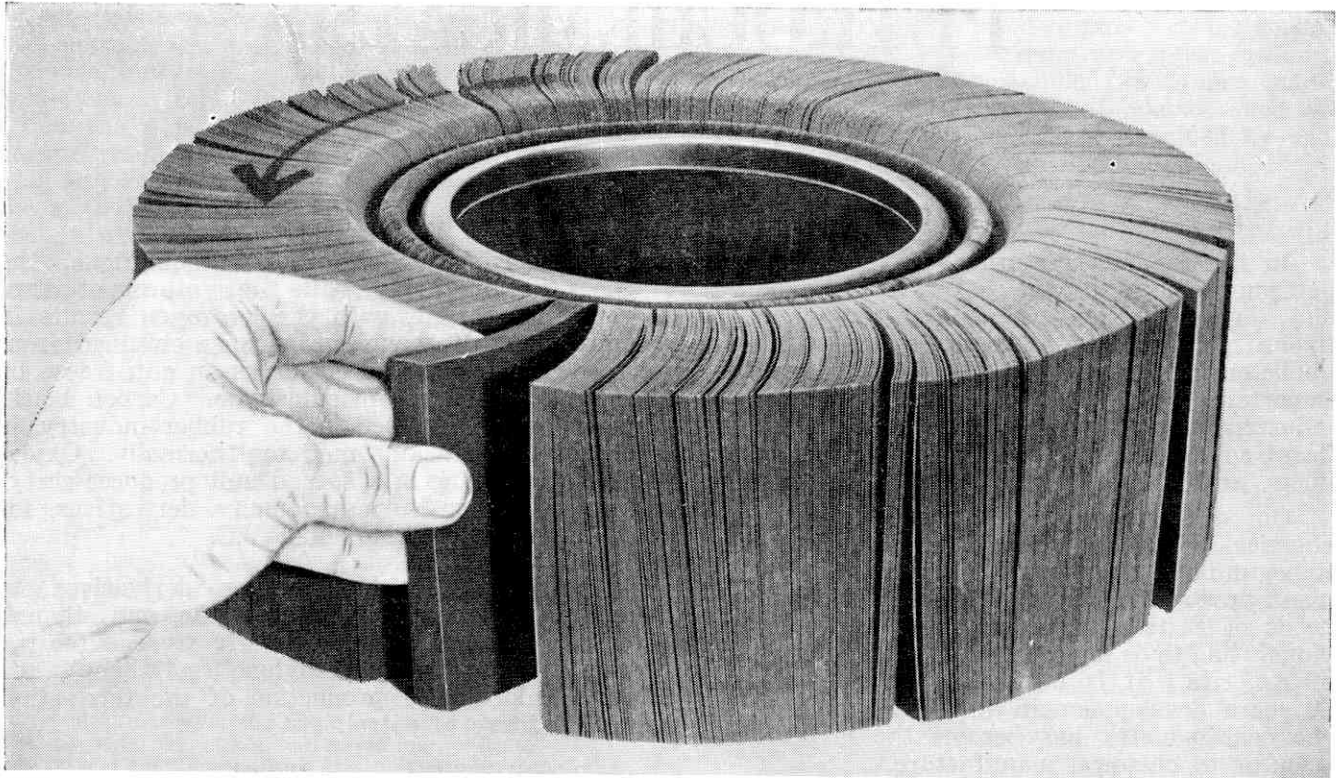

# Now! 3M Introduces the "PG" Wheel

**Obsoletes all other known methods for polishing and buffing contoured and flat surfaces prior to plating or painting.**

**For metal and woodworking applications.**

The amazing new "PG" Wheel is a revolutionary new concept in coated abrasives application—the most significant development in the polishing field in the last 15 years. It reduces costs, increases production, improves finishes.

The "PG" Wheel—formed of over 1,000 segments of cloth-backed 3M Coated Abrasive—is self conforming and retains its shape throughout its working life. It requires no "breaking in" or dressing. It performs all the jobs formerly done by such methods as set-up wheels, sisal buffs and rag buffs, yet also removes stock if desired—features which no other coated abrasive on the market today can equal.

For further information forward coupon to the 3M Sales Office in your State (see below).

● The 3M "PG" Wheel is designed with special alloy side flanges to give maximum strength and safety to the assembly. These side flanges are 8" in diameter and can be used on "PG" Wheels of 12", 14" and 16" diameters. The interchangeability of these flanges allows new loadings to be put into operation wherever it is necessary to use the variety of diameters listed above. The 3M "PG" Wheel is available in a grit range from 150 to 320 (inclusive) and can be supplied in both metal-working and wood-working abrasive cloths.

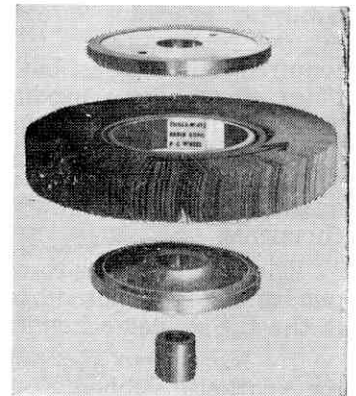

PRODUCT OF  
**3M**  
RESEARCH

*Made by Minnesota Mining and Manufacturing (Australia) Pty. Limited, St. Marys, N.S.W.*

**3M Sales Offices:**

**SOUTH AUSTRALIA:** Cnr. Rose and Newmarket Streets, Adelaide. LA 3702.

Minnesota Mining and Manufacturing (Australia) Pty. Ltd.  
Please send me full information on the 3M "PG" Wheel.

Name

Company

Address

M79PG.



# PETROCHEMICALS

By G. N. WALTON.

*What are they?*

In the far-flung nature of its operation and determination to provide service on the newest and farthest frontier, the oil industry can be likened to only one other utility, that being a public one, the Post Office. Oil is not only vitally important to Australia today, but its place in the industrial structure will become even more significant as new uses are found for petroleum products, and new petroleum products are devised.

One of these new industries, the petroleum chemical or "petrochemical" industry has recently begun large-scale production in England. This plant produces a range of chemicals to suit the needs of British industry, many of which previously had to be imported from the United States of America. It is interesting to note that in 30 years' development in the U.S., the petroleum chemical industry has become the largest contributor to chemical manufacture.

With the development of the automobile and aeroplane, new fuels had to be developed containing the lighter hydrocarbon fractions. Insufficient was gained from straight distillation, so a catalytic cracking process was devised. The heavier fractions were thus broken down into the required lighter ones, but in doing so great quantities of gas were produced, which were of no economic return other than as a fuel. By collaboration between petroleum and chemical scientists these gases were found to be of sufficient quality to act as raw materials for organic chemicals.

The range of uses to which petrochemicals are put can be appreciated by the following. In 1953 in the U.S.A. petrochemicals accounted for:

- 1.—More than 75% of the nation's butadiene for synthetic rubber.
- 2.—14-19% of its plastics.
- 3.—77% of all synthetic detergents.
- 4.—About 50% of all nitrogen for fertiliser, and 70% of all ammonia.
- 5.—13% of all synthetic fibres.
- 6.—Around 30% of the pesticide chemicals.
- 7.—Solvents used in 84% of dry cleaning plants.
- 8.—50% of all sausage skins.

The gases resulting from refinery processes are classified according to the number of carbon atoms in the radical, e.g., methane ( $\text{CH}_4$ )— $\text{C}_1$ , ethylene ( $\text{C}_2\text{H}_6$ )— $\text{C}_2$ , etc. By cracking of methane, the synthesis gas  $\text{CO}$  and  $\text{H}_2$  (water gas) is formed, from which two important chemicals—ammonia and methanol—are obtained. By

resynthesising under different conditions, the gases form methanol, while the synthesis of nitrogen from the air with the hydrogen results in ammonia. Methanol, previously obtained from wood alcohol, is used either as an anti-freeze or for conversion to formaldehyde. Carbon black, which is mostly used in the rubber industry, is obtained by cracking methane thermally. Oxidation of methane in a special unit produces acetylene, which in turn has many derivatives, including vinyl chloride and P.V.C.

Ethylene,  $\text{C}_2$ , has similar derivatives to methane in acetaldehyde, acetylene, and ethanol, but its more important ones are styrene for the plastics industry, polyethylene (polythene), and ethyl chloride for production of the tetra-ethyl lead additive to petrol.

Propylene,  $\text{C}_3$ , is a still heavier gas, which has its most important derivative in isopropyl alcohol. IPA is the starting point of a family of solvents, including acetone, which are used in the extraction of drugs from vegetables and animal matter, as raw materials in the production of resins, perfumes, food flavors, and nitro-cellulose lacquers. As propylene may produce high molecular weight products by polymerization, a propylene tetramer is used to produce the alkyl aryl detergents used so much domestically.

The polymers of the  $\text{C}_4$  olefins act as raw materials for synthetic rubber, of which butadiene is the principal component.

The aromatics,  $\text{C}_6$ — $\text{C}_8$ , are used in the production of benzene, toluene, and xylene, and an Australian petrochemical plant in Sydney is now producing basic feed stocks of the above materials. By oxidation of the aromatics, phthalic acids are formed, which play an important role in the production of the synthetic fibre, terylene. Cyclohexane, a derivative of benzene, is used as an intermediate in the production of nylon and other synthetic fibres.

Of particular concern to the fairer sex, modern nail varnishes were developed from nitrocellulose, a powerful explosive used in World War I, which is now produced on a small scale from petroleum. To this rather startling original source material chemists began adding various petrochemicals to improve the finished product. Important innovations have been the development of oil based plasticizers, which prevent varnish chipping and flaking, and oil based resins, which make the varnish more adhesive and illustrious.

The mere nature of the many products gives the petrochemical industry a potential unsurpassable, and its effect upon other industries has already been felt. Synthetic rubber has had to fill in the gap between demand and supply of natural rubber, and because of its relative cheapness and ready supply, we can expect that over the next decade it will replace the natural product in many fields. Synthetic fibres are finding increasing popularity in many fields previously monopolised by wool, cotton, silk, and hemp. There are few civilised people who have not already experienced the benefits of nylon shirts,

dresses, and stockings, and similar terylene goods. Ropes of nylon and terylene are much cleaner, lighter, and easier to handle than those made from hemp. Healthy living standards, such as we know today, can only be maintained by use of petrochemical pesticides and insecticides.

Modern civilisation is continually calling for new products, and the petrochemical industry will always be at hand with such demands.

(Acknowledgments: Petroleum Information Bureau, Melbourne; Shell Chemical (Aust.) Pty. Ltd., Adelaide.)

---

## X-RAYS PIERCE PROBLEMS IN ATOMIC RESEARCH

X-ray analysis is helping to solve research problems for over 1,000 scientists, engineers, technicians, and administrative personnel working in atomic energy at North American Aviation's Atomics International Division, Canoga Park, California.

In quality control and identification of stock materials such as stainless steels, silver-platinum alloys, solders, brasses and aluminium alloys, the X-ray spectrograph has been used. This instrument is also utilised by the company for analysing ores of uranium and thorium to determine which rare elements might be present; in a recent case the presence of rubidium was noted. In the same manner, deposits in wool filters used at the outlets of experimental vacuum systems are analysed to recover valuable materials that might otherwise tend to be overlooked.

A typical case in which the X-ray spectrograph was used to make quantitative determinations was with uranium in thorium base alloys. Most of the samples for this work weighed about 1.0 milligram, and analyses were completed in several minutes.

For specific research tasks, some members of the analytical and general chemistry group carried out a set of experiments with solid specimen mounts which were designed to fit into the standard holder provided with the X-ray Spectrograph. Of the 40 or so materials tested, the best holders found for milligram-quantities were plaster of paris, fused potassium sulphate, cellulose acetate fiber tape, and titanium metal. Samples may be mounted either directly on the surface or in small depressions made in the surface, depending on the holder material selected.

Aqueous solutions for X-ray analyses are favoured because solutions fit in well with analytical chemical methods, and samples may be transferred directly to the chemical analysts subsequent to X-ray investigation. A further reason for aqueous methods is that many elements which would interfere with a particular search may be removed prior to X-ray fluorescence tests without making it necessary to employ drying methods.

An example of one of these liquid analyses pertained to a bismuth-lead alloy which was under study as a potential reactor coolant. This alloy melts at slightly less than 100 C., and is therefore liquid at high temperatures. Studies of this coolant were made with the spectrograph apparatus to determine what effect the bismuth-lead alloy would have on pipes through which it would be flowing.

Another phase of research in atomic energy at Atomics International is performed by the Solid State Physics Group. Studies undertaken by this research section include atomic radiation effects on metals, graphite, and certain ceramics. Some of the work covers changes in the atomic arrangement (radiation damage) that take place in copper, gold zirconium, uranium, aluminium, iron, and alloys of these metals.

A practical application for information of this type is involved in the design of nuclear reactors. Graphite is an important moderator material, and experience has shown that graphite may be deformed by nuclear radiation. This deformation often tends to produce binding of the graphite control rods in the reactor. X-ray analysis is helping to reveal the factors which affect the rate of damage to the graphite in such nuclear power generators. It is now known that radiation causes the crystal lattice of graphite to expand several per cent., and that thermal annealing can reduce expansion.

The Solid State Physics Group is involved also in line shape studies as related to thorium and uranium. In this work, particle size and strains in the material caused by cold-work or radiation damage are under investigation. These effects are directly indicated on X-ray diffraction charts by broadening of the lines characteristic of the atomic planes which are involved in this damage or cold-work strain.

Single crystal research currently is connected with such metals as copper, aluminium, and uranium, while preferred orientation studies are directed to thorium, copper, uranium, and titanium.

---

It's on the record that a well-known golfer, losing his temper a bit one day, shouted at a friend:

"Shut up! You'll drive me out of my mind!"

"That wouldn't be a drive, it would be a putt," his friend replied calmly.

---

Overheard on a bus on its way to the city one morning.

"Beg pardon, but aren't you one of the Engineering students?"

"Nah. I just couldn't find my belt this morning, my razor blades were used up, and a bus ran over my hat."



# Serve the World

## IN X-RAY DIFFRACTION APPARATUS

Technical excellence, operative flexibility are two of the features that have built for Philips X-Ray Diffraction Apparatus an unsurpassed reputation throughout the world. It is this reputation, together with the vast facilities for research that only Philips can command, that is your assurance of the quality and accuracy of your Philips X-Ray Diffraction Unit.

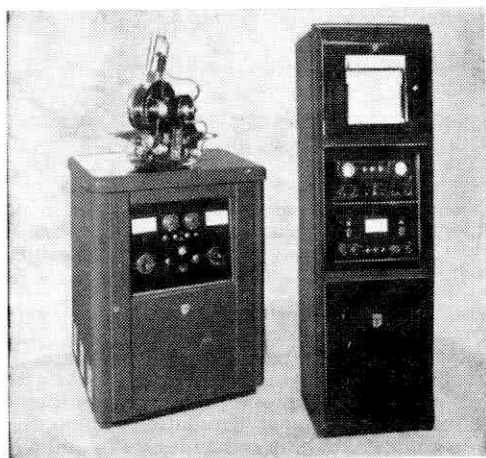

### PW1010

- Smoothed D.C. generator.
- Perfected high-tension and tube-current stabilisation.
- Fully automatic operation.
- Diffraction tube can be used in vertical or horizontal position.
- Large table top.
- Especially designed for work with X-Ray Diffractometer and Spectrometer.

### PW11704

- Small dimensions.
- Alternating voltage generator.
- Filament-current stabilisation.
- Very easy to operate.

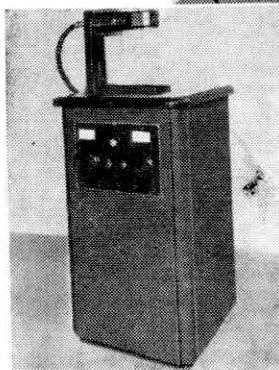
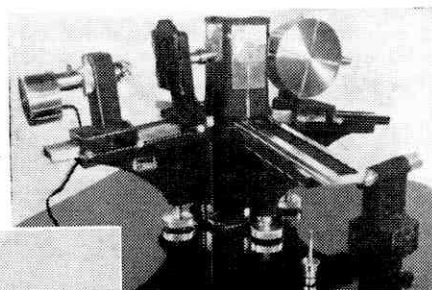
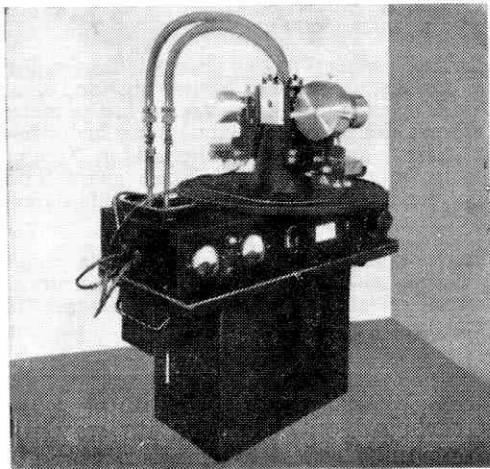

### PW1009

- Smoothed D.C.
- Tube-current stabilisation.
- Semi-automatic operation.
- Large table top.
- Wide selection of cameras.

PHILIPS ELECTRICAL INDUSTRIES PTY. LIMITED

SYDNEY • MELBOURNE • BRISBANE • ADELAIDE

PERTH • HOBART

PG7.57



# TIN DREDGING IN MALAYA

By K. KANDIAH.

*Tin must have been one of the earliest metals which man learned to apply to his economic use. At least 4,000 years ago we knew not only how to obtain tin but also how to smelt it and alloy it with copper to make bronze.*

The earliest known specimen of an article made of tin which is still in existence is in the Achmolean Museum at Oxford, England. This is a pilgrim bottle made entirely of tin, and identified as belonging to the Egyptian 18th Dynasty (1580-1350 B.C.).

The use of tin has multiplied through the ages until at the present time it is essential in the manufacture of household articles in almost every home.

In 1879 the development of tin mining received a strong impetus when technical improvements in the production of tin plating caused a rapid growth in the demand for tin by both the United States of America and the United Kingdom. In the 1880's Europeans entered the tin mining industry in Malaya, bringing with them new techniques and mechanical devices. Some of the early European ventures failed, as the method employed proved unsuitable to the country; others, however, were successful, and some of the mining properties developed at that time are still being worked.

From 1912, bucket dredges were installed in Malaya. The success of this method of mining increased the flow of overseas capital into the industry.

Malayan alluvial tin deposits offer wide possibilities for the use of dredges. Because of the low operating cost of a dredge, much ground with a low tin ore content can be mined at a reasonable profit. On the other hand, the capital cost of a modern dredge and its ancillaries, buildings, etc., is very high, and the available tin-bearing area must be large in order to justify the outlay.

A mining dredge consists of a mechanical excavator and a screening and washing plant mounted on a floating barge. It performs four operations: (1) excavation of the placer ore; (2) screening of the excavated material; (3) treatment of the fine fraction to recover the metallic ores by use of jigs; and (4) rejection of the tailings to the rear of the dredge, and transfer of the recovered ore from the dredge to the treating unit on shore.

At present there are about 80 dredges operating in Malaya. The size and capacity of these plants vary considerably. There are the small dredges, each handling about 200 tons of

soil per hour, and digging to a depth of 30 feet below water level, whilst the biggest dredges excavate more than 1,000 tons per hour, and can dig to a depth of around 135 feet below the surface of the paddock in which they float. In between these extremes there are others, and all are "tailored" to suit the particular property on which they operate.

Like all mining propositions, every area has its own peculiar problems and conditions. Before an area is equipped it is thoroughly prospected by close boring, and the following information is available to the dredge designer: (a) output required to ensure an economic return; (b) maximum depth at which plant is to operate; (c) presence of any barren overburden; and (d) type of ground likely to be encountered.

The size of the dredge is governed by the amount of ground available and the yardage to be treated over a given period, and the maximum digging depth required. If there is a definite barren strata overlying the wash, it is usual to equip the dredge with some means of by-passing the treatment plant in order to facilitate the digging and disposal of the overburden. The overburden is stripped ahead about 30 feet, after which the dredge drops back to dig and treat the underlying ground. During the stripping operation, which may take place two or three times a week, maintenance work is carried out on the treatment plant and other equipment not in use, and this has a good effect on the overall running efficiency.

The type of ground to be dug and treated has a bearing on the design of the dredge. Stiff tough ground naturally requires more power to dig and break up than does sand and gravel. A property with a lot of free sand usually requires more jigging area in the treatment plant. There are few dredges in Malaya digging ground in which the tin concentrates are found in stiff clay. This calls for a special clay treating plant to break up and puddle the clay before passing it through the treatment plant. The power required on these "clay treating" dredges is about double that installed on a plant digging and treating free ground. Another problem associated with clay treating plant is the disposal of the slurry created by breaking up the clay.



The majority of the dredges in Malaya are operated by electricity from an external supply. Some dredges are too far away from power lines to use public utility supply, and various prime movers are used, i.e., steam engines in most instances, with either coal, oil, or wood-fired boilers, and also a few diesel-driven or diesel-electric units.

Electricity makes for a neat arrangement of controls, leaves more room on the deck, and dispenses with the need of regular shut-downs for boiler cleaning and inspection or diesel overhauls. On those dredges using other than electricity as prime movers, the subject of fuel has caused concern since the war. On some dredges the type of fuel has been changed several times. This was made necessary by an acute shortage of locally won coal, brought about by the exploitation of the collieries during the Japanese occupation period, without any thought or planning for the future. The operators of the few dredges burning firewood have, in recent years, had difficulty in obtaining supplies because of the security restrictions placed on the movement of wood cutters who previously cut firewood deep in the jungle. The difficulty of fuel supply added considerably to the problem of dredging concerns.

In addition to the problem caused by the shortage of fuel, there is also the problem of supplying comparatively clean water to the dredge paddock, and the disposal of slime-laden water.

Local interested departments have laid down rigid rules on the maximum amount of slime allowed to pass into rivers or streams.

Consideration has been given to using floating pipelines for bringing clean water from a source remote from the dredge paddock, but always the inconvenience of manoeuvring the dredge, and, to a less degree, the difficulty in keeping the external supply up to the dredge as it moves ahead, has ruled out this possibility.

Malaya is normally well supplied by rain—too well at some periods of the year—but there are times when minor droughts are experienced. Then the problem of mines away from large rivers is usually acute. The normal method of keeping the dredge paddock comparatively clean is to use a slime-pumping outfit mounted on a pontoon moored to the side of the paddock.

The basic design of dredges working alluvial deposits has changed little over the years, but the capacity and efficiency of the present-day dredge has increased so much that many areas previously considered absolutely unpayable are now being satisfactorily worked. Today more than 50 per cent. of the tin output in Malaya is obtained by dredging method, and it is the tin mining industry which has led to the emergence of Malaya from a sparsely populated land of swamps and jungles to its present position as the country with the highest standard of living in South-East Asia.

**Your transmission inquiries are welcomed . . .**

## **CHAINS & ACCESSORIES LTD.**

(ASSOCIATE COMPANY OF AUSTRAL ELEVATOR CO. LTD.)

142 HINDLEY STREET,  
ADELAIDE — LA 3458

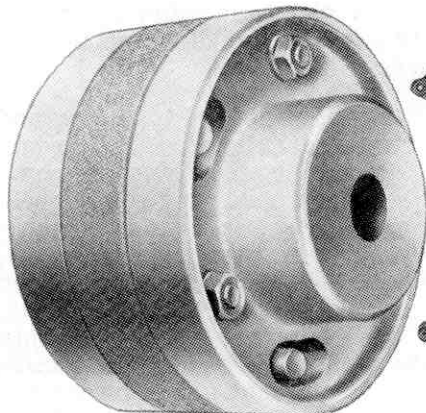

**CHAINS  
CHAIN WHEELS  
SPROCKETS  
FLEXIBLE DISC COUPLINGS  
WORM DRIVES  
CLUTCHES**

40 years of engineering transmission experience at your service. See or contact us for all your power transmission supplies.

AECO  
Flexible  
Disc  
Coupling.



Maximum  
Capacity  
600 H.P.

# LIFE AT AN OIL REFINERY

By "GLOBULE".

*A guide for the intending visitor.*

Samuel Johnson once said: "Prudence keeps life safe, but does not often make it happy." Interstate vacational employment, taken with this thought in mind, can prove to be of great value, not only financially and educationally, but philosophically as well. My purpose, then, in writing this article is not to give you a technical account of the Kwinana Oil Refinery, where I was employed during last vacation. This subject is amply covered in many technical journals, and anything I might say would be mere repetition. What I consider more useful is a "guide for the intending visitor." This speaks for itself.

In case you don't know, the Kwinana Oil Refinery is owned and operated by British Petroleum, and situated approximately 23 miles south of Perth, W.A., and one mile from the town of Kwinana. The town was named after a cargo ship which was wrecked in Cockburn Sound many years ago, and remains today a rusty hulk on the edge of the water. The name "Kwinana" is aboriginal for "pretty maiden." Unfortunately, the town does not live true to its name, and so I spent most week-ends in Perth, at an aunt's. Relatives have some uses!

Readers of John Steinbeck's novel, "Cannery Row," will remember Dora's establishment. Perth has its counterpart on a much larger scale in Roe Street, within easy reach of the city. This is a MUST for all visitors, the method of inspection depending on one's outlook. Although the profession is officially illegal, it is tolerated by the police, who have their headquarters in Roe Street. A similar situation, I believe, exists in Kalgoorlie.

Reference to Roe Street reminds me of Ruby. Although she worked at North Perth, Ruby was, and I suppose still is, one of Perth's chief widgees. Sunday afternoons used to find her at Scarborough, one of Perth's beautiful surf beaches. I say "used to," because police banned her from participating in the principal attraction after a fight with one of her girl friends which, unfortunately, I missed by half an hour. Swimming is only a minor sport at Scarborough, since the Police Boys' Club established an open-air rock 'n' roll pavilion as the principal attraction. Here anyone who wished could jive, and others could learn much by merely watching from the right places. The beach has thus become the Sunday headquarters of all right-thinking Perth bodgies and widgees. One felt out of place if not wearing black jeans and desert boots, preferably with a red or black shirt, while the fashionable girl

was seen in either very short shorts or tight (!) matadors, and a shirt or blouse in the brightest red or black, the outfit being completed by an exquisite contrasting pair of desert boots. I could soliloquise for hours on Scarborough, but space and civil laws forbid it.

Another interesting place is the town of Rockingham, about three miles north of Kwinana. This is the Victor Harbour of W.A. A fine beach and pleasant surroundings make it an ideal holiday spot, and far more worthy of the name "Kwinana." Perth beaches are, in fact, quite terrific, with surf or calm to meet one's tastes.

So far my armchair chat has described outside the Refinery. It would not be complete without reference to the inside. Of course, everyone knows what is processed—namely, oil. Now, this commodity comes in many forms, such as castor, olive, peppermint, the good (racing type), mid-night, and baby, but such names as Qatar, Kuwait, and Agha Jari Crudes may sound very much like types of Oriental pornography. They are, however, the varieties of crude oil used at Kwinana. From these a number of well known products, such as S.R.B., T.V.O., and A.T.K. are made. These need no description.

I worked in the Development Section, where many interesting theories on refinery practice were evolved. One of the best was what I call "The Hypothesis of the Sterilised Gamete." This hypothesis is based upon the following empirical data:

- (i) Sex hormones have been found in crude oil.
- (ii) Nearly all the children of the process staff at the Refinery are female.

Further experiments are proceeding. Copies of the Hypotheses (for intending visitors only, I'm afraid, in view of my limited stocks), with fully developed mathematical analysis and free rhythm table, are available at a modest price. However, it must be remembered that most of the initial development work is confidential, and cannot be discussed with complete libido.

On a serious note, Kwinana does offer very worth-while vacational employment for a third year or higher student. Return air fares are paid, and board subsidised. Working conditions are excellent, and interesting work given. A series of lectures is presented to acquaint the student with refinery operation.

This guide has unfortunately been very brief, as your editor feared banning of the magazine, but after all, "A moment's insight is sometimes worth a life's experience."

THROUGH OUR OWN

## ***LONDON BUYING OFFICE***

we are directly in touch with the World's Markets, and can guarantee

- ***The best selection***
- ***At the best prices***
- ***For the best time  
of the year***

of Autograph and Personal Greeting Cards and Christmas Stationery, also  
Gift Items, such as . . .

Playing Cards and Bridge Sets, Fountain Pens  
and Propelling Pencils of all makes, Mulga  
Goods, Walker's Loose Leaf Pocket Books,  
Inkstands, Latex Cushions, Book-ends, Loose  
Leaf Recipe Books

and

EVERYTHING FOR THE OFFICE AND STUDY

SEE OUR REMARKABLE VALUE IN  
OFFICE DESKS AND COMFY CHAIRS

# **Sands & McDougall**

PTY. LTD.

64 KING WILLIAM STREET - - - ADELAIDE

Telephone: LA 4641 (8 lines)

# INTER-FACULTY SPORT

*Inter-Faculty Sport has revived a little this year.*

## TUG-O'-WAR

Early in the first term we had the Annual Tug-o'-War across the Torrens, with the Medical students.

Our bronze heroes were quietly confident of repeating last year's thrashing. However, they became a little disheartened when the Meds. won the toss, and chose the highly fancied North bank.

The Meds. won the first pull, and the teams crossed banks. The Engineers easily won the second tug, and the teams crossed again. The all-important last try was about to begin. The Engineers slowly gained inch by inch, and almost had the heat won when the Meds., with better team-work, gradually regained the ascendancy, and alas, an Engineer was the first to hit the water.

It did not really matter, though, because this is the first time we can remember the Meds. winning the Tug-o'-War. (The referee was ducked, too, for further consolation.)



5—4—3—2—1—Zeer . . .

## RUGBY

Later in the year the Engineers challenged the Meds. at Rugby. Led by State captain Sandy Hone, and with other stalwarts in the team, we had high hopes of winning.

The play was very even throughout, and no one had scored at half-time. After the interval, however, the Meds. came a little to the fore, making better use of their chances. Both teams scored one try, only the Meds. converting. Both teams had one penalty shot, again only the Meds. converting, leaving the final scores at 8-3. Just wait until next year, Meds.!

## HOCKEY

In the second term the Engineers fielded a team of eleven hockey players against the Physiotherapists, also hockey players. This match we won about 4-2, in spite of the fact that the girls piled on 17 players in the second half.

To put the girls off their game, the Engineers wore pyjamas. Our centre forward, Vjih, tried to look helpless by playing in bare feet, but still managed to be our best player.



Take your foot off that ball!

## AUSSIE RULES

We tried to arrange a football match against the Meds., but it was found impossible to fit it in because of the Medical inter-year football.

A match may be arranged next year.

## DEBATE

The first debate against the Meds. for very many years was held in the second term. The Meds. tried to prove "That respectability is a bar to progress."

The debate proved to be a very even one, with our team of A. J. Dawson, T. L. Pascoe, and F. J. W. Symons going down by the odd point. Professor Blackburn was the adjudicator.

It was interesting to see the Medical men contradict themselves by winning, in spite of their greater respectability.



The staff at the Engineers' Ball



# CONTROL OF DAMPERS FOR VEHICLE SUSPENSION

By P. L. GOODALE.

Damping is defined as the phenomenon whereby vibratory motion encounters solid or fluid frictional resistance which dissipates a portion of the energy of vibration as heat. A free vibration would persist with undiminished amplitude if energy was not dissipated by a damper. Similarly, at resonance, the ultimate amplitude attained is dependent upon the degree of damping in the system, and would be infinite for zero damping. Thus it is at conditions of resonant excitation that the function of the damper is so important.

An independently sprung wheel possesses two modes of natural vibration. One, the lower frequency (1-2 cycle/sec) is the movement of the body mass relative to the unsprung mass on the main suspension spring. This motion is excited if a vehicle is driven at a certain speed (depending upon the rate of the suspension spring) over a road with a wavy profile. The motion of a car with ineffective shock absorbers driven over such a road is familiar to most of us. The higher natural mode of vibration (8-12 cycle/sec) is the movement of the unsprung mass relative to the ground on the pneumatic tyre, known as wheel hop, and which can lead to the wheel leaving the road. This movement is partially damped by the mechanical hysteresis damping in the rubber tyre. The conventional suspension damper, whilst it cannot damp this motion, is effective in keeping the tyre in contact with the road in that it controls the movement of the entire unsprung mass relative to the body (which can be considered fixed relative to ground at wheel hop frequency).

The introduction in recent years of the soft coil spring to improve road holding and passenger comfort has placed emphasis on the damper or shock absorber in maintaining amplitude and force transmission within reasonable limits during resonance. The combination of the soft coil or torsion bar spring and the hydraulic damper is an excellent one, but for optimum performance a suspension system whose characteristics could be varied to suit the road condition is desired.

Research of this nature is at present being carried out in the Mechanical Engineering Department, University of Adelaide. The general approach at present is to combine a controllable damper with a suitable nonlinear spring.

Let us first of all consider the various kinds of damping met in a mechanical system, and the way in which damping output might be controlled. Only the three most commonly met types of damping will be considered.

(a) Viscous or linear damping, in which the

damping force is proportional to velocity. Viscous damping occurs at low value of Reynold's Number (e.g., oil dashpots, hydraulic pump impellers).

(b) Turbulent air damping, in which the force approaches proportionality with (velocity)<sup>2</sup>. This occurs at high values of Reynold's Number (e.g., air dashpots, aircraft wing flutter). The current hydraulic suspension damper is of this type (flow through the orifice being turbulent). The force is prevented from increasing continually with velocity by automatic blow off valves which set an upper limit to the oil pressure. Furthermore, it is normal for rebound maximum pressure to be set at something like twice that for bump.

(c) Dry friction or coulomb damping, in which the force is approximately constant in magnitude, suddenly changing sign as the motion reverses, and giving a square wave form.

In cases of fluid damping, further factors affecting the damping force are fluid density and viscosity. In general, then:

Damping force =  $f$  (density, velocity, viscosity), and damping may be controlled by controlled variation of any three. Hence by fitting an hydraulic damper with variable orifices, the velocity could be varied, and thus the damping force. At first sight this would appear to be the only variable from a practical point of view, but with the advent of magnetic fluid has come a fluid whose viscosity can be made to vary over very wide limits.

Magnetic fluid consists of a mixture by weight of five parts of Iron E Carbonyl powder to one part of oil, Sheel Donax A1. The fluid has been found to be very abrasive, and a damper designed to use it should include as few moving parts as possible, and wide clearances where moving parts are involved. The fluid is very viscous, so fine orifices and clearances are not required. Under the influence of a magnetic field, the viscosity of the fluid increases greatly to the point of solidity.

It was decided that two dampers be designed and constructed, functionally different, but both utilising magnetic fluid to facilitate control.

Details of the two dampers constructed are as follows:

(A) This damper consisted primarily of two concentric cylinders capable of relative motion, whose surfaces were separated by a 0.030 ins. gap. This gap was filled with magnetic fluid. The inner cylinder contained a coil to produce the magnetic fluid in the region between the surfaces. The damping force was to be developed due to the viscous shear in the gap.



Opportunities for  
**ENGINEERS**  
 in the world of communication

**YOUNG ENGINEER CHECKING  
 PERFORMANCE ON A  
 TELEVISION CONTROL PANEL**

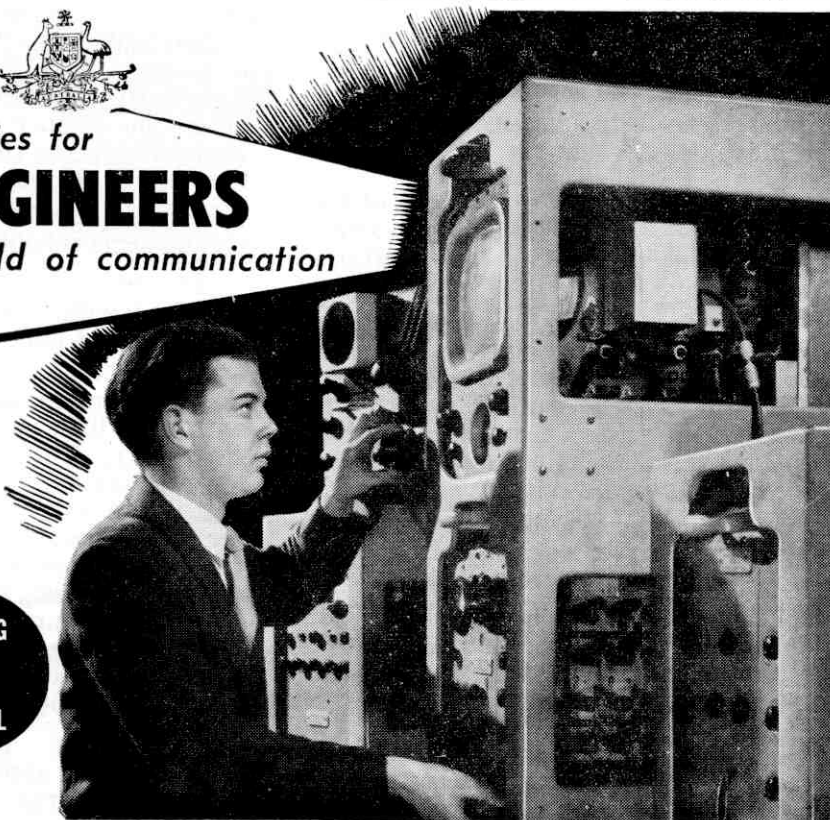

**POST OFFICE FACILITIES**

including telephone, telegraph, radio broadcasting and mail handling depend on the application of scientific principles to the highest degree, and offer qualified men a really worthwhile career — satisfying in every respect — developing and maintaining the national communication services. If you have educational qualifications giving full exemption from A.M.I.E.(Aust.) examinations, investigate this opportunity **NOW**.

Research and other special positions are open to men who possess a science degree in subjects appropriate to electronics or engineering.

**Commencing Salary from £1,043 to £1,403** per annum, according to qualifications, plus generous annual and sick leave conditions, superannuation, and other benefits. Opportunity is unlimited and promotion dependent only on your own ability and initiative.

**THIS IS YOUR OPPORTUNITY.** As the Nation grows so must communications develop.

**ACT NOW —**

Director-General,  
 Postmaster-General's Department,  
 Central Office, Treasury Gardens,  
 MELBOURNE, C.2.

Please forward one copy of the booklet "The Telecommunication Engineer in the Australian Post Office" to:—

NAME.....

ADDRESS.....

TELEPHONE NUMBER.....

PMGV8.FP.67

**BECOME A PROFESSIONAL OFFICER IN AUSTRALIA'S BIGGEST BUSINESS**

(B) This damper consisted of a vane moving in a chamber filled with magnetic fluid, which was positively displaced around the ends of the vane, and developed pressure providing the damping force.

In both dampers Silentbloc bushes were employed, to act both as bearings for the shaft and an oil seal.

The damper to be tested was mounted on the testing machine, the damper arm being driven by a Scotch yoke.

The forces generated by relative motion of the damper elements were then measured by a sensitive torquemeter, and displayed as work diagrams on a C.R.O.

Following a series of tests on the machine, it was concluded that the damping obtained from both magnetic fluid dampers was Coulomb, the work diagram being rectangular. The work diagram of a viscous damper is, of course, sinusoidal in outline, and a hydraulic damper varies between the two, depending upon the velocity. (See Fig.)

It was not, however, feasible to attempt to control the dampers to every bump in a road profile, because the time constant associated with the magnetic coil ( $T = l/r$ ) limited the rate of response to something like a second.

However, it was decided that some road tests could be carried out, and a comparison made with a hydraulic damper on the basis of force transmission (measured as body acceleration, since  $F = ma$ ). The damper to be tested was mounted on the Departmental two-wheel trailer, built for the purpose of damper research. A new mounting was made up for the nearside suspension to allow mounting either of the experimental dampers. The Armstrong hydraulic damper was left in position as part of the offside suspension. In this way each wheel could be run over the chosen bump in turn, and a comparison easily made.

The "bump" comprised 7/8 in. timber planks nailed to the roadway, with a ramp at one end.

Depending upon the direction of approach, a positive or negative step input could be applied at the wheel.

The acceleration of the body during the transient was measured with a Cambridge Accelerometer held on to the floor of the trailer as close as possible to the wheel running over the bump. As a further record, a potentiometer was mounted on the damper shaft to measure wheel movement relative to the trailer body; this information was gathered on a pen recorder.

Despite troubles with the recording instruments, some reliable information was obtained.

In each case the force transmission to the body was less with the experimental dampers than with the hydraulic damper, particularly over the negative bump.

Furthermore, optimum results were obtained with very little applied damping (approximately 1/3 max.). Too low values of damping reduced the acceleration, but amplitude control was lost, that is, the body persisted in a state of oscillation for a considerable time after the bump. High values of damping caused increased acceleration, due to harshness, and whilst body oscillation was almost dead beat, considerable flexing of the pneumatic tyre occurred. The trailer was given a run over an average rough road to check that the above value of damping was indeed a good average value.

The idea of applying automatic control to such units is not at present feasible, by reason of the time constant associated with the circuit, as mentioned previously, but the damping could be conveniently varied by means of a rheostat on the instrument panel.

Of course, such a system does not satisfy the requirements for controlled damping to suit the road profile, but it does give the intelligent driver a convenient method of varying his suspension characteristics to suit.

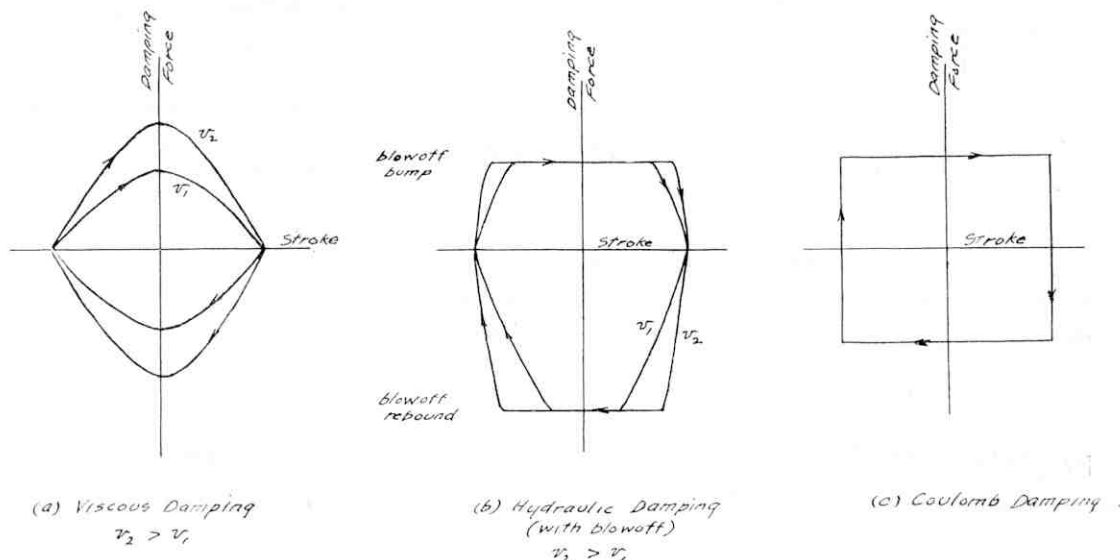

Ideal Work Diagrams

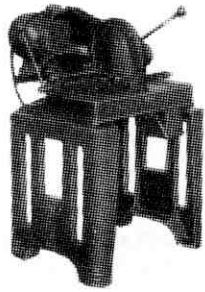

ABRASIVE CUT-OFF  
MACHINES



BENCH AND PEDESTAL  
GRINDERS

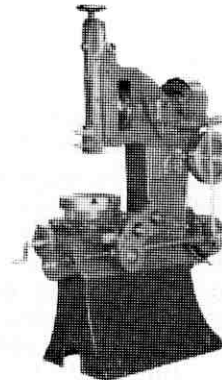

SLOTTING  
MACHINES

# McPherson's

Ltd.

102-130 WAYMOUTH STREET, ADELAIDE

Phone: LA 1961

MACHINERY MERCHANTS, TOOL MERCHANTS  
SUPPLIERS OF ENGINEERS' REQUISITES  
MANUFACTURERS OF PUMPS, BOLTS, NUTS, RIVETS  
MAKERS OF HIGH GRADE MACHINE TOOLS

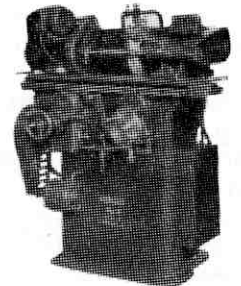

SEMI-UNIVERSAL  
GRINDERS

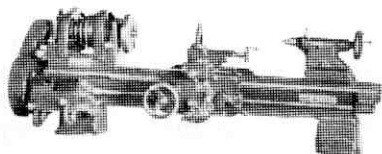

LATHES

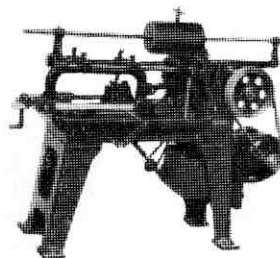

HACKSAW  
MACHINES

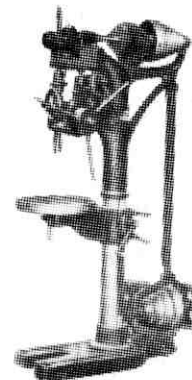

DRILLING  
MACHINES



# FRUSTRATION

By K. R. WELLER.

## *The decline and fall of Throgmorton.*

Frustration seems to be a word that is being used universally to describe the peculiar mental condition that most engineers fall into with increasing frequency as the year draws towards its inevitable conclusion. The disease, which it undoubtedly is, generally appears in one of two forms, equally devastating, both of which will be discussed separately.

The first, and possibly less deadly brand of frustration is that brought on by conflict, or lack of conflict, with members of the opposite sex. This may or may not be the fault of the engineer. In any case, if large quantities of female students (Arts or otherwise) suddenly saw the light, and decided to study Engineering (or engineers), the invalid rate would approach zero (or infinity) very rapidly.

The second is the more common and virile type of frustration, which makes the engineer impervious to all types of spiritual enlightenment and extra-curricular activities, and the despair of all righteous, deep-thinking students who are conscious of Man's Higher Destiny, and the pleasures of treading the primrose path.

The latest victim of this dread disease is none other than our hero, that truly great personality, X. Y. Z. Throgmorton. (Students may come and students may go, but Throgmorton goes on for ever.) No longer can he be seen haunting the parallel bars, drinking his daily dozen; or at the refectory, ogling the "gens feminis" from the A.T.C. Let us follow him to his home at "Bowden-on-the-Hill," where we may study his innermost thoughts at our leisure. . . .

After a stupendous meal, Throg moves into his inner sanctum as fast as a bloated stomach will allow him. We follow.

He sits down amid a pile of text books, notes, paper, drawing instruments, etc., and begins to work. (Revelation—"what a falling-off is there.") The hours pass. . . . Eventually bed is indicated. At present bed is X.Y.Z.'s arch enemy—a complete time-waster! However, his inner man warns him that a few hours' sleep are essential. . . .

"To sleep: perchance to dream: ay, there's the rub." . . .

He tosses and turns. Visions of deflected neutral axes of D.C. armatures, against a background of complicated phase diagrams, float before his mind's eye.

"Canst thou, O partial sleep, give thy repose  
To the wet sea-boy in an hour so rude,  
And in the calmest and stillest night,  
With all appliances and means to boot,  
Deny it to an engineer?"

Shakespeare was right, as usual. It could.

Gradually a calmer mood overtakes him. Archimedes' Principle still holds good—a comforting thought. Sleep descends. . . .

Brrrrring . . . Eight o'clock, Throg, old man, eight o'clock. Throg stirs and grunts as consciousness returns. Eight o'clock. Throg is out of bed, under the shower, dressed, breakfasted, and half-way to the 'Varsity on his venerable "treadly" before one can say "Strength of Materials."

He arrives at the lecture, flops into his seat, and automatically prepares for the immediate future. He is still half asleep. The lecture proceeds; he is almost asleep again.

Suddenly a thought strikes him! Fifty million curses! He has left his tee-square home. Throg is wide AWAKE now! The day has begun.

Many days pass thus, and Throg no longer seems human; he becomes a mere automaton, driven by a force which is inversely proportional to the number of days to the exams.

In other words, "frustration" is a mental attitude brought about by pre-occupation with study. It is characterised by a vacant preoccupied look, stooped shoulders, and a disposition to speak to nobody unless it is to enquire about some relevant technical matter.

Consider what sort of person Throgmorton must be after graduation.

To be a successful engineer, Throg must be a leader of men, capable of quick, accurate decisions. He is expected, in an emergency, to produce the goods out of almost nothing. Employers hope to turn him into a top-class executive.

Contrast this dazzling picture of X. Yoseff Z. Throgmorton, F.B.E., Company Director, with bewildered, frustrated x.y.z.—undergraduate. Is his University course preparing him for his future career of service to the community? Is it meant to? What part do extra-curricula activities play? It is fairly obvious that a student is not going to develop the necessary qualities by studying facts, formulae, and design procedure alone.

The years spent at the University are some of the most formative years of a student's life, and it is vitally important that he should leave with a sufficiently broad outlook to be able to absorb and accommodate himself to radically different ideas and methods of thinking.

The vital question is whether the course does promote this outlook and those character traits desirable in a practising engineer. If it does not do this, does it allow sufficient time for a student to engage in activities outside the engineering building which will enable him to gain a more balanced view of life, its purposes and meaning?

# ELECTRICAL RESEARCH

*The tasks he undertakes,  
Is numb'ring sands, and drinking oceans dry.*

## DYNAMIC A.C. NETWORK ANALYSER

This is a simulator using electronic and electromechanical techniques, by means of which a flexible model of electric power generation and distribution systems may be set up for the purpose of designing and operating such power systems.

Owing to the complexity of present-day power systems, it is too laborious to attempt to calculate performance; accordingly, some form of time and labour-saving computer is considered essential by power authorities, who favour the electrical model approach because of its simplicity and similarity to the actual case, enabling engineers to operate (and obtain direct measurements from) the device as they would the actual system.

The Analyser being at present constructed in the Electrical Engineering Department is of original design, and allows problems to be set up

and solved automatically. This is made possible by the particular method of synchronous machine representation, and in this respect differs from other existing network analysers.

In addition to power system studies in general, the Analyser can be employed to solve other engineering problems which can be reduced to suitable sets of simultaneous equations. When used in conjunction with the Electrical Engineering Department general purpose analogue computer, the flexibility of both instruments can be increased.

Construction of the Dynamic Analyser has been made possible by the generous provision of a considerable sum of money by the Electricity Trust of South Australia.

S. KANEFF.

## FREQUENCY COMPRESSION OF THE SPEECH BAND.

Workers engaged on research under the direction of Professor E. O. Willoughby: R. E. Bogner, Roger Smith.

The object of this project is to reduce the band-width necessary for the successful transmission of speech of telephone quality. At present the band-width required, including an allowance for channel spacing, is 4 Kc/s; by frequency division we hope to reduce this to 2 Kc/s, and then, possibly, by further division, to 1 Kc/s.

Although on normal trunk lines this saving—two channels in the space of one—appears small when we take into account the increase in terminal equipment, it is of extreme importance on overseas routes, where the cost of laying submarine cable and underwater repeater stations far outweighs the cost of terminal equipment.

In order to understand the mechanism of frequency division, it is necessary to have a working knowledge of the nature of speech. Speech, which at first sight appears to have a very complex wave-form, is greatly simplified if we consider the method of production. Basically, one speaks by modulating the flow of air which passes through the windpipe, vocal chords, and the three cavities of the throat, nose, and mouth. Vocal chord modulation, produced by vibration of the vocal chords, results in audio waves of a sawtooth shape, and fundamental frequency varying between about 75 c/s and 500 c/s. Due to the wave shape, there is a large number of harmonics present. These harmonics are passed to the cavities, which may be likened to resonant

circuits, and which tend to suppress some harmonics and, thus by comparison, accentuate the other, the exact shape of the output wave-form depending on the shape and sizes of the cavities, which, of course, are varying with different sounds. Hence the speech wave-form will at any instant contain three predominant frequencies, together with other reduced harmonics.

Speech is further complicated by fricatives which produce the s, f, etc., sounds, but these also contain the three predominant frequencies, or formants.

The speech input signal is passed to a filter bank, which separates the signal into three channels, each containing one formant. Each channel is now fed to regenerative frequency dividers, which reduce the band-width. The separation into three channels is necessary to prevent intermodulation products being formed between the formants, thereby producing distortion. The intermodulation products formed in each channel are small compared with the formant frequencies. The channels are now combined, transmitted, filtered into three channels at the receive end, frequency multiplied, and recombined to give intelligible speech.

The equipment built to date successfully divides the band-width by a factor of two, except that the channels are not combined for transmission. There is no noticeable difference, except a slight increase in noise level, between the divided signal and a straight-through signal.

The next step is to combine the channels for transmission, and then to experiment with a "divide by four" system.



# William Adams & Company Limited

157 WAYMOUTH STREET, ADELAIDE - - - LA4221 (12 lines)

*Proudly Represent:*

**ALFRED J. AMSLER & CO.,**  
Schaffhouse, Switzerland.

Testing Machines for testing materials in Tension, Fatigue, Impact, Brinell, Creep, Torsion, Shear, Bending; Hydraulic Jacks.

**ALLEY & MACLELLAN (POLMADIE) LIMITED,**  
Glasgow, Scotland.

Air Compressors, capacity 50-5000 c.f.m., pressures to 120 P.S.I.

**BINNS & BERRY BROTHERS (HALIFAX) LTD.,**

Ovenden, Halifax, England.

Lathes, 7½ in., 8½ in., 9½ in., 11½ centres, for light and heavy duty.

**BRITISH INDICATORS LIMITED (John Bull),**

St. Albans, Herts., England.

Dial Gauges, Test Sets., etc.

**CRAVEN BROTHERS (MANCHESTER) LIMITED,**

Reddish, Stockport, England.

High Speed and Heavy Duty Lathes up to 100 in. Centres.

Horizontal Boring, Drilling and Milling Machines.

Vertical Boring and Turning Machines. Heavy duty machines up to 50 in. dia. table.

Planing Machines, Spiral Drive, Heavy duty.

Roll Turning Lathes.

Roll Grinding Machines.

Roll Tenon and Wobbler End Milling Machines.

Slot Milling and Key Seating Machines.

Gear Hobbing Machines.

Bevel Gear Generating Machines.

Worm Thread Grinding Machines.

Railway Axle Journal Lathes.

Railway Wheel Lathes.

Railway Crankpin Quartering Machines.

Large Crankshaft Lathes.

Machines to special requirements.

**CROSSLEY BROTHERS LTD.,**

Openshaw, Manchester, England.

2 and 4 cycle Diesel Engines for Marine, Stationary and Locomotive purposes in powers from 6 to 2500 h.p.

**CROSSLEY-PREMIER ENGINES LTD.,**

Sandiacre, Nr. Nottingham, England.

Oil Engines with Vis-a-Vis and horizontal cylinders for industrial application in powers from 375-3000 h.p.

**B. & F. CARTER & CO., LTD.,**

Bolton, Lancs., England.

Brading Machines.

Cable-making Machinery.

Wire Tinning Plant.

Revolution Counters.

Speed Indicators.

**DENFORDS ENGINEERING CO. LTD. (Boxford),**

Wheatley, Nr. Halifax, England.

9-in. Swing Precision Lathes.

Dumpy Stands.

Universal Stands.

Comparator Gauges.

**THOS. FIRTH & JOHN BROWN LIMITED,**

Sheffield, England.

Diamond Hardness and Brinell

Hardness Testing Machines—bench type.

**GRESHAM & CRAVEN LIMITED**

Manchester, England.

Ejectors for Steam, Air and Water.

Injectors for boiler feed water—stationary and locomotive.

**GREENWOOD & BATLEY LIMITED,**

Leeds, England.

Mining Locomotives, battery and

Diesel—electric-operated.

Electric Platform Trucks and Fork

Lifts.

Also:

Hot and Cold Forging Machines.

Upsetting Machines. Thread Rolling Machines.

Screw Presses.

**HILGER & WATTS LTD.,**

London, England.

Optical Projectors for Shop, Tool-room and Laboratory installations in floor and bench types.

Block Levels and Clinometers.

Angle Dekkor for Optical Angle

Measurement.

Gauge Pairing Interferometers.

Optical Flats.

Angle Gauges.

Dividing Engines.

Precision Scales.

Measuring Machines—vertical and horizontal.

Autocollimators.

Optical Alignment Equipment.

Micrometer Water Levels.

Brinell, Engineers' and Jib Borer Microscopes.

Spherometers.

Ship's Inclinometers.

Machine Tool Scale Projectors.

**LESLIE HARTRIDGE LTD.**

London, England.

Diesel Fuel Pump and Injector

Test Equipment, consisting of Test Benches, Nozzle Reconditioners, Injector Testers, Puller Presses, Microscopes, Pump Vices, for all types of diesel fuel pumps and injectors.

**A. A. JONES & SHIPMAN LIMITED,**  
Leicester, England.

Hydraulic and Mechanically-operated Precision and Production Grinding Machines.

**JAMES NEILL & CO. (SHEFFIELD) LTD. (Eclipse),**

Sheffield, England.

Magnetic Equipment.

Magnetic Holders.

Magnetic Floaters.

Alcomax Chucks and Accessories.

Permanent Magnets.

Demagnetisers.

**C. A. PARSONS & CO. LIMITED,**  
Heaton Works, Newcastle-upon-Tyne.  
Turbo-Alternator.

**SUNDSTRAND INTERNATIONAL CORPORATION,**

Rockford, Illinois, U.S.A.

and

**SUNDSTRAND INTERNATIONAL EUROPE,**

Courbevoie, Seine, France.

Production Milling Machines, simple, duplex, triplex, and special—3-100 h.p.

Production Lathes—Automatic Cycling, Multi and Single Tool Types, to 75 h.p.

Automation Machinery.

**AMERICAN BROACH & MACHINE CO. (a Division of Sundstrand International Corporation),**

Ann Arbor, Michigan, U.S.A.

Vertical and Horizontal Hydraulic

Broaching Machines.

Single and Dual Ram Surface

Broaching Machines.

Broaching Tools and Pullers, etc.

**TAYLOR, TAYLOR & HOBSON LIMITED,**

Leicester, England.

'Talymin' Voltage Regulated Comparators.

'Talysurf' Surface Finish Instrument.

'Talyden' Comparator Microscopes for Screws, Threads, etc.

200 in. Projectors—3 in. and 6 in. Fields.

Alignment Telescopes.

Continuous Strip and Sheet Gauges.



# S.C.I.I.A.E.S.

*The Society for the Confining of Immoral  
Impulses Among Engineering Students.*

We now have a very active branch of the S.C.I.I.A.E.S. in Adelaide, and members and intending members may find this short history of the Society interesting.

On April 24, 1956, a group of 50 Melbourne Engineers, appalled by the blatant immorality to be seen in their University, just as it can be seen in ours, formed the first branch of the Society. Otago University followed suit, and then, on May 30th, 1957, the Adelaide branch was formed, and on the same day held the now famous Ceremony of the Stone.

A general meeting held shortly after this noble occasion saw an enthusiastic gathering of the righteous, at which plans for the Annual Breakfast were started, and many good suggestions for Procession Day proposed. Subscriptions were also collected. The Melbourne branch receives a grant from their S.R.C., but, unfortunately, although the Adelaide branch has S.R.C. affiliation, it has been refused a grant, so a nominal fee of 2/- yearly must be charged members to cover the administration costs of the Society.

Members of the Adelaide branch will in due course receive Federal Registration cards, and may be able to buy lapel badges next year to demonstrate their purity for all to see.

The Prospectus for the Society is as follows:

The Society shall be concerned with the causes, effects, and nature of immoral impulses, and, where applicable, with special reference to engineering students.

The Society shall also be concerned with ways of controlling immoral impulses, which is included in the general subject of self-control or self-discipline.

The Society shall confer honorary degrees on such persons who, through their actions and writings, aid the Society in its aims.

Functions of the Society should include the publication of literature, the presentation of lectures and debates, and the investigation and acquisition of facts relevant to the Society, which should include an Annual Dinner and Breakfast, Informal Smoke Nights, and possibly dances.

The first degree awarded was to Dr. Woods, who was, by decision of the Executive, admitted to the rank and privileges of the degree of Doctor of Social Super-propitiousness (honour's causa) at the A.U.E.S. Dinner.

---

## CIVIL I DRAWING

Oh, no, sir! I fear that you have the proverbial male bovine quadruped by its bony protuberances.

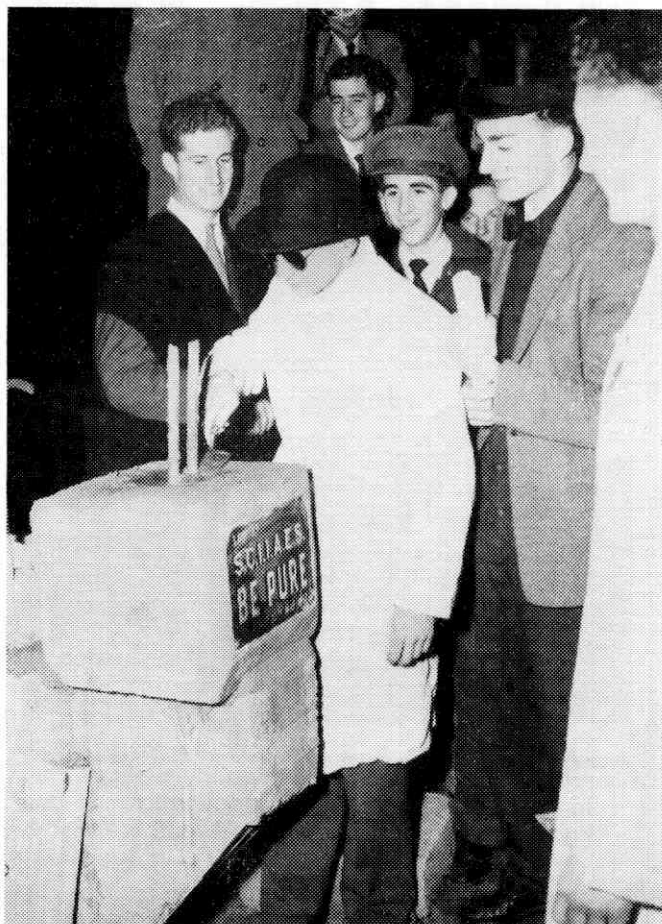

**The Famous Stone**

All people who are desirous of joining the S.C.I.I.A.E.S., and upholding its motto of "BE PURE," are urged to make contact with a committee member immediately, and communicate their desire to him.

Committee members for 1957 are:

President: J. F. Bateup.

Vice-Presidents: F. J. W. Symons, R. W. Hercus.

Secretary: M. J. Blaskett.

Treasurer: A. J. McLean.

Committee Members: L. Davey, A. J. Dawson, P. Day, C. Hastwell, G. Marriott, A. Read, D. Rudd.

---

Just what is this necking process which is sometimes accompanied by the formation of twins that Mr. Denholm has mentioned?





# FORD ONE YEAR TRAINING PLAN

In 1953 the Ford Motor Company inaugurated a One Year Training Plan providing for a 12 months' training programme for selected graduates from Universities and Technical Colleges throughout Australia. The first programme commenced in February, 1953, with 10 participants, and was repeated annually with that number until 1956, when the number was increased to 15.

## **Nature of Training**

The Plan provides for twelve months' broad training covering all sections of the Company. It aims—

- (a) To give trainees a practical insight into basic problems of management in industry and how they are solved.
- (b) To impart an understanding of the nature and purpose of business organisation and the principles of business management.
- (c) To assist development of the personal qualities necessary to participation in industry at senior level.

In substance, it is designed to relate theoretical knowledge to practical operations and to facilitate the ultimate application of that knowledge in the managerial field.

The training is based on a variety of practical work assignments, supported by formal training in such fields as scientific management, methods engineering, budgetary control, report writing, public speaking, and general personal development.

Choice of work assignments, which may cover several divisions of the Company, is primarily influenced by the trainee's inclinations and academic training.

## **Subsequent Appointment**

At the end of the training period trainees, subject to satisfactory performance, may be offered appointment to a position in the choice of which their own inclinations and demonstrated aptitudes will have been important factors.

Thereafter their progress with the Company will be determined solely by their demon-

strated capacity to do the job in hand. Trainees remain free to accept or reject any offer of employment.

## **Salary**

Salary during the training period is liberal.

## **What is Required**

Minimum academic qualification is the successful completion of examinations required for a degree or diploma.

Personal qualities required include the ambition to rise to leadership status in industry; energy; good personality; high character; and potentialities for leadership.

## **The Company's Operations**

Head Office of the Ford Motor Company and the main centre of manufacturing operations is at Geelong, Victoria, with branches at Sydney, Brisbane, Adelaide, Fremantle, and Ballarat. Training takes place at Geelong.

Operations cover all aspects of business activity, thus ensuring opportunities for all types of trained minds. In its selection for training programmes the Company seeks to strike an appropriate balance between technical and non-technical graduates.

## **Ex-Trainee Appointments**

Positions occupied by ex-trainees all offer excellent opportunities for advancement, and have, in fact, already led to many appointments of responsible supervisory status, including departmental managers, sales and service representatives, and a variety of important positions in the manufacturing and other divisions. Faculties represented are Engineering Law, Commerce, Science, Arts, Economics, Agriculture.

## **Further Information**

Further information may be obtained at any time from the Office of Industrial Relations, Ford Motor Company, Geelong, or from University Appointments Board and Technical Colleges.

## ARE YOU EDUCATED?

Why do so many engineering students fail? Are the courses too difficult? What is the object of an engineering course? These are questions which concern all engineering students.

It is the purpose of a student Education Sub-committee to look for the answers to these and similar questions.

Education Sub-committees have had spasmodic existences in Adelaide, although they flourish interstate. One such committee was largely responsible for the introduction of the five-year course in this University. However, since then, little has been done.

Many members of the A.U.E.S. Committee feel that an Education Sub-committee should be formed again. The object of such a committee would be:

- 1.—To decide, in conjunction with the staff, what the objects of an engineering course are.
- 2.—To examine the courses in the light of this decision; and
- 3.—To recommend improvements to the Faculty.

Broad topics for discussion could include:

- (1) Overlap of subject matter.
- (2) The relation of one subject with another.
- (3) The need for non-technical training, e.g., some arts subjects.
- (4) Preferred lecturing techniques.
- (5) Practical work.
- (6) Report writing. And so on.

It should be clear, then, that the aim of the committee would not be to find an easier course

for the student, but rather to find means by which the student's efforts can be made more effective.

As students, we have a right to express our views on what we are taught, and how we are taught.

If, on reading this article, you would like to become a member of an Education Sub-committee, then give your name to the committee. Willing workers are wanted.



## HARDING & HALDEN PTY. LTD.

61 FLINDERS STREET, ADELAIDE — W 5748

(Also all mainland capitals and N.Z.)

**FOR:** The complete Drawing Office, Equipment, Materials and Plan, Printing Service.

Consult us for your needs in our field, and receive the benefit of the experience of over thirty years of service to the professional Engineer and Drawing Office.

For drawing work in the preparation of Theses consult us in the choice of materials and technique to achieve the most favourable results in Plan Printing.

PAPERS (TRACING, CARTRIDGE, GRAPH, LOGARITHMIC), SLIDE-RULES, INSTRUMENTS, BOARDS, TEE SQUARES, COLOURS, INKS, BRUSHES.

# *Precision*

TOOLING

PRESS TOOLS

GAUGES

JIGS and FIXTURES

**Comprehensive Service and Experience with the Leading Industries of the Commonwealth, combined with modern plant and methods, ensures Precision Results . . . We will give you a Quotation without obligation.**

*Plant Units include . . .*

‘SOCIETE GENEVOISE’ Hydroptic 6

JIG BORER which is installed in a pressurised and dustproof room

# **SATOO L**

## **S.A. TOOL & GAUGE LIMITED**

**624 PORT ROAD, BEVERLEY, SOUTH AUSTRALIA -- JL 5286**

# HIGH PRECISION MACHINE TOOLS

By R. B. SMITH.

One of the main factors on which efficiency in the workshop and factory depends is orderly arrangement of machinery. This is particularly so for factories doing repetition work requiring several operations on different machines, but is still very important in the case of those which specialise in "1-off" jobs, such as S.A. Tool and Gauge, Limited.

The workshop of this particular concern is as neat and orderly as a chessboard before battle is joined. Each row of machines consists of a particular type. For example, the first row is devoted to planers and shapers. These are followed by a row of lathes, and then surface grinders, milling machines, metal bandsaws, and presses.

In one corner of the factory is situated the heat treatment plant, the main component of which is a gas-fired cyaniding furnace. This furnace, of course, has all the necessary equipment for efficient fume removal. The plant also consists of a couple of small electric furnaces and an oil bath, and also a Rockwell hardness tester.

Here are some of the interesting details concerning the machine tools already mentioned. Firstly, all the chucks on the surface grinders are magnetic. Secondly, the metal bandsaws are provided with a very ingenious butt welding apparatus for quick joining of saw ends. Also, to prevent fracture of the brittle weld due to bending, annealing apparatus is supplied. One of the specialised milling machines used is the profile milling machine, which produces an irregular form by reproducing the shape of a master template or model. For ordinary profiling, a fully rounded ball-shaped cutter with spiral flutes is used, which is held in a vertical milling spindle which, in turn, is connected to the vertical tracing spindle. The type of cut may be adjusted so that rough cuts are taken first, and then successively finer cuts. After each cut the table moves horizontally (an amount according to the size of cut), and perpendicular to the cutter traverse, and is then ready for the next cut. Quite a fine finish is obtainable with this machine. It is particularly suitable for producing asymmetrical dies and those used in the automobile industry for car bodies.

One of the largest machine tools in the factory is a planing machine (i.e., the work moves against the stationary tool, as distinct from a shaper, in which the tool traverses the stationary work). This particular planer is large enough to accommodate work 12 feet long and 3 feet wide.

An expensive machine tool, not in the general run of equipment in a factory, is the very specialised thread grinder. The thread grinder of S.A. Tool and Gauge was made by Societe Genevoise,

Geneva, Switzerland. It employs a multi-edged type grinding wheel about 1 inch wide, the shape of the thread being cut on the wheel. This is a severe limitation, of course, as a different wheel is needed for each thread size. However, this method has no equal where speed and accuracy are required. If the length of the thread is less than the width of the wheel, as is more often the case, it is possible to complete the grinding in practically one work revolution. If the thread is longer than the wheel width, the wheel may be shifted axially one or more times for grinding the remaining part. Otherwise a multi-edged tapered wheel may be fed axially along the work. The maximum recommended diameter for this machine is two inches.

All the machines mentioned above, however, pale into insignificance when compared with the magnificent jig borer, also made by Societe Genevoise. It is only rarely that one has an opportunity of examining a machine such as this, as there are so few about. There are two in South Australia, I believe. At first sight it is a mass of machinery of bewildering complexity. Actually, its operation is quite simple, as it is so arranged that either the part to be bored or the boring spindles (or both work and spindles) can be adjusted to accurately locate the holes at given centre-to-centre distances without preliminary measurements or laying out. One of the accessories for this machine is a rotary table for precision circular indexing. The table may be tilted for drilling holes at an angle. A rapid traversing hand wheel is used for approximate adjustment, and a smaller slow motion hand wheel for the exact position.

The measuring system used is a standard scale with a projection-type translucent screen, instead of the usual micrometer microscope, graduated to 0.0001 inch.

The table traversing mechanism is operated by a hydraulic cylinder. The table is mounted on rollers, and the fine feed for setting is operated by push buttons from three stations around the machine. The vertical spindle is mounted on a carriage which is traversed through a lead screw by an electric motor, and has fine hand-feed for setting. This jig-borer will accept work 40 in. x 28 in. x 26 in. high, and hence will machine very large complex jigs and dies with great accuracy.

Finally, in a factory which produces high precision work such as jigs and dies, checking the final product is essential. This is carried out in the measuring room, where all measurements are carefully checked against the appropriate drawings.



# SHAME ON ENGINEERS

By G. MEIJA.

"Oh! So you are an engineer?" said the beautiful blonde, looking very disinterested. "That's nice. I did not suspect—well, yes—your hands are clean, that's it."

"Yes, you see," I hopefully explained, "I used a special compound of my own tonight. It consists of sand, steel shavings, sodium hydroxide, and . . ."

"That's nice," said the beautiful blonde, looking more disinterested than before, and raising one of her beautiful eyebrows, she changed the subject.

"Do you know any Med. students?"

"No, not really. Charles Slaughterhound is the only one I have come in contact with—fixed his bomb up for him: made it into a real pepped-up hot buggy. It was one of those old 1932 Daimlers you can find at the wrecker's. We planed one-thirty-second off the head, bored and sand-papered the ports, put CAT D4 valves in her, and . . ."

"Really. That is very nice, I'm sure," said the beautiful blonde, looking grossly disinterested, and then, raising the other beautiful eyebrow, she changed the subject again. "But what about this gentleman?"

"Why?" I must have looked as if confronted by a strain curve.

"Come, come. Surely he is not that bad!" And this time she seemed slightly interested.

"Oh, you mean Charley. Well—he is just a typical Med. square."

"Is he really? They are all such dears, you know! Is he handsome?"

"Who. Oh, you mean Charley. Well—hard to say . . ."

"But it does not matter, of course. All Med. students are charming and interesting. Now, don't you contradict me! They all are wonderful dancers, and so interesting to talk to—full of naughty little stories. Do you know what interests Mr. Slaughterhound most?"

"Women!"

Then I realised that I had touched a series excited subject, with the conjugative points being rather sharp. I mean the fairer sex.

"But, of course, they always show their interest in a charming manner. They are quite the opposite to the Engineers, you know. For example, the Med. students are interested in the better things of life. There is music one can chat about—I love music—Wagner I think is nice, don't you? And poetry, and—food. . . They have such charming tastes, and then they are so clever about books, you know. Books, I think, are wonderful things—so educational, improve the mind . . ."

I was watching the rhythmical expansion and contraction of her—chest; rather a damped oscillatory motion. As she was speaking her lips looked full and warm, I noticed, but it was hard

to say whether the upper line would be a sine curve or not. I decided that it must, for the sake of being perfect. Yes, as the Prof. said, a good chassis is an important factor; it has to be strong, but not bulky or weighty—and, of course, the standard fittings have to be in the right places.

". . . They don't really mean that, of course. One can never talk with Engineers so freely. They are always full of that repulsive mathematics. I just hate mathematics—I can't understand how people can be interested in logic, it's so boring! Then socially, the Med. students are much more important. 'Doctor' sounds nice, don't you think? . . ."

I nodded. Yes, "nice" was the word for it, and logic could not always be used. The simple conclusion was that headlights and simple harmonic motion should not be dissociated. Then the question crossed my mind: Why? The engineer in me was seeking to investigate.

". . . Med. students are always so theoretically naughty, don't you think? They . . ."

"Is that so?"

An idea flashed through my mind at a frequency of 1000 Kc/s.

"That is where we engineers differ, you know."

She looked at me, her long eyelashes vibrating, surprised, slightly interested.

"Really!" she said.

"Well, yes. It is true that we engineers are mad people, possessed by some mathematical or electronic formula, but we are mainly practical realists. We always like to realise our theories, our mad dreams . . ."

"Really?" Her eyebrows were raised to a great height.

"So, you see," I continued, wondering whether I was differentiating correctly, "instead of boring you with theories, I would like to show you around the engineering buildings, to give you a better and fairer understanding of things—and engineers."

"Mhmm," she said, and gave me one of those 45 degree side-stabbing glances. I decided that she was becoming very interested, and that the theorem that resistance increases with heat had one exception.

"Mother, forgive me. I am doing this for the good name of the engineers," was my last rational thought as I cautiously took her arm.

. . . I decided that she had plenty of calories to spare, and where there are calories there is heat; and where there is heat there is energy; and where there is energy there is potentiality; where there is potentiality there is probability; where there is probability there is possibility; and where there is possibility—there is an engineer, so . . .

# WHAT DO YOU WANT FROM YOUR CAREER?



OPPORTUNITY . . .

RECOGNITION . . .

VARIETY . . . ?

## A career in the Steel Industry offers all these!

With its £100 million expansion programme in full swing, the Steel Industry can offer young men unrivalled opportunities.

Graduates in Engineering, Metallurgy or Economics should not fail to enquire about cadetships available in the Steel Industry. These provide thorough training and planned development in preparation for the many positions of responsibility for which such qualified men are selected.

The Steel Industry is the Nation's largest private enterprise and its successful functioning calls for trained young men willing and able to play their part in supervision and management. With extensive steel plants, large construction projects, an Australia-wide Sales organisation and the largest private shipping fleet on the coast, the B.H.P. Group can provide a challenging, well paid career for you.

Call in to discuss your future,  
or write to —

THE BROKEN HILL  
PROPRIETARY CO. LTD.  
28 Franklin Street  
Adelaide. Tel.: LA 1503

**BHP GROUP**  
SERVING AUSTRALIA WITH STEEL